

89260-062

6' PROTECTOR XSTREAM LABORATORY HOOD

NOMINAL WIDTH	TOTAL EXHAUST CFM & STATIC PRESSURE	100 FPM S.P.	80 FPM S.P.	60 FPM S.P.
6 FEET	⊙ 18" SASH OPENING (62.5% OPEN)	720 0.16"	575 0.10"	430 0.06"
6 FEET	⊙ 28" SASH OPENING (100% OPEN)	1150 0.41"	920 0.26"	690 0.15"

NOTE: SASH STOP INCLUDED AT 18" POSITION.

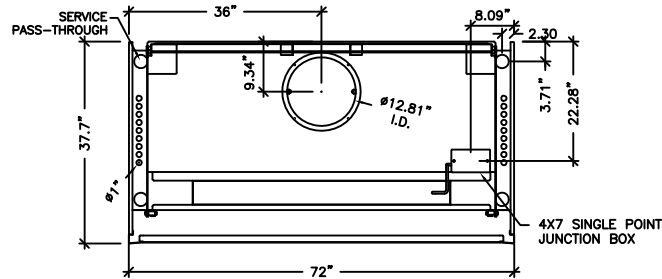

TOP VIEW

SCALE: 1/2" = 1'-0"

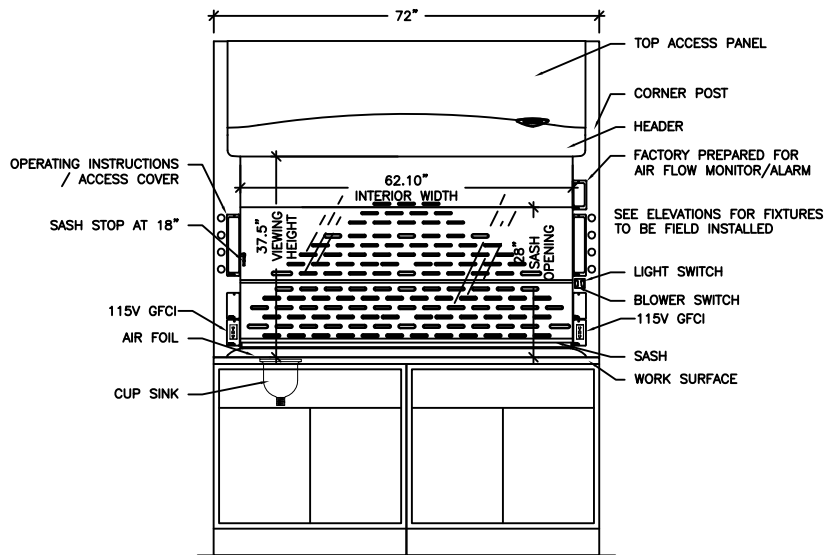

FRONT VIEW

SCALE: 1/2" = 1'-0"

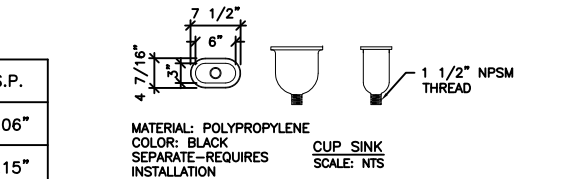

MATERIAL: POLYPROPYLENE
COLOR: BLACK
SEPARATE-REQUIRES
INSTALLATION

CUP SINK
SCALE: NTS

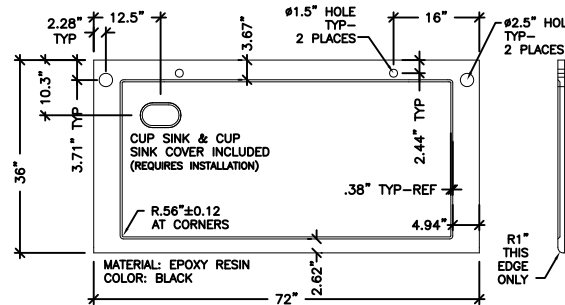

89260-078
WORKSURFACE

SCALE: 1/2" = 1'-0"

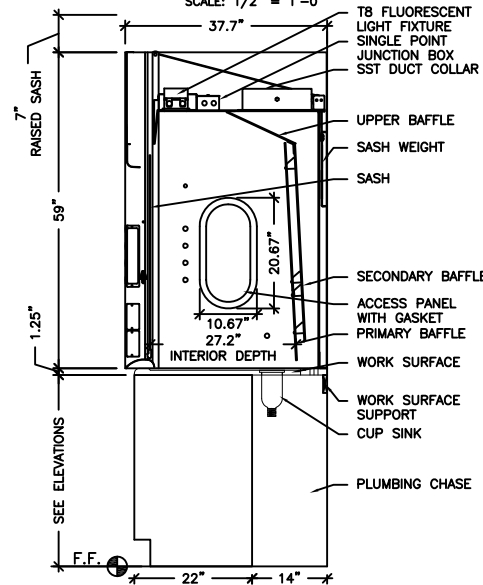

SIDE VIEW

SCALE: 1/2" = 1'-0"

GENERAL DESCRIPTIONS

EXTERIOR SUPERSTRUCTURE

DOUBLE WALL CONSTRUCTION
18 GAUGE COLD ROLLED STEEL
COLOR: GLACIER WHITE

INTERIOR SUPERSTRUCTURE

GALVANIZED STEEL (STANDARD)

LEFT / RIGHT FACIA

POWDER COATED STEEL
COLOR: GLACIER WHITE

LINER MATERIAL

MOLDED COMPOSITE SHEET

SIDE PANELS

BOTH SIDES - REMOVABLE
COLOR: GLACIER WHITE

ELECTRICAL FIXTURES

FLUORESCENT LIGHT AND TUBES W/ SWITCH
(2) 115V / 60HZ / 20A GFCI DUPLEXES
ADDITIONAL ELECTRICAL FIXTURES ORDERED SEPARATELY
TO BE INSTALLED AND WIRED BY OTHER

WIRING

FUME HOOD WIRED AT FACTORY
ELECTRICAL SERVICE CONNECTION MADE INSIDE 4X7
JUNCTION BOX
100-115 V, 50/60 HZ
OVERLOAD RELAY THERMAL UNIT (P-HEATER) NOT
PROVIDED WITH HOOD

SASH

VERTICAL TRAVEL
TEMPERED SAFETY GLASS
COUNTER WEIGHTED AND BALANCED
PULLEY SYSTEM
SASH STOP ⊙ 18"

BAFFLES

MOLDED COMPOSITE SHEET

INTERIOR ACCESS PANELS

RIGHT AND LEFT SIDES - GASKET PROVIDED

CORNER POST WITH ACCESS COVERS

RIGHT AND LEFT SIDES
18 GAUGE COLD ROLLED STEEL

AIR FOIL

COLD ROLLED STEEL
POWDER COAT FINISH

EXHAUST CONNECTION

POWDER-COATED STAINLESS STEEL 12.81" ID

WORKSURFACE

ORDERED SEPARATELY

CUPSINK

INCLUDED WITH WORKSURFACE

CABINETS

ORDERED SEPARATELY - SEE ELEVATION(S)

REMOTE BLOWER

ORDERED SEPARATELY

ALARM / MONITOR

ORDERED SEPARATELY AS REQUIRED

PLUMBING

SERVICE FIXTURE KITS ORDERED SEPARATELY AS REQUIRED
TO BE INSTALLED AND PLUMBED BY OTHER