



ENVIRCO™
CORPORATION
Innovators in clean air technology

ENVIRALAB® STERILITY MODULE

OPERATION MANUAL



LIMITED WARRANTY

Envirco warrants that all equipment manufactured by it and bearing its name will be free from defects in material and workmanship under normal use. The obligation of Envirco under this warranty is limited to the repair or replacement of any parts which are defective for a period of one year after invoice date, provided that Envirco receives written notice of such defect. For a period of 90 days after invoice date Envirco may effect such repairs or replacement, via qualified service personnel, at the equipment installation site provided that the equipment is located in the continental United States and that Envirco receives written notice of such defect. Excluded from this warranty are certain expendable items such as light tubes, filters, etc., as well as damage due to abuse or accident. Except for this warranty Envirco makes no warranty, expressed or implied, including but not limited to, those of description, quality merchantability, sample, fitness for a particular purpose or productiveness.



Table of Contents

Title	Page
A. UNCRATING INSTRUCTIONS	2
1.0 INTRODUCTION	3
2.0 INSTALLATION INSTRUCTIONS	4
3.0 OPERATING TECHNIQUES	5
3.1 Enviralab® Sterility Module	5
3.2 Ultraviolet Lamp Data	5
3.3 Ultraviolet Radiation Lethal Doses	6
3.4 Wall Area Surfaces	7
3.5 When the Module has been idle	7
3.6 Instruments, Containers, Fixtures, etc.	7
3.7 Unused Items	7
3.8 Obstructions	7
3.9 Particle-producing Products	7
3.10 Avoid Storing Items on Top of Module	7
3.11 Operator Precautions	7
3.12 While Working at the Module	8
3.13 Summary	8
4.0 MAINTENANCE AND SERVICING	
4.1 Prefilter on Top of the Module	9
4.2 When to Replace HEPA Filter	9
4.3 HEPA Filter Removal and Replacement	9
4.4 Motor/Blower	10
4.5 Lamp Maintenance	10
4.6 Velocity Gauge Calibration	11
5.0 TROUBLE SHOOTING	12-13
6.0 ELECTRICAL SCHEMATIC	14
7.0 ENGINEERING DATA	15
8.0 PARTS LIST	
8.1 ESM-3 - 36" ENVIRALAB Sterility Module	16
8.2 ESM-4 - 48" ENVIRALAB Sterility Module	17
8.3 ESM-6 - 70" ENVIRALAB Sterility Module	18



Uncrating Instructions

A. UNCRATING INSTRUCTIONS

The ENVIRCO equipment should be uncrated and inspected for shipping damage immediately upon arrival. If any damage is observed, a claims report should be filled out and promptly sent to the responsible carrier. Otherwise, uncrate and examine for internal damage.

If shipping damage is discovered inside the crating, file claim with the responsible carrier immediately. Shipping components list and actual material received should be compared and any shortages reported to ENVIRCO immediately.

NOTE: Remove shipping blocks inside blower housing from motor/
blower assembly(s).



Introduction

1.0 INTRODUCTION

The Enviralab® Sterility Module is a completely self-contained clean air product that provides a bio-clean, Class 100 environment (current Federal Standard 209) within its work area. The unit is designed for product protection only so that surrounding particulate contamination cannot reach the work area within the Module. At the same time, airborne contamination generated within the work area is swept away by the unique laminar airflow pattern.

Air enters the Module through a prefilter in the top of the cabinet. A blower then supplies air to the work area through a High Efficiency Particulate Air (HEPA) filter. The HEPA filter removes all particles 0.3 microns and larger in size with an efficiency of 99.99%. Air moves uniformly through the work area at a velocity of 90 feet per minute ($\pm 20\%$) and exits at the front of the Module.



Installation Instructions

2.0 INSTALLATION INSTRUCTIONS

The Module is ready for operation as received and should be set up as follows:

- 2.1 Locate Module on a sturdy laboratory bench or table (on a solid floor for Modules equipped with a Support Stand).
- 2.2 Level Module, or Module and Support Stand, by adjusting the four leveling feet located at the corners.

Note: Enviralab Sterility Module is shipped separately from support Stand. When Support Stand is used, the leveling feet must be removed from the Module and installed on the Support Stand. Support Stand should be located and leveled. The Module may then be placed on the top of the Support Stand.

- 2.3 Remove packaged materials from the work enclosure. Connect special electrical plug located on upper side of air diffuser screen to matching outlet in roof of work area. Secure air diffuser screen in place with nuts and bolts provided and then install fluorescent and ultraviolet lights.

Note: Do not work in module while ultraviolet light is on.
See cautions listed in Section 3.1.

- 2.4 Wipe interior surfaces of the work area with a mild disinfectant solution.
- 2.5 Plug Module into 120 volt, 60 cycle, 20 amp, grounded 5-15 R power receptacle.
- 2.6 Turn unit on by operating fan switch located on control panel. Unit will provide a clean atmosphere within five minutes.
- 2.7 Check air velocity by observing velocity gauge on control panel. Velocity reading should be in the black zone of the airflow gauge and may be adjusted via the control knob.
- 2.8 The light control switch is a center "off" type. The "up" position controls fluorescent lights; the "down" position controls the ultraviolet light.

Note: Do not work in module while ultraviolet light is on.
See cautions listed in Section 3.1.



Operating Techniques

3.0 OPERATING TECHNIQUES

Adherence to the following procedures will assure maximum unit effectiveness and operator safety.

3.1 The Enviralab® Sterility Module

The Enviralab® Sterility Module is equipped with an Ultraviolet Short Wavelength Germicidal Lamp for surface decontamination. The Lamp is intended for use in sterilizing work area surfaces and equipment before using the Module or for decontaminating surfaces after use.

Caution: The Lamp is not to be used while an operator is using the bench as certain health hazards may result.

3.2 Ultraviolet Lamp Data

The 25 and 30 watts nominal ultraviolet output, 253.7 Angstroms peak output, average intensity at lamp 6500 μ w. per cm^2 , average intensity at work surface 180 μ w. per cm^2 . (Average at 100 hours, initial rating 20% higher, approximate life, 7200 hours.)

Ultraviolet sterilization is a surface effect. Therefore, there must be no objects within the field which cast a shadow if complete sterilization is to be achieved.



3.3 Ultraviolet Radiation Lethal Doses

Micro-Organism	Lethal Dose for 180 μ W/Cm ² Radiation Intensity at Work Surface		
	<u>90% Kill</u>	<u>99% Kill</u>	<u>99.99% Kill</u>
YEAST (AVERAGE)	22.2 SEC.	44.4 SEC.	1.48 MIN.
BREWER'S YEAST	55.6 SEC.	1.6 MIN.	3.7 MIN.
FUNGI (MOULDS)	2.8-27.8 MIN.	5.6-55.6 MIN.	.2-1.9 HRS.
PROTOZOA	5.6-9.3 MIN.	11.2-18.6 MIN.	22.4-37.2 MIN.
ALGAE, BLUE-GREEN	27.8-55.6 MIN.	.9-1.9 HRS.	1.9-3.7 HRS.
Moulds			
Aspergillus Nigea (bread)	9.3 min.	18.6 min.	37.2 min.
Aspergillus Amstelodami (meat)	6.5 min.	13 min.	26 min.
Cladosporium Herbarum (cold sores)	2.8-6.5 min.	5.6-13 min.	11.2-26 min.
Penicillium Chrysogenum (fruit)	2.8-4.6 min.	5.6-9.3 min.	11.2-18.5 min.
Mucor Mucedo (meat, bread, fat)	4.6-6.5 min.	9.3-13 min.	18.5-26 min.
Scopulariopsis brevicaulis (cheese)	4.6-7.4 min.	9.3-14.8 min.	18.5-29.6 min.
Rhizopus nigricans (cheese)	27.8 min.	55.6 min.	1.9 hrs.

Adapted from Summer, Dr. W., *Ultraviolet and Infrared Engineering*, Pitman, 1962.

High intensity ultraviolet radiation causes ozone generation which may cause personnel discomfort in a small, poorly ventilated laboratory. Lamp should be left on only as needed, as determined by the lethal dose estimations given in the chart above.

CAUTION

The ultraviolet lamp should never be directly viewed with the eyes. Damage to the skin can also occur if exposed arms and hands are introduced into bench when the lamp is on. The injurious effects are similar to those of sunburn from overexposure to the sun. Recommended safe exposure limit to the intensities present in the Enviralab® Sterility Module is 30 seconds to 1 minute.

The permissible concentration for exposure during an 8-hour day is 0.1 ppm by the OSHA Regulations. At twice this concentration and above, an odor irritation, dry cough, drying of nasal passages, smarting of the eyes and headache symptoms occur. If any of these above mentioned signs are noticed, ultraviolet illumination should be discontinued unless adequate ventilation can be introduced into the laboratory.



3.4 Wall Area Surfaces

Wall area surfaces should be kept clean and free of particles. This area should be wiped out daily with a cloth dampened with a normal disinfectant solution.

3.5 When the Module has been idle

When the Module has been idle or when activities change, the work surfaces should be wiped clean as in 3.2 and the blower should be allowed to operate for at least 5 minutes before activities commence.

3.6 Instruments, Containers, Fixtures, etc.

All material (instruments, containers, fixtures, etc.) should be cleaned before being placed inside the work area.

3.7 Unused Items

The work area should be kept free of unused items to maximize work space and cleanliness levels.

3.8 Obstructions

Avoid placing obstructions directly between the clean air supply and critical activities.

3.9 Particle-producing Products

Lead pencils, paper products or other linting or particle-producing products are not recommended for use in the Module.

3.10 Avoid Storing Items on Top of Module

Storing items on top of Module should always be avoided as this will starve the air intake filters and block intake airflow.

3.11 Operator Precautions

Care should be taken to prevent operator's hands, forearms, sleeves or other loose clothing from coming into direct contact with the critical work.



3.12 While Working at the Module

Hair or eyelashes should not be rubbed while working at the Module as this can cause both shedding and contact contamination. Always turn away when coughing or sneezing.

3.13 Summary

Summary: Strict adherence to established sterile techniques will serve to maximize the contamination control benefits provided by the Enviralab Sterility Module.



Maintenance and Servicing

4.0 MAINTENANCE AND SERVICING

4.1 Prefilters on Top of the Module

Prefilters on top of the Module should be replaced every 30 to 60 days, depending upon the amount of dust and lint in the surrounding room.

4.2 When to Replace HEPA Filter

Final (HEPA) filter must be replaced only when the airflow drops below an acceptable level with new prefilters. HEPA filters will normally require replacing every 2 to 3 years.

4.3 HEPA Filter Removal and Replacement (See Figures 1 & 2)

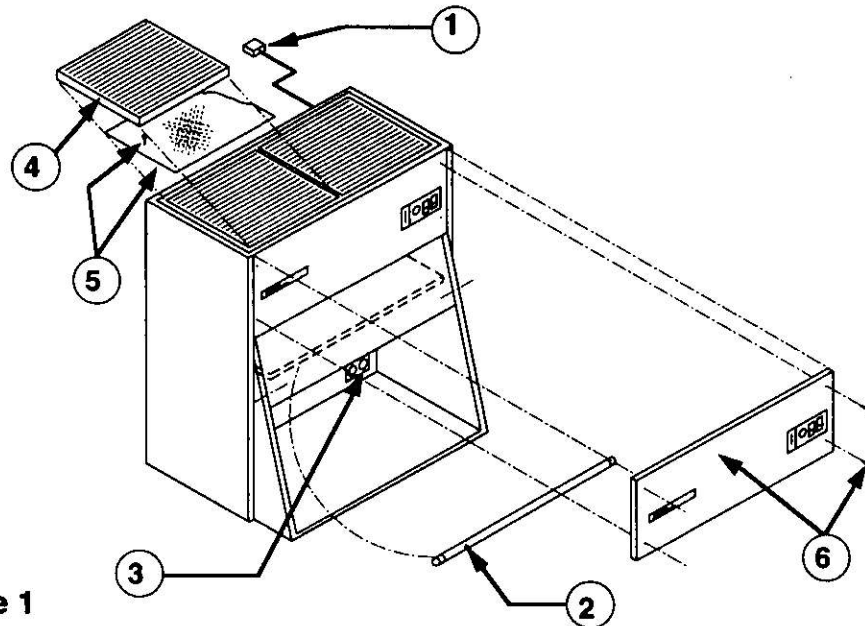

Figure 1

- (a) Unplug Module from power source and remove Lamp tubes. ① ②
- (b) Disconnect all apparatus from duplex electrical outlet connection. ③
- (c) Remove prefilters from top of unit. ④
- (d) Remove screws holding air intake screen and remove screen. ⑤
- (e) Unplug control panel connector and air gauge tubes. Remove screws from front panel and remove panel. ⑥



4.3 HEPA Filter Removal and Replacement (continued)

Figure 2

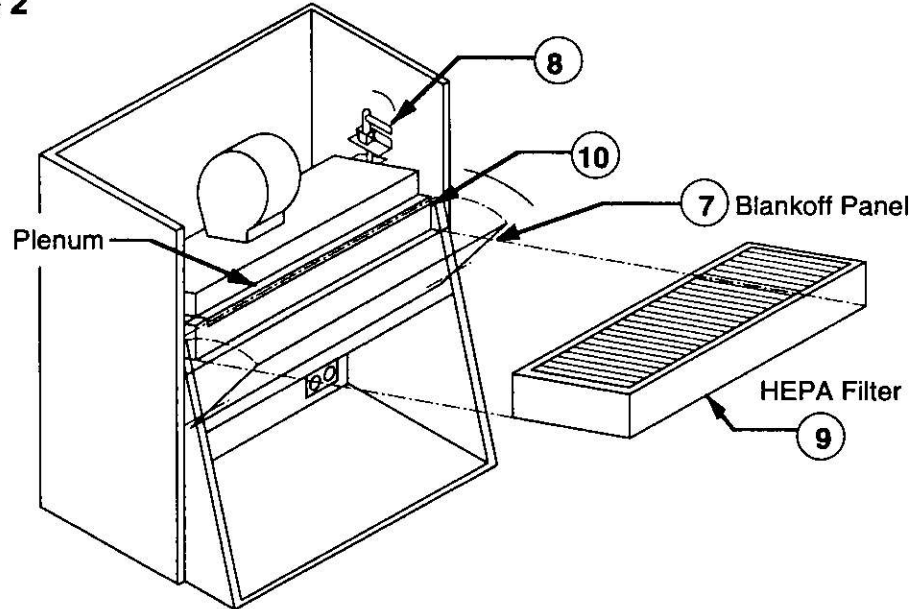

- (f) Rotate lower front panel from top (pull towards you). (7)
- (g) Lift toggle clamp handles, located @ sides of blower plenum, 180° to raise plenum off HEPA filter. (8)
- (h) Carefully . . . pull out the HEPA filter to the front of the unit. (9)
- (i) Clean surface of filter sealing frame. (10)

4.4

Motor/blower should require no servicing. In case of motor failure, a new motor/blower unit may be ordered directly from ENVIRCO. Access to motor/blower is through prefilter opening on top of unit.

4.5

Lamp maintenance requires only occasional replacement of the lamp tubes. This is easily done from within the work area. Ultraviolet lamp requires a lamp starter, which is located on the diffuser screen. Starter may be replaced by removing lamp, then twisting starter until it is free. In case of ballast failure, ballast can be replaced by removing prefilters for access to blower compartment.

Caution: Do not look directly up into work area when ultraviolet light is on.



4.6 Velocity Gauge Calibration

Velocity gauge calibration may be checked as follows:

- (a) Measure air velocity in the unit with an air velometer (Alnor Model #3002, or equivalent). Measure air velocity on a 6" grid at 6" below diffuser screen.
- (b) Average all readings to determine average air velocity. (Must be corrected for altitude.)
- (c) Air gauge on control panel is set to read between 70 and 110 fpm with the center line at 90 fpm (corrected to STP). Gauge calibration can be adjusted by the screw at the top of the gauge.

Note: Blockage of sensing tubes from gauge to blower can cause incorrect gauge calibration.

Note: Complete service for the Enviralab® Sterility Module is available nationwide by factory-trained qualified specialists. Services available include filter replacement, repairs, and unit testing and certification to current Federal Standard 209.

For additional information contact:

ENVIRCO
5601 Balloon Fiesta Parkway, N. E.
Albuquerque, New Mexico 87113
Tel: 505-345-3561
Fax: 505-345-8875
Toll-Free 800-545-6598



Troubleshooting

5.0 TROUBLESHOOTING

If malfunctions occur, proceed in numbered order:

Symptom	Causes	Action
1. Air Supply Inoperative	a. Power failure	a. Check building power plug.
	b. Switch or internal	b. Check unit wiring and switch wiring failure by enclosed electrical schematic. Replace defective components.
	c. Faulty speed control	c. Check speed control and Replace if required.
	d. Motor failure	d. Replace motor/blower unit.
2. Inoperative Lights	a. Incorrectly installed	a. Check for proper installation.
	b. Tube failure	b. Replace Tubes.
	c. Wiring, switch or UV-starter failure	c. Check wiring and switch by enclosed electrical schematic. Check UV-starter. Replace defective component.
	d. Ballast failure	d. Replace ballast.



5.0 TROUBLESHOOTING (Continued)

Symptom	Causes	Action
3. Low Air Velocity	a. Speed control set too low	a. Check speed control knob on front control panel.
	b. Dirty prefilter	b. Replace prefilter. (Recommended replacement interval is every 30-60 days.)
	c. Dirty HEPA filter	c. Replace HEPA filter.
	d. Velocity gauge out of calibration	d. Recalibrate gauge.
	e. Blocked or damaged sensing tubes	e. Check tubes for obstructions or damage.
4. Excessive Noise or Vibration	a. Blower bearing damage, loose mounting or loose blower wheel	a. Check motor/blower, tighten bolts.
		b. Replace motor/blower.
5. Work Area Contamination	a. Damaged HEPA filter	a. Find leak by leak test procedure and repair with silicon sealants or replace filter.



Electrical Schematic

6.0 ELECTRICAL SCHEMATIC

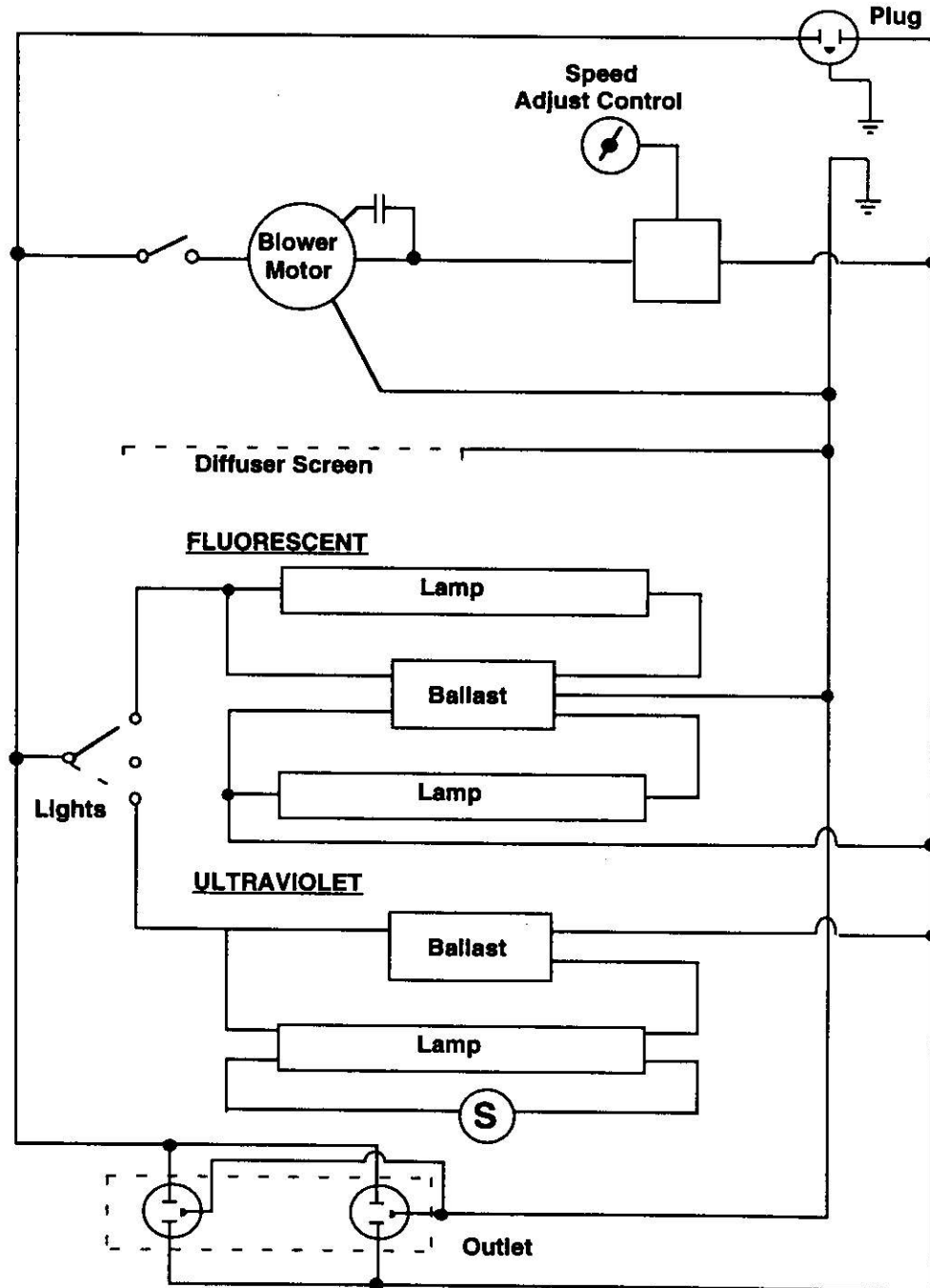



Engineering Data

7.0 ENGINEERING DATA

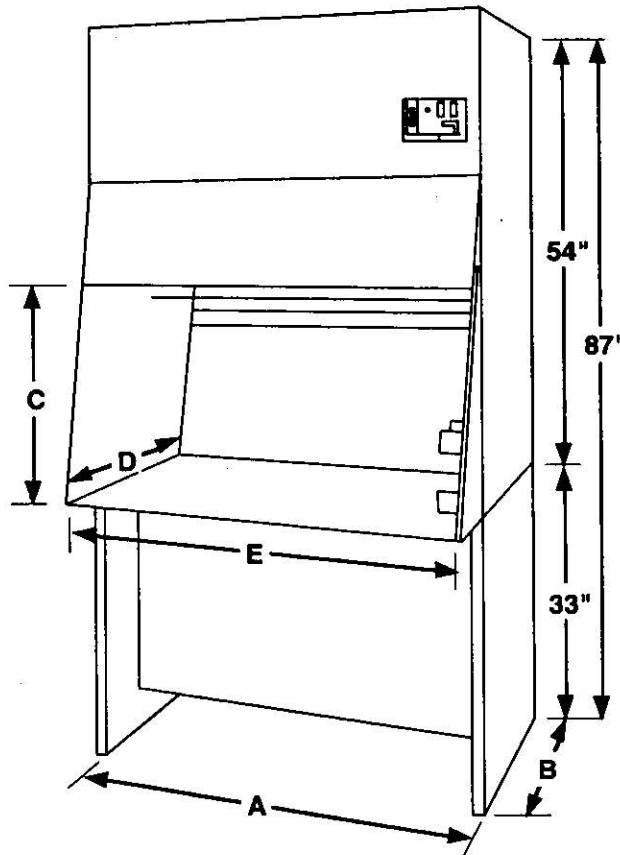

Model Number	Product Number	Dimensions in Inches (cm)					Average CFM @ 90 FPM	BTU/ Hour	Power Required Amps @ 115 V	Number of Blowers	Ship Weight Lbs. (Kg.)
		A	B	C	D	E					
ESM - 3	10758	35.00 (88.9)	32.25 (81.92)	24.50 (62.23)	26.125 (66.36)	33.50 (85.09)	540	3100	6.0	1	265 (120.0)
ESM - 4	10166	47.00 (119.38)	32.25 (81.915)	28.00 (71.120)	26.125 (66.357)	44.50 (113.030)	720	3300	8.0	1	370 (168.2)
ESM - 6	10315	70.00 (177.80)	32.25 (81.915)	28.00 (71.120)	26.125 (66.357)	67.50 (171.450)	1080	4100	10.0	1	510 (231.8)

SPECIFICATIONS ARE SUBJECT TO CHANGE WITHOUT NOTICE AND WITHOUT INCURRING LIABILITY FOR MODIFICATIONS TO EQUIPMENT PREVIOUSLY SOLD.



Parts List - ESM-3

8.0 PARTS LIST

8.1 ESM-3: 36" ENVIRALAB® STERILITY MODULE

<u>Item</u>	<u>Part Number</u>
HEPA filter, one required, 32" x 24" x 5-7/8"	69357
Blower/motor assembly	23567
Blower only	60466
Motor only, 1/4 hp, 115 v. 60 hz., single phase	62857
Fluorescent ballast assembly (with wire connector)	23558
Fluorescent ballast only, not assembled	60069
U.V. ballast assembly (with wire connector)	23557
U.V. ballast only, not assembled	62859
Lamp starter	60268
U.V. lamp (one required)	60860
Fluorescent lamp (two required)	90821
Prefilters (one required) 22" x 32-1/8" x 1"	62862
Speed Control	60446
Velocity Guage	61056
Potentiometer	30299

To place a direct order call:

ENVIRCO
5601 Balloon Fiesta Parkway, N. E.
Albuquerque, New Mexico 87113
Tel: 505-345-3561
Fax: 505-345-8875
Toll-Free 800-545-6598



Parts List - ESM-4

8.0 PARTS LIST

8.2 ESM -4: 48" ENVIRALAB® STERILITY MODULE

<u>Item</u>	<u>Part Number</u>
HEPA filter, one required, 44-1/8" x 24" x 5-7/8"	60080
Blower/motor assembly	20299
Blower only	60466
Motor only, 1/3 hp, 115 v. 60 hz., single phase	62260
Fluorescent ballast assembly (with wire connector)	20077
Fluorescent ballast only, not assembled	65050
U.V. ballast assembly (with wire connector)	20296
U.V. ballast only, not assembled	60202
Lamp starter	60268
U.V. lamp (one required)	60265
Fluorescent lamp (two required)	64650
Prefilters (two required) 22" x 23-3/8" x 1"	60370
Speed Control	60446
Velocity Gauge	61056
Potentiometer	30299

To place a direct order call:

ENVIRCO
5601 Balloon Fiesta Parkway, N. E.
Albuquerque, New Mexico 87113
Tel: 505-345-3561
Fax: 505-345-8875
Toll-Free 800-545-6598



Parts List - ESM-6

8.0 PARTS LIST

8.3 ESM-6: 70" ENVIRALAB® STERILITY MODULE

<u>Item</u>	<u>Part Number</u>
HEPA filter, one required, 67" x 24" x 5-7/8"	61659
Blower/motor assembly	32512
Blower only	61642
Motor only, 1/2 hp, 115 v. 60 hz., single phase	61657
Fluorescent ballast assembly (with wire connector)	32151
Fluorescent ballast only, not assembled	61656
U.V. ballast assembly (with wire connector)	20296
U.V. ballast only, not assembled	60202
Lamp starter	60268
U.V. lamp (one required)	60265
Fluorescent lamp (two required)	61660
Prefilters (three required) 22" x 22-3/8" x 1"	60370
Speed Control	60446
Velocity Guage	61056
Potentiometer	30299

To place a direct order call:

ENVIRCO
5601 Balloon Fiesta Parkway, N. E.
Albuquerque, New Mexico 87113
Tel: 505-345-3561
Fax: 505-345-8875
Toll-Free 800-545-6598

The logo consists of a square divided into four quadrants, each containing a stylized circular or semi-circular shape. To the right of this icon, the word "ENVIRO" is written in a bold, sans-serif font. A horizontal line is drawn below "ENVIRO", and the word "CORPORATION" is written in a smaller, spaced-out, sans-serif font below the line.

ENVIRO
C O R P O R A T I O N

5601 Balloon Fiesta Parkway N.E. • Albuquerque • New Mexico 87113 • U.S.A.
(505) 345-3561 • (800) 545-6598