

Disposable Reagent Reservoirs

25 ml, 50 ml, 55 ml and 100 ml



25 ml Reagent Reservoir, polystyrene



25 ml Reagent Reservoir, 3 Divisions, polystyrene

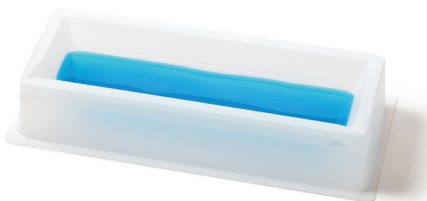

55 ml Reagent Reservoir, polystyrene or PVC

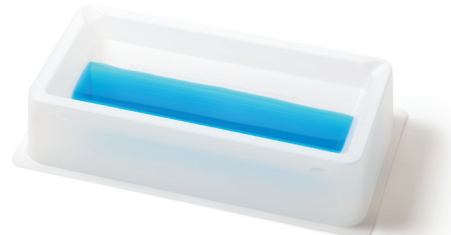

100 ml Reagent Reservoir, polystyrene



50 ml Reagent Reservoir for automated platforms, polystyrene



100 ml Reagent Reservoir for automated platforms, polystyrene

PRODUCT HIGHLIGHTS

Biotix disposable reagent reservoirs are designed for use with multi-channel pipetting applications and can accommodate up to 12-channel pipettes. Angled sides and a V-shaped bottom allow maximum recovery of reagents. All reservoirs feature internal graduated volume lines and pour-spouts on the corners. Choose from opaque white polyvinyl chloride (PVC) or high clarity polystyrene (PS) in several packaging configurations.

FEATURES	BENEFITS
Molded-in graduated volume lines and corner pour-spouts	Precise volume measurements and eliminates messy decanting of solutions
Angled sides and V-shaped bottom	Maximum recovery of reagents - reduces waste
Polystyrene reservoirs available in single well, or 3-well divided formats	Select the appropriate reservoir whether working in traditional single reagent format, or manipulating three different reagents at a time
BioReady™ Certified	Reservoirs are certified free of RNase, DNase and endotoxins (pyrogens)

Product Dimensions

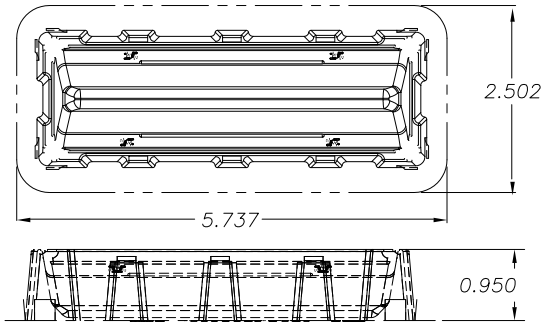

SR-0025-5SWM, SR-0025-BWM, SR-0025-1SWM

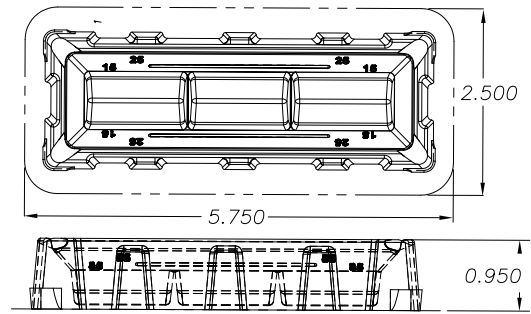

SR-0025-53SWM, SR-0025-B3WM, SR-0025-13SWM

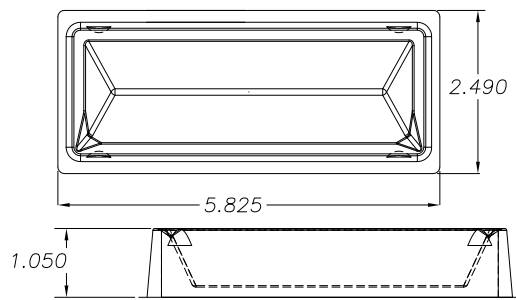

SR-0055-5SNM, SR-0055-1SNM, SR-0055-BNM

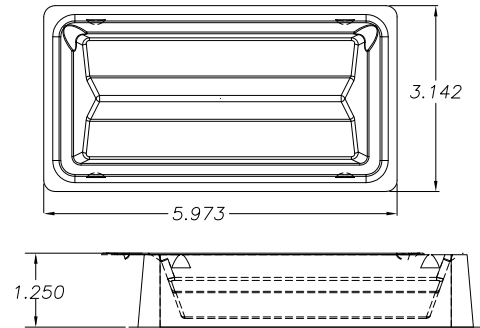

SR-0100-5SNM, SR-0100-1SNM, SR-0100-BNM

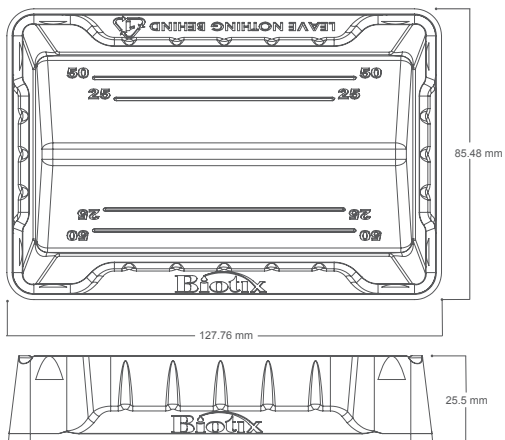

SR-0050-1SC, SR-0050-5SC, SR-0050-BC

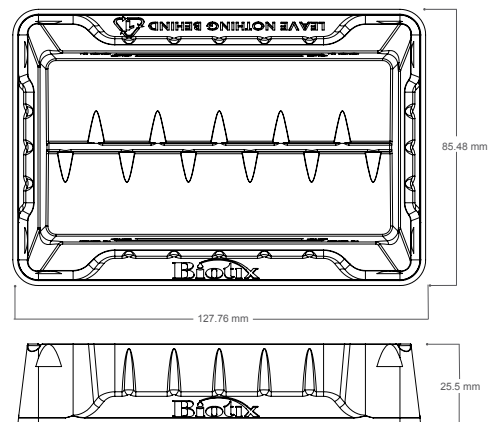

SR-0100-1SC, SR-0100-5SC, SR-0100-BC

Ordering Information

Biotix Part No.	Description	Volume	Packaging
SR-0025-5SWM	Reagent Reservoir, polystyrene, pre-sterile	25 ml	5 reservoirs/bag, 10 bags/pack
SR-0025-1SWM	Reagent Reservoir, polystyrene, pre-sterile	25 ml	1 reservoir/bag, 25 bags/pack
SR-0025-BWM	Reagent Reservoir, polystyrene	25 ml	100 reservoirs/pack, bulk
SR-0025-53SWM	Divided Reagent Reservoir, 3-wells, polystyrene, pre-sterile	25 ml	5 reservoirs/bag, 10 bags/pack
SR-0025-13SWM	Divided Reagent Reservoir, 3-wells, polystyrene, pre-sterile	25 ml	1 reservoir/bag, 25 bags/pack
SR-0025-B3WM	Divided Reagent Reservoir, 3-wells, polystyrene	25 ml	100 reservoirs/pack, bulk
SR-0050-1SC	Reagent Reservoir for automated platforms, polystyrene, pre-sterile	50 ml	1 reservoir/bag, 100 bags/case
SR-0050-5SC	Reagent Reservoir for automated platforms, polystyrene, pre-sterile	50 ml	5 reservoirs/bag, 40 bags/case
SR-0050-BC	Reagent Reservoir for automated platforms, polystyrene	50 ml	100 reservoirs/case, bulk
SR-0055-5SNM	Reagent Reservoir, polystyrene, pre-sterile	55 ml	5 reservoirs/bag, 10 bags/pack
SR-0055-1SNM	Reagent Reservoir, polystyrene, pre-sterile	55 ml	1 reservoir/bag, 25 bags/pack
SR-0055-BNM	Reagent Reservoir, polyvinyl chloride (PVC)	55 ml	100 reservoirs/pack, bulk
SL-0055-BCM	Lid for Reagent Reservoir, APET	n/a	20 lids/bag, 1 bag/pack
SR-0100-1SC	Reagent Reservoir for automated platforms, polystyrene, pre-sterile	100 ml	1 reservoir/bag, 100 bags/case
SR-0100-5SC	Reagent Reservoir for automated platforms, polystyrene, pre-sterile	100 ml	5 reservoirs/bag, 40 bags/case
SR-0100-BC	Reagent Reservoir for automated platforms, polystyrene	100 ml	100 reservoirs/case, bulk
SR-0100-5SNM	Reagent Reservoir, polystyrene, pre-sterile	100 ml	5 reservoirs/bag, 10 bags/pack
SR-0100-1SNM	Reagent Reservoir, polystyrene, pre-sterile	100 ml	1 reservoir/bag, 25 bags/pack
SR-0100-BNM	Reagent Reservoir, polystyrene	100 ml	100 reservoirs/pack, bulk

©2013, Biotix, Inc. All rights reserved

Biotix, Fluid Innovation, Delta Filter, X-Resin, Blade, FlexFit, Statix, Leave Nothing Behind, BioReady, Tip Eject, and XTreme Quality are registered trademarks or trademarks of Biotix, Inc. All other brands and names contained herein are the property of their respective owners.

000000 10/13