

Tucked under, yet super accessible.



24/7
PROTECTION



Preconfigured for easy ordering and maximum value.

The Starsys® Preconfigured Mobile Under Counter Cart is a polymer based, highly adaptive storage cart, that enhances productivity and space efficiency by empowering the end user with the ability to easily relocate, reposition, and transport stored contents as-needed. This ability helps to create a more flexible work space and to meet your changing workflow demands.

Features & Benefits:

- Durable easy-to- clean, polymer enclosures that won't chip, peel, or rust...ever
- Robust and stable structure for even the most sensitive equipment.
- Security options including non-lock, key locking, and PIN locking with key override
- Mobility of contents to place where needed
- Molded with Microban® antimicrobial protection that works 24/7 for an added level of protection against bacteria, mold and mildew.



Simple selections.



This Under Counter Storage cart group includes several of the most common configurations that have been preconfigured making them easy-to-order. These preconfigured units come in three different heights, there are three different locking options, and a choice of either door access to contents or a bank of drawers for item storage. All are mobile units designed to increase area volume storage by fitting either under a desk/knee well, standard height counter top or a standing work surface.

Starsys carts are design to be durable. All preconfigured Under Counter carts come with High Density Polyethylene (HDPE) tops, black door / drawer pulls, and 3 inch casters.



Starsys Under Counter Cart with Door



Starsys Under Counter Cart with Drawers

Starsys Under Counter Carts

Non-Locking		Key Locking		PIN Locking	
76463-298	34" (889mm) Tall, Single-Wide w/ Door	76463-286	28" (737mm) Tall, Single-Wide w/ Drawers	76463-290	28" (737mm) Tall, Single-Wide w/ Drawers
76463-310	40" (1067mm) Tall, Single-Wide w/ Door	76463-292	34" (889mm) Tall, Single-Wide w/ Drawers	76463-300	34" (889mm) Tall, Single-Wide w/ Drawers
		76463-294	34" (889mm) Tall, Single-Wide w/ Door	76463-302	34" (889mm) Tall, Single-Wide w/ Door
		76463-306	40" (1067mm) Tall, Single-Wide w/Door	76463-312	40" (1067mm) Tall, Single-Wide w/ Drawers
				76463-314	40" (1067mm) Tall, Single-Wide w/ Door

U.S. part numbers listed.

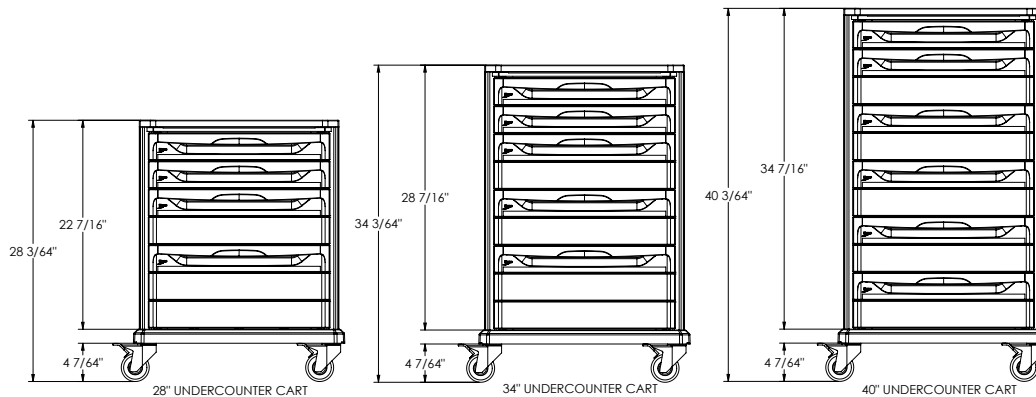

L07-178 6/20

© 2022 InterMetro Industries Corporation, Wilkes-Barre, PA 18705
 *MICROBAN is a registered trademark of Microban Products Company. Microban Antimicrobial product protection inhibits the growth of mold, mildew, fungus, and bacteria that cause odor and stains on surfaces.

0822 Lit. No. 130255W



VWR.COM

Prices, product, and/or services details are current when published and subject to change without notice. | Certain products or services may be limited by federal, state, provincial, or local regulations. | VWR, part of Avantor, makes no claims or warranties concerning sustainable/green products. Any claims concerning sustainable/green products are the sole claims of the manufacturer and not those of VWR International, LLC and/or Avantor, Inc. or affiliates. All prices are in US dollars unless otherwise noted. Offers valid in US and Canada unless otherwise noted, void where prohibited by law or company policy, while supplies last. | Trademarks are owned by Avantor, Inc. or its affiliates, unless otherwise noted. | Visit vwr.com to view our privacy policy, trademark owners, and additional disclaimers. © 2022 Avantor, Inc. All rights reserved.