

VWR lab benches and tables

01. ERGONOMIC & FLEXIBLE

02. HEAVY-DUTY STEEL
CONSTRUCTION



VWR benches and tables are designed for real world functionality

VWR, part of Avantor, supports you throughout every phase of furnishing your lab. Our team of experienced sales and support staff is dedicated to supplying original, innovative solutions – on time and within budget.

Our portfolio of lab benches and tables are ergonomically designed to meet the needs of laboratory personnel. There are many possible adjustments and accessories available, all designed for real-world functionality.

All options are height adjustable and can be equipped with casters to create a mobile workstation solution. Available in light neutral-colored frames with either laminate or black phenolic worksurfaces.

Benches and tables ship unassembled. Assembled shipping and installation services available upon request.



Learn more about furniture products, services and customer service



EVERYTHING YOU NEED FROM ONE SOURCE

- Biosafety cabinets
- Carts
- Casework: metal, wood, plastic & stainless steel
- Chairs & stools
- Countertops
- Emergency eyewash stations
- Environmental rooms
- Fume hoods
- Glassware washers
- Office furniture
- Prefabricated cleanrooms
- Shelving
- Safety cabinets
- Sinks & fixtures
- Tables/workstations
- Task lighting
- Undercounter refrigerators/freezers
- Walk-in cold rooms
- Water systems

VWR REDISHIP

VWR REDISHIP offers you many laboratory furniture items in a matter of days*. If you're ready to renovate your lab at a moment's notice, or if you need to quickly replace lab chairs, tables, carts, shelving, steel casework or fume hoods, VWR REDISHIP is ready when you are.

VWR.COM

We've made it simple for you to find the most comprehensive, up-to-date information about our lab furniture offering on vwr.com, one of the most advanced and customer-focused websites in the industry. You can also access our literature portfolio, installation video, and project photos at our dedicated furniture website, vwr.com/furniture.

BENCH SELECTOR

Design a lab workstation complete with accessories in four easy steps. The configurator walks you through the simple process of selecting a VWR bench and adding accessories to build a lab workstation that best meets your needs. It has never been easier to design and quote a lab workstation! Visit vwr.com/benchselector to discover this tool.

*Most REDISHIP items ship within 72 hours of order. All items are subject to availability at time of order. Large-quantity orders may require longer lead times. 72-hour shipping time is based on immediate credit approval.

VWR® C-LEG BENCHES

- Suitable for heavy loads up to 1100 lbs.
- Ergonomic and highly adaptable to the needs of the user
- Flexible, modular design
- Offered in manual, handcrank, or motorized frame styles
- Offering a wide range of accessories to meet any need

Paint color: light neutral

Manual



Max load: 1100 lbs.

Handcrank



Max load: 440 lbs.

Motorized



Max load: 880 lbs (dynamic)/1100 lbs. (static)

VWR® C-LEG LAB BENCHES

Worksurface	Width	Depth*	Height	Cat. No.
Manual Frame Style				
Phenolic	48"	30"	26.62 to 44.34"	89524-198
Phenolic	48"	36"	26.62 to 44.34"	89524-832
Phenolic	60"	36"	26.62 to 44.34"	89524-834
Phenolic	72"	30"	26.62 to 44.34"	89524-200
Phenolic	72"	36"	26.62 to 44.34"	89524-836
Laminate	48"	30"	26.62 to 44.34"	89524-202
Laminate	48"	36"	26.62 to 44.34"	89524-838
Laminate	60"	30"	26.62 to 44.34"	89524-204
Laminate	60"	36"	26.62 to 44.34"	89524-840
Laminate	72"	30"	26.62 to 44.34"	89524-206
Laminate	72"	36"	26.62 to 44.34"	89524-842
Handcrank Frame Style				
Phenolic	48"	30"	26.82 to 40.60"	89524-270
Phenolic	48"	36"	26.82 to 40.60"	89524-904
Phenolic	60"	30"	26.82 to 40.60"	89524-268
Phenolic	60"	36"	26.82 to 40.60"	89524-906
Phenolic	72"	30"	26.82 to 40.60"	89524-272
Phenolic	72"	36"	26.82 to 40.60"	89524-906

*Depth with uprights attached are 32.625" for 30"D tables and 38.625" for 36"D tables, due to depth of uprights and notched table top.

Worksurface	Width	Depth*	Height	Cat. No.
Laminate	48"	30"	26.82 to 40.60"	89524-192
Laminate	48"	36"	26.82 to 40.60"	89524-826
Laminate	60"	30"	26.82 to 40.60"	89524-194
Laminate	60"	36"	26.82 to 40.60"	89524-828
Laminate	72"	30"	26.82 to 40.60"	89524-196
Laminate	72"	36"	26.82 to 40.60"	89524-830
Motorized Frame Style				
Phenolic	48"	30"	27.80 to 43.55"	89524-334
Phenolic	48"	36"	27.80 to 43.55"	89524-970
Phenolic	60"	30"	27.80 to 43.55"	89524-356
Phenolic	60"	36"	27.80 to 43.55"	89524-992
Phenolic	72"	30"	27.80 to 43.55"	89524-336
Phenolic	72"	36"	27.80 to 43.55"	89524-972
Laminate	48"	30"	27.80 to 43.55"	89524-338
Laminate	48"	36"	27.80 to 43.55"	89524-974
Laminate	60"	30"	27.80 to 43.55"	89524-340
Laminate	60"	36"	27.80 to 43.55"	89524-976
Laminate	72"	30"	27.80 to 43.55"	89524-342
Laminate	72"	36"	27.80 to 43.55"	89524-978

*Depth with uprights attached are 32.625" for 30"D tables and 38.625" for 36"D tables, due to depth of uprights and notched table top.

1 Notched



Shown above: single notched top for single bay uprights

1 Double Notched



Shown above: double notched top for double bay uprights

VWR® C-LEG BENCH FRAME ONLY

Width	Depth	Height	Cat. No
Manual Frame Style			
48"	30"	26.62 to 44.34"	10682-750
48"	36"	26.62 to 44.34"	10682-780
60"	30"	26.62 to 44.34"	10682-776
60"	36"	26.62 to 44.34"	10682-782
72"	30"	26.62 to 44.34"	10682-778
72"	36"	26.62 to 44.34"	10682-784
Handcrank Frame Style			
48"	30"	26.82 to 40.60"	10682-786
48"	36"	26.82 to 40.60"	10682-752
60"	30"	26.82 to 40.60"	10682-788
60"	36"	26.82 to 40.60"	10682-754
72"	30"	26.82 to 40.60"	10682-790
72"	36"	26.82 to 40.60"	10682-756
Motorized Frame Style			
48"	30"	27.80 to 43.55"	10682-758
48"	36"	27.80 to 43.55"	10682-764
60"	30"	27.80 to 43.55"	10682-760
60"	36"	27.80 to 43.55"	10682-766
72"	30"	27.80 to 43.55"	10682-762
72"	36"	27.80 to 43.55"	10682-768

VWR® C-LEG MOTORIZED BENCH FRAME WITH NOTCHED WORKSURFACE

Worksurface	Width	Depth	Cat. No.
Single Bay			
Phenolic	48"	32.625"	10682-650
Phenolic	48"	38.625"	10682-656
Phenolic	60"	32.625"	10682-652
Phenolic	60"	38.625"	10682-658
Phenolic	72"	32.625"	10682-654
Phenolic	72"	38.625"	10682-660
Laminate	48"	32.625"	10682-770
Laminate	48"	38.625"	10682-662
Laminate	60"	32.625"	10682-772
Laminate	60"	38.625"	10682-664
Laminate	72"	32.625"	10682-774
Laminate	72"	38.625"	10682-666
Double Bay			
Phenolic	60"	32.625"	10682-684
Phenolic	60"	38.625"	10682-704
Phenolic	72"	32.625"	10682-702
Phenolic	72"	38.625"	10682-706
Laminate	60"	32.625"	10682-708
Laminate	60"	38.625"	10682-712
Laminate	72"	32.625"	10682-710
Laminate	72"	38.625"	10682-714

Notched work surfaces add 2.625" to depth of table frame. Work surfaces for single bay uprights include 2 notches (left and right); work surfaces for double bay uprights include 3 notches (left, center, right)

VWR® C-LEG MANUAL BENCH FRAME WITH NOTCHED WORKSURFACE

Worksurface	Width	Depth	Cat. No.
Single Bay			
Phenolic	48"	32.625"	10682-568
Phenolic	48"	38.625"	10682-574
Phenolic	60"	32.625"	10682-570
Phenolic	60"	38.625"	10682-576
Phenolic	72"	32.625"	10682-572
Phenolic	72"	38.625"	10682-578
Laminate	48"	32.625"	10682-580
Laminate	48"	38.625"	10682-618
Laminate	60"	32.625"	10682-582
Laminate	60"	38.625"	10682-620
Laminate	72"	32.625"	10682-584
Laminate	72"	38.625"	10682-622
Double Bay			
Phenolic	60"	32.625"	10682-668
Phenolic	60"	38.625"	10682-672
Phenolic	72"	32.625"	10682-670
Phenolic	72"	38.625"	10682-674
Laminate	60"	32.625"	10682-676
Laminate	60"	38.625"	10682-680
Laminate	72"	32.625"	10682-678
Laminate	72"	38.625"	10682-682

Notched work surfaces add 2.625" to depth of table frame. Work surfaces for single bay uprights include 2 notches (left and right); work surfaces for double bay uprights include 3 notches (left, center, right)

VWR® C-LEG HANDCRANK BENCH FRAME WITH NOTCHED WORKSURFACE

Worksurface	Width	Depth	Cat. No.
Single Bay			
Phenolic	48"	32.625"	10682-624
Phenolic	48"	38.625"	10682-630
Phenolic	60"	32.625"	10682-626
Phenolic	60"	38.625"	10682-632
Phenolic	72"	32.625"	10682-628
Phenolic	72"	38.625"	10682-634
Laminate	48"	32.625"	10682-636
Laminate	48"	38.625"	10682-642
Laminate	60"	32.625"	10682-638
Laminate	60"	38.625"	10682-644
Laminate	72"	32.625"	10682-640
Laminate	72"	38.625"	10682-646
Double Bay			
Phenolic	60"	32.625"	10682-684
Phenolic	60"	38.625"	10682-688
Phenolic	72"	32.625"	10682-686
Phenolic	72"	38.625"	10682-690
Laminate	60"	32.625"	10682-692
Laminate	60"	38.625"	10682-696
Laminate	72"	32.625"	10682-694
Laminate	72"	38.625"	10682-698

Notched work surfaces add 2.625" to depth of table frame. Work surfaces for single bay uprights include 2 notches (left and right); work surfaces for double bay uprights include 3 notches (left, center, right)



11.81"D steel shelf with mounting brackets, can be positioned along the height of the upright.

Motorized frame with phenolic top



*Depth with uprights attached are 32.625" for 30"D tables and 38.625" for 36"D tables, due to depth of uprights and notched table top. Width dimensions shown above also include added width from uprights.

Motorized frame with phenolic top

VWR® C-LEG LAB BENCHES WITH SINGLE BAY UPRIGHTS AND STEEL SHELF

Worksurface	Width	Depth	Height	Width, Shelf	Cat. No.
Manual					
Phenolic	48.5"	32.625"	53.5"	48"	89524-230
Phenolic	48.5"	38.625"	53.5"	48"	89524-864
Phenolic	60.375"	32.625"	53.5"	60"	89524-231
Phenolic	60.375"	38.625"	53.5"	60"	89524-866
Phenolic	72"	32.625"	53.5"	72"	89524-232
Phenolic	72"	38.625"	53.5"	72"	89524-868
Laminate	48.5"	32.625"	53.5"	48"	89524-234
Laminate	48.5"	38.625"	53.5"	48"	89524-870
Laminate	60.675"	32.625"	53.5"	60"	89524-236
Laminate	60.675"	38.625"	53.5"	60"	89524-872
Laminate	72"	32.625"	53.5"	72"	89524-238
Laminate	72"	38.625"	53.5"	72"	89524-874
Handcrank					
Phenolic	48.5"	32.625"	53.5"	48"	89524-294
Phenolic	48.5"	38.625"	53.5"	48"	89524-930
Phenolic	60.375"	32.625"	53.5"	60"	89524-296
Phenolic	60.375"	38.625"	53.5"	60"	89524-932
Phenolic	72"	32.625"	53.5"	72"	89524-298
Phenolic	72"	38.625"	53.5"	72"	89524-934
Laminate	48.5"	32.625"	53.5"	48"	89524-300
Laminate	48.5"	38.625"	53.5"	48"	89524-936
Laminate	60.375"	32.625"	53.5"	60"	89524-302
Laminate	60.375"	38.625"	53.5"	60"	89524-938
Laminate	72"	32.625"	53.5"	72"	89524-304
Laminate	72"	38.625"	53.5"	72"	89524-940
Motorized					
Phenolic	48.5"	32.625"	53.5"	48"	89524-366
Phenolic	48.5"	38.625"	53.5"	48"	89525-002
Phenolic	60.375"	32.625"	53.5"	60"	89524-368
Phenolic	60.375"	38.625"	53.5"	60"	89525-004
Phenolic	72"	32.625"	53.5"	72"	89524-370
Phenolic	72"	38.625"	53.5"	72"	89525-006
Laminate	48.5"	32.625"	53.5"	48"	89524-372
Laminate	48.5"	38.625"	53.5"	48"	89525-008
Laminate	60.375"	32.625"	53.5"	60"	89524-374
Laminate	60.375"	38.625"	53.5"	60"	89525-010
Laminate	72"	32.625"	53.5"	72"	89524-376
Laminate	72"	38.625"	53.5"	72"	89525-012

VWR® C-LEG LAB BENCHES WITH SINGLE BAY UPRIGHTS AND TWO STEEL SHELVES

Worksurface	Width	Depth	Height	Width, Shelves	Cat. No.
Manual					
Phenolic	48.5"	32.625"	53.5"	48"	89524-240
Phenolic	48.5"	38.625"	53.5"	48"	89524-876
Phenolic	60.375"	32.625"	53.5"	60"	89524-242
Phenolic	60.375"	38.625"	53.5"	60"	89524-878
Phenolic	72"	32.625"	53.5"	72"	89524-244
Phenolic	72"	38.625"	53.5"	72"	89524-880
Laminate	48.5"	32.625"	53.5"	48"	89524-246
Laminate	48.5"	38.625"	53.5"	48"	89524-882
Laminate	60.675"	32.625"	53.5"	60"	89524-248
Laminate	60.675"	38.625"	53.5"	60"	89524-884
Laminate	72"	32.625"	53.5"	72"	89524-250
Laminate	72"	38.625"	53.5"	72"	89524-886



Motorized frame with phenolic top



Motorized frame with phenolic top

VWR® C-LEG LAB BENCHES WITH DOUBLE BAY UPRIGHTS AND TWO STEEL SHELVES

Worksurface	Width	Depth	Width, Shelves	Cat. No.
Manual				
Phenolic	60.375"	32.625"	30"	89524-252
Phenolic	60.375"	38.625"	30"	89524-888
Phenolic	72"	32.625"	36"	89524-254
Phenolic	72"	38.625"	36"	89524-890
Laminate	60.675"	32.625"	30"	89524-256
Laminate	60.675"	38.625"	30"	89524-892
Laminate	72"	32.625"	36"	89524-258
Laminate	72"	38.625"	36"	89524-894
Handcrank				
Phenolic	60.375"	32.625"	30"	89524-318
Phenolic	60.375"	38.625"	30"	89524-954
Phenolic	72"	32.625"	36"	89524-320
Phenolic	72"	38.625"	36"	89524-956
Laminate	60.375"	32.625"	30"	89524-322
Laminate	60.375"	38.625"	30"	89524-958
Laminate	72"	32.625"	36"	89524-324
Laminate	72"	38.625"	36"	89524-960
Motorized				
Phenolic	60.375"	32.625"	30"	89524-390
Phenolic	60.375"	38.625"	30"	89525-026
Phenolic	72"	32.625"	36"	89524-392
Phenolic	72"	38.625"	36"	89525-028
Laminate	60.375"	32.625"	30"	89524-394
Laminate	60.375"	38.625"	30"	89525-030
Laminate	72"	32.625"	36"	89524-396
Laminate	72"	38.625"	36"	89525-032

*Depth with uprights attached are 32.625" for 30"D tables and 38.625" for 36"D tables, due to depth of uprights and notched table top. Width dimensions shown above also include added width from uprights.

VWR® C-LEG LAB BENCHES WITH DOUBLE BAY UPRIGHTS AND FOUR STEEL SHELVES

Worksurface	Width	Depth	Steel Shelf	Cat. No.
Manual				
Phenolic	60.375"	32.625"	30"	89524-260
Phenolic	60.375"	38.625"	30"	89524-896
Phenolic	72"	32.625"	36"	89524-262
Phenolic	72"	38.625"	36"	89524-898
Laminate	60.675"	32.625"	30"	89524-264
Laminate	60.675"	38.625"	30"	89524-900
Laminate	72"	32.625"	36"	89524-266
Laminate	72"	38.625"	36"	89524-902
Handcrank				
Phenolic	60.375"	32.625"	30"	89524-326
Phenolic	60.375"	38.625"	30"	89524-962
Phenolic	72"	32.625"	36"	89524-328
Phenolic	72"	38.625"	36"	89524-964
Laminate	60.375"	32.625"	30"	89524-330
Laminate	60.375"	38.625"	30"	89524-966
Laminate	72"	32.625"	36"	89524-332
Laminate	72"	38.625"	36"	89524-968
Motorized				
Phenolic	60.375"	32.625"	30"	89524-398
Phenolic	60.375"	38.625"	30"	89525-034
Phenolic	72"	32.625"	36"	89524-400
Phenolic	72"	38.625"	36"	89525-036
Laminate	60.375"	32.625"	30"	89524-402
Laminate	60.375"	38.625"	30"	89525-038
Laminate	72"	32.625"	36"	89524-404
Laminate	72"	38.625"	36"	89525-040

*Depth with uprights attached are 32.625" for 30"D tables and 38.625" for 36"D tables, due to depth of uprights and notched table top. Width dimensions shown above also include added width from uprights.

**NEW
HEAVY-DUTY
LINE**

VWR® 4-LEG LAB BENCHES

- Heavy-duty steel structure supports loads up to 2000 lbs.
- A cost-effective option
- Easy to equip with a variety of accessories
- Manually height adjustable from 27.56" to 40.55"
- Frames are of epoxy powder-coated steel in light neutral
- Upright tubes allow for attachment of a wide range of accessories
- Worksurfaces included (unless otherwise stated)

Paint color: light neutral



VWR® 4-LEG LAB BENCHES, BASIC

Worksurface	Size, D x W, in.	Height, in.	Cat. No.
None	30 x 48	27.56 - 40.55	76355-552
None	30 x 60	27.56 - 40.55	76355-554
None	30 x 72	27.56 - 40.55	76355-556
Phenolic	30 x 48	27.56 - 40.55	76355-568
Phenolic	30 x 60	27.56 - 40.55	76355-570
Phenolic	30 x 72	27.56 - 40.55	76355-572
Laminate	30 x 48	27.56 - 40.55	76355-574
Laminate	30 x 60	27.56 - 40.55	76355-576
Laminate	30 x 72	27.56 - 40.55	76355-578

VWR® FRAME WITH NOTCHED WORKSURFACE

Worksurface	Size, D x W, in.*	Upright Type	Cat. No.
Phenolic	32.625 x 48.5	Single Bay	76355-640
Phenolic	32.625 x 60.375	Single Bay	76355-642
Phenolic	32.625 x 72.375	Single Bay	76355-644
Laminate	32.625 x 48.5	Single Bay	76355-646
Laminate	32.625 x 60.375	Single Bay	76355-648
Laminate	32.625 x 72.375	Single Bay	76355-650
Phenolic	32.625 x 60.375	Double Bay	76355-652
Phenolic	32.625 x 72.375	Double Bay	76355-654
Laminate	32.625 x 60.375	Double Bay	76355-656
Laminate	32.625 x 72.375	Double Bay	76355-658

*Notched work surfaces add 2.625" to depth of table frame. Work surfaces for single bay uprights include two notches (left and right), work surfaces for double bay uprights include three notches (left, center, right).



VWR® FRAME + TOP + SINGLE BAY UPRIGHTS

Worksurface	Size, D x W, in.*	Upright, Height 53.5 in.	Cat. No.
Phenolic	32.625 x 48.5	Single Bay	76355-580
Phenolic	32.625 x 60.375	Single Bay	76355-582
Phenolic	32.625 x 72.375	Single Bay	76355-584
Laminate	32.625 x 48.5	Single Bay	76355-586
Laminate	32.625 x 60.375	Single Bay	76355-588
Laminate	32.625 x 72.375	Single Bay	76355-590

*Depth with uprights attached are 32.625" for 30"D tables (due to depth of uprights and notched table top). Width dimensions shown above also include added width from uprights.

VWR® FRAME + TOP + DOUBLE BAY UPRIGHTS

Worksurface	Size, D x W, in.*	Upright, Height 53.5 in.	Cat. No.
Phenolic	32.625 x 60.375	Double Bay	76355-592
Phenolic	32.625 x 72.375	Double Bay	76355-594
Laminate	32.625 x 60.375	Double Bay	76355-596
Laminate	32.625 x 72.375	Double Bay	76355-598

*Depth with uprights attached are 32.625" for 30"D tables (due to depth of uprights and notched table top). Width dimensions shown above also include added width from uprights.



VWR® FRAME + TOP + SINGLE BAY UPRIGHT + ONE 11.81\"/>

Worksurface	Size, D x W, in.*	Upright, Height 53.5 in.	No. Steel Shelves (Width, in.)	Cat. No.
Phenolic	32.625 x 48.5	Single Bay	1 (48)	76355-600
Phenolic	32.625 x 60.375	Single Bay	1 (60)	76355-602
Phenolic	32.625 x 72.375	Single Bay	1 (72)	76355-604
Laminate	32.625 x 48.5	Single Bay	1 (48)	76355-606
Laminate	32.625 x 60.375	Single Bay	1 (60)	76355-608
Laminate	32.625 x 72.375	Single Bay	1 (72)	76355-610

*Depth with uprights attached are 32.625\"/>



VWR® FRAME + TOP + SINGLE BAY UPRIGHT + TWO 11.81\"/>

Worksurface	Size, D x W, in.*	Upright, Height 53.5 in.	No. Steel Shelves (Width, in.)	Cat. No.
Phenolic	32.625 x 48.5	Single Bay	2 (48)	76355-612
Phenolic	32.625 x 60.375	Single Bay	2 (60)	76355-614
Phenolic	32.625 x 72.375	Single Bay	2 (72)	76355-616
Laminate	32.625 x 48.5	Single Bay	2 (48)	76355-618
Laminate	32.625 x 60.375	Single Bay	2 (60)	76355-620
Laminate	32.625 x 72.375	Single Bay	2 (72)	76355-622

*Depth with uprights attached are 32.625\"/>



VWR® FRAME + TOP + DOUBLE BAY UPRIGHTS + TWO 11.81\"/>

Worksurface	Size, D x W, in.*	Upright, Height 53.5 in.	No. Steel Shelves (Width, in.)	Cat. No.
Phenolic	32.625 x 60.375	Double Bay	2 (30)	76355-624
Phenolic	32.625 x 72.375	Double Bay	2 (36)	76355-626
Laminate	32.625 x 60.375	Double Bay	2 (30)	76355-628
Laminate	32.625 x 72.375	Double Bay	2 (36)	76355-630

*Depth with uprights attached are 32.625\"/>



VWR® FRAME + TOP + DOUBLE BAY UPRIGHTS + FOUR 11.81\"/>

Worksurface	Size, D x W, in.*	Upright, Height 53.5 in.	No. Steel Shelves (Width, in.)	Cat. No.
Phenolic	32.625 x 60.375	Double Bay	4 (30)	76355-632
Phenolic	32.625 x 72.375	Double Bay	4 (36)	76355-634
Laminate	32.625 x 60.375	Double Bay	4 (30)	76355-636
Laminate	32.625 x 72.375	Double Bay	4 (36)	76355-638

*Depth with uprights attached are 32.625\"/>

VWR® Concept Carts

The VWR Concept Cart is a steel-framed additional worksurface with height adjustment, suitable for many uses. The integrated bottom shelf offers much needed extra storage space and an additional shelf is available as an accessory. Easy and effortless to move around or lock firmly in place by utilizing the castors with brakes. Well suited for use with all the workbenches.

- Powder-coated steel frame, painted light neutral
- Max load 330 lbs.
- Phenolic top included
- Integrated bottom steel shelf
- Height adjustable 25.6"-35.4" with an Allen key
- Four swivel casters (Ø 3.94"), two with brakes
- Additional middle steel shelf available – ordered separately (max load 55lbs.)

Move around as needed; Castors with brakes allow cart to stay firmly in place

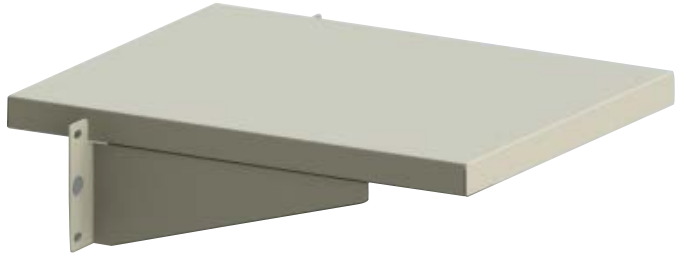

Description	Size, W x D	Cat. No.
Concept Cart with Phenolic Top	19.7" x 27.6"	76383-288
Concept Cart Middle Steel Shelf	15.75" x 19.7"	76383-290



UPRIGHT COMPONENT PARTS

Description	Cat. No.
Single Slotted Upright, 53"	10486-496
Single Slotted Upright, 63"	10486-498
30"W Horizontal Tube	10486-500
36"W Horizontal Tube	10486-502
48"W Horizontal Tube	10486-504
60"W Horizontal Tube	10486-506
72"W Horizontal Tube	10486-508
Corner Bracket Pair for Upright Modules	10486-510
Straight/Tee Bracket for Upright Modules	10486-512

UPRIGHT MODULES

Description	Cat. No.
Single Bay	
53"H for 48" Workstation	10496-572
62.3"H for 48" Workstation	10486-478
53.5"H for 60" Workstation	10486-480
62.3"H for 60" Workstation	10486-482
53.5"H for 72" Workstation	10486-484
62.3"H for 72" Workstation	10486-486
Double Bay	
53.5"H for 60" Workstation	10486-488
62.3"H for 60" Workstation	10486-490
53.5"H for 72" Workstation	10486-492
62.3"H for 72" Workstation	10486-494

Usable height of uprights = 42.3"/51.18" from top. See page 19 for product specifications.

COUNTER-MOUNTED UPRIGHTS ONLY

Upright Height	Mounting	Cat. No.
31.10"	Left/Right	10808-826
31.10"	Center	10808-828
39.37"	Left/Right	10808-830
39.37"	Center	10808-832
47.24"	Left/Right	10808-834
47.24"	Center	10808-836

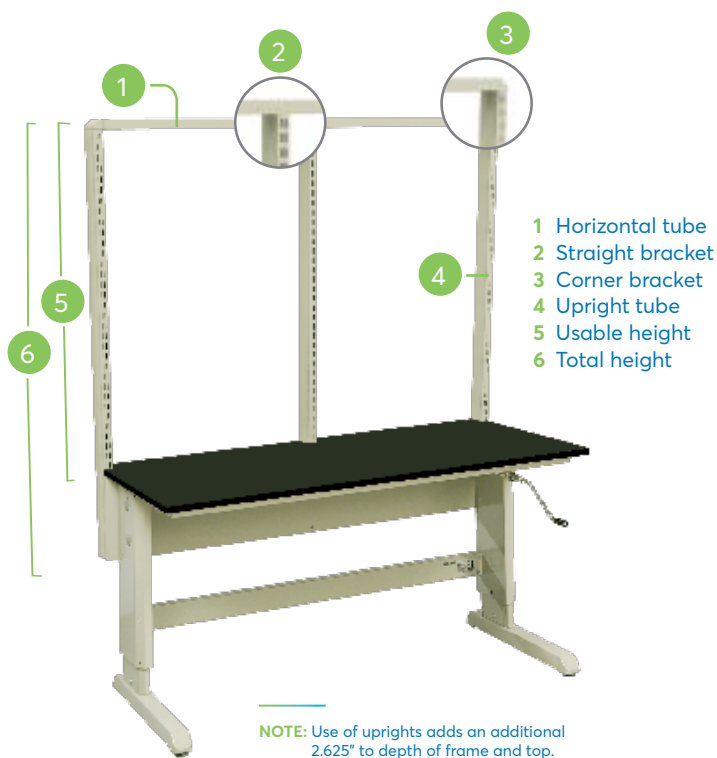

REAGENT RACK COUNTER MOUNTED SHELVING

The shelf bay includes two left/right uprights with brackets, one horizontal rail, and two corner brackets. The shelf bay extension includes one center upright with brackets and one horizontal rail.

Width	Cat. No.
Shelf Bay 31.10"	
30"	10808-838
36"	10808-850
48"	10808-862
60"	10808-874
72"	10808-886
Shelf Bay 39.37"	
30"	10808-842
36"	10808-854
48"	10808-866
60"	10808-878
72"	10808-890
Shelf Bay 47.24"	
30"	10808-846
36"	10808-858
48"	10808-870
60"	10808-882
72"	10808-894

Width	Cat. No.
Shelf Extension 31.10"	
30"	10808-840
36"	10808-852
48"	10808-864
60"	10808-876
72"	10808-888
Shelf Extension 39.37"	
30"	10808-844
36"	10808-856
48"	10808-868
60"	10808-880
72"	10808-892
Shelf Extension 47.24"	
30"	10808-848
36"	10808-860
48"	10808-872
60"	10808-884
72"	10808-896

Load capacity 310 lbs. per bay.
Shelves not included, more information on page 13. See page 20 for mounting hole locations.



VWR® WALL SHELVING SYSTEM

Ideal for storing items in spaces where order is paramount, reusable system can be dismantled and reinstalled with minimal effort. Powder-coated steel finish.

Horizontal rails include hole plugs and end caps. Select VWR Lab Bench slotted upright accessories – steel shelves, (including lips and bookend brackets), upright cabinets and bin rails, are compatible with the VWR Wall Shelving System.

Description	Size	Cat. No.
Oval Horizontal Rail	48"	75795-940
Oval Horizontal Rail	96"	75795-938
Upright Tube	47.24"	75795-956
Upright Tube	78.74"	75795-958

Weight capacity: 600 lbs per 40" module
Shelves not included, more information on page 13.





CASTERS

Description	Cat. No.
(1) Caster Set* 3.93" Diameter (adds 5.5")	89524-478
(2) Low Profile Caster Set*	89524-480
(3) Roll & Set Caster Set - 2.75"H (adds 3.5")	89524-482
(4) Transport Skate **	89524-484

* Set includes two locking and two non-locking casters
 ** Adds 1.5" to table height when in use

TRANSPORT SKATE

With a transport skate, one person can easily move benches. For long-distance moving, you will need two transport skates.



Tilttable steel shelf w/ standard bracket (included)



Shelf lips

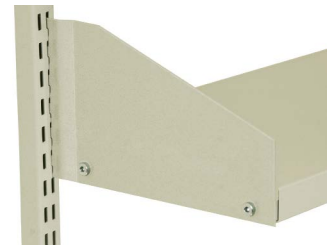

Bookend brackets

TILTTABLE EQUIPMENT SHELVES

Dimensions	Cat. No.
30 x 11.81"	76355-532
30 x 15.75"	76355-534
36 x 11.81"	76355-536
36 x 15.75"	76355-538
48 x 11.81"	76355-540
48 x 15.75"	76355-542
60 x 11.81"	76355-544
60 x 15.75"	76355-546
72 x 11.81"	76355-548
72 x 15.75"	76355-550

SHELF LIPS

Description	Cat. No.
30" Shelf Lip, Edge 1.5"	89524-510
36" Shelf Lip, Edge 1.5"	89524-512
48" Shelf Lip, Edge 1.5"	89524-514
60" Shelf Lip, Edge 1.5"	89524-516
72" Shelf Lip, Edge 1.5"	89524-518
30" Shelf Lip, Edge 3"	76355-660
36" Shelf Lip, Edge 3"	76355-662
48" Shelf Lip, Edge 3"	76355-664
60" Shelf Lip, Edge 3"	76355-666
72" Shelf Lip, Edge 3"	76355-668

BOOKEND BRACKETS

Description	Cat. No.
11.81" Bookend Bracket	89524-506
15.74" Bookend Bracket	89524-508

VWR® USU utility support uprights

Adjustable cable channels can be configured to suit a range of power, gas, and data needs, while also providing shelving storage above the worksurface. They are attached directly to a top and allow for easy access to utilities without reducing the usable work surface area. Cable channels hide cords and hoses, creating a clean work space. Services can be connected via overhead service carriers, or from underneath the surface through the mounting bracket.

Paint color: light neutral



SINGLE BAY USU UTILITY SUPPORT UPRIGHT KITS

Description	Height	Width	Depth	Cat. No.
M48 Single Bay USU Counter Mounted Kit	45.18"	50.31"	9.65"	76308-838
M60 Single Bay USU Counter Mounted Kit	45.18"	62.13"	9.65"	76308-840
M72 Single Bay USU Counter Mounted Kit	45.18"	74.06"	9.65"	76308-842

BRACKETS FOR SINGLE BAY KITS

Description	Cat. No.
Bookend Bracket for 12"D Shelf	76383-284
Bookend Bracket for 16"D Shelf	76383-286

HORIZONTAL UTILITY CHANNELS FOR SINGLE BAY KITS

Description	Cat. No.
M48 Horizontal Utility Channel For USU	76308-866
M60 Horizontal Utility Channel For USU	76308-868
M72 Horizontal Utility Channel For USU	76308-870

SERVICE PANELS FOR HORIZONTAL CHANNELS

Description	Cat. No.
Front Horizontal Panel M1200 3-Hole	76308-872
Front Horizontal Panel M1200 4-Hole	76308-874
Front Horizontal Panel M1200 5-Hole	76308-876
Front Horizontal Panel M1500 3-Hole	76308-878
Front Horizontal Panel M1500 4-Hole	76308-880
Front Horizontal Panel M1500 5-Hole	76308-882
Front Horizontal Panel M1800 3-Hole	76308-884
Front Horizontal Panel M1800 4-Hole	76308-928
Front Horizontal Panel M1800 5-Hole	76308-930

MIDDLE DIVIDER AND SHELVES FOR USU DOUBLE BAY

Description	Cat. No.
Middle Vertical Divider	76308-864
Shelf with Lip, 30W" x 11.81D"	76355-532
Shelf with Lip, 30W" x 15.75D"	76355-534
Shelf with Lip, 36W" x 11.81D"	76355-536
Shelf with Lip, 36W" x 15.75D"	76355-538

SERVICE PANELS WITH CUT OUTS FOR USU VERTICAL UPRIGHTS

Description	Cat. No.
Service Panel (1 Pc.), in Upright, Three 1" Holes	76308-934
Service Panel (1 Pc.), in Upright, Cutout for One Decora Duplex.	76308-936
Service Panel (1 Pc.), in Upright, Cutout for Two Decora Duplex.	76308-938
Service Panel (1 Pc.), in Upright, Cutout for Two Decora Duplex + One Data Duplex Receptacle	76308-940

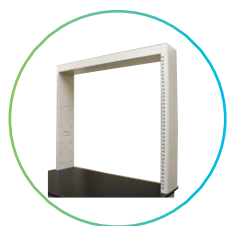

Single bay USU utility support upright kits



Brackets and shelves for single bay kits

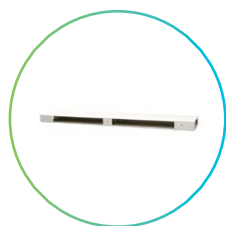

Horizontal utility channels for single bay kits



Service panels for horizontal channels

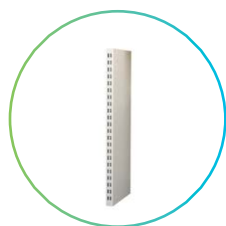

Middle divider and shelves for USU double bay



Service panels with cut outs for USU vertical uprights



Magnetic mounting attachment under metal shelves



High/Low/Off switch allows for varying light intensity



Vertical power rail



Horizontal power rail

LED LIGHTING

Description	Size	Power	Cat. No.
24" Dual LED Light with Shield, Magnetic Attachment	22.44" x 1.26" x 1.81"	1200Lm5000K	76319-838
36" Dual LED Light with Shield, Magnetic Attachment	33.46" x 1.26" x 1.81"	1800Lm5000K	76319-840
48" Dual LED Light with Shield, Magnetic Attachment	44.48" x 1.26" x 1.81"	2400Lm5000K	76319-842
Extension Cable, 12"	12"L	-	89524-526
Extension Cable, 36"	36"L	-	89524-528

HOLDERS

Description	Size	Max lbs.	Cat. No.
Equipment Holder - C-leg Bar Mount	3.94" x 19.68" x 3.35"	44	89524-550
Equipment Holder - C-leg Leg Mount	3.94"-9.49" x 17.71" x 1.96"	44	89524-552
Equipment Holder - C-leg Motor Leg Mount	3.94"-9.49" x 17.71" x 1.96"	44	89524-554
Equipment Holder - Four-leg	3.94"-9.49" x 17.71" x 1.96"	44	10746-456
LCD Holder with Double Arm, VESA 75/100 (A)	—	33	89524-560
Keyboard Tray for LCD Holder (B)	18.89" x 10.23"	11	89524-562
Keyboard and Mouse Tray for LCD Holder (C)	24.40" x 10.23"	11	89524-564
Height Adjustable Arm with Bracket (D)	—	33	89524-566
Bag Holder for Bench Top Lower Edge (E)	—	—	89524-614
Bottle Holder (3.14" base) (F)	—	—	89524-616
Roll Holder for Upright (Roll ø Height 5.90 inches, Width 6.88 inches) (G)	—	—	89524-618

POWER RAILS

Description	Cat. No.
30" Bin Rail w/6 Outlet Power	10611-600
30" Bin Rail w/6 Outlet Power, Surge	10611-602
36" Bin Rail w/6 Outlet Power	10611-604
36" Bin Rail w/6 Outlet Power, Surge	10611-606
48" Bin Rail w/6 Outlet Power	89524-530
48" Bin Rail w/6 Outlet Power, Surge	89524-532
60" Bin Rail w/6 Outlet Power	89524-534
60" Bin Rail w/6 Outlet Power, Surge	89524-536
72" Bin Rail w/6 Outlet Power	89524-538
72" Bin Rail w/6 Outlet Power, Surge	89524-540
6 Outlet Vertical Power Bar with Clamp*	89524-542
6 Outlet Vertical Power Bar with Clamp, Surge*	89524-544
12 Outlet Vertical Power Bar with Clamp*	89524-546
12 Outlet Vertical Power Bar with Clamp, Surge*	89524-548

*Can also be mounted underneath the worksurface

NOTE: All VWR bench accessories with painted steel components match light neutral frame color.

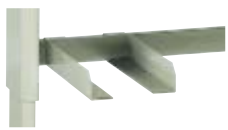

Equipment holder - C-leg (bar)



Equipment holder - four-leg

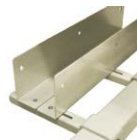

Equipment holder - C-leg



(A) LCD holder with double arm



(B/C) Keyboard tray for LCD holder



(D) Height adjustable LCD monitor arm



(E) Bag holder



(F) Bottle holder



(G) Roll Holder



Bin rail with brackets. Bins sold separately.

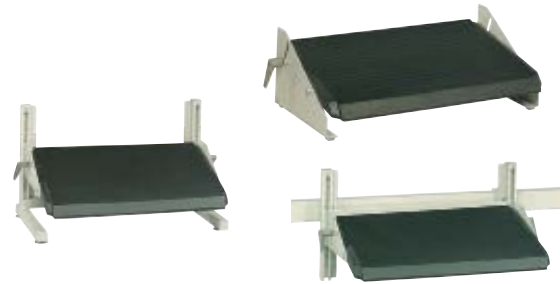

BIN RAILS

Description	Size	Description	Cat. No.
30" Bin Rail	29.21" x 3.54"		89524-568
36" Bin Rail	35.23 x 3.54"		89524-570
48" Bin Rail	47.04 x 3.54"		89524-572
60" Bin Rail	58.89 x 3.54"		89524-574
72" Bin Rail	70.66 x 3.54"		89524-576

Bin rail load capacity 110 lbs per rail
 Bins rails may be mounted straight or angled at 15°

FOOTRESTS

Description	Size	Cat. No.
Footrest, Floor (5-30° tilt)	21.65" x 13.77" x 8.66"	89524-578
Footrest, Floor Height Adjustable (5-30° tilt)	21.65" x 13.77" x 3.54 to 11.02"	89524-580
Footrest, Bar Attachment (5-30° tilt)	21.65" x 13.77" x 3.54 to 11.02"	89524-582



BENCH DRAWERS

Description	Size	Max lbs	Cat. No.
Bench Drawer Unit 30/ 15 w/ 1 - 3.94" Drawer	11.81" x 17.20" x 5.91"	22 lbs/drawer	89524-600
Bench Drawer Unit 30/ 22 w/ 2 - 3.94" Drawers	11.81" x 17.20" x 8.74"	22 lbs/drawer	89524-602
Bench Drawer Unit 38 w/ 2 - 100% Extendable Drawers	14.96" x 20.47" x 10.23"	132 lbs/drawer	89524-604



BENCH DRAWER ATTACHMENT BRACKETS

Description	Cat. No.
Drawer Attachment Bracket for 30"D x 48"W Manual C-leg Bench	10820-620
Drawer Attachment Bracket for 30"D x 60"W Manual C-leg Bench	10820-622
Drawer Attachment Bracket for 30"D x 72"W Manual C-leg Bench	10820-624
Drawer Attachment Bracket for 36"D Manual/Handcrank C-leg Bench	10746-454
Drawer Attachment Bracket for 30"/ 36"D Motorized C-leg Bench	89524-610
Drawer Mounting Bracket for 30x48 Four-leg Bench	10611-638
Drawer Mounting Bracket for 30x60 Four-leg Bench	10611-640



NOTE: When adding cabinets, consider under surface dimensions, found on product specifications pages 18-20.

VWR® CONTOUR HANGING CABINETS

Description	Dimensions, W x D x H	Cat. No.
3 Drawer w/Pull Board	18" x 22" x 19"	CFD-5002-B
Base Unit 1 Door w/Pull Board	18" x 22" x 19"	CFC-5032-B
1 Door LEFT Hinge w/Pull Board	18" x 22" x 19"	CFC-5032-BL
2 Drawer 1 File Drawer w/Pull Board	18" x 22" x 19"	CFD-5852-B
3 Drawer	18" x 22" x 25"	CFD-4002-A
3 Drawer w/Pull Board	18" x 22" x 25"	CFD-4002-B
1 Door Right Hinge	18" x 22" x 25"	CFC-4032-A
Base Unit 1 Door w/Pull Board	18" x 22" x 25"	CFC-4032-B
1 Door LEFT Hinge w/Pull Board	18" x 22" x 25"	CFC-4032-BL
1 Door 1 Drawer	18" x 22" x 25"	CFE-4402-A
1 Door 1 Drawer Left Hinge	18" x 22" x 25"	CFE-4402-L
1 Door 1 Drawer w/Pull Board	18" x 22" x 25"	CFE-4402-B
Base Unit 1 Door LEFT Hinge 1 Drawer w/Pull Board	18" x 22" x 25"	CFE-4402-BL
2 File Drawer w/Hangers	18" x 22" x 25"	CFD-4812-A
2 Drawer 1 File Drawer w/Pull Board	18" x 22" x 25"	CFD-4852-B

CONTOUR CABINET ATTACHMENT BRACKETS

Description	Cat. No.
Bracket for C-leg Manual 30x48, 36x48	10611-644
Bracket for C-leg Manual 30x60, 36x60	10611-646
Bracket for C-leg Manual 30x72, 36x72	10611-648
Bracket for C-leg Motor 30x48, 36x48	10611-650
Bracket for C-leg Motor 30x60, 36x60	10611-652
Bracket for C-leg Motor 30x72, 36x72	10611-654
Drawer Mounting Bracket for 30x48 Four-leg Bench	10611-638
Drawer Mounting Bracket for 30x60 Four-leg Bench	10611-640

Contour™ cabinets are not able to attach to C-leg Handcrank frames.



Sliding door cabinet



Overhead flipper door cabinet



Binder box

CABINETS

Description	Size	Max lbs	Cat. No.
30" Sliding Door Cabinet	28.34" x 14.56" x 15.74"	88	89524-594
Divider for Sliding Door Cabinet	9.84" x 7.87"	—	89524-590
CD/Folder Box, Attached to Upright Tube	5.11" x 11.41" x 12.99"	11	89524-592
30" Overhead "Flipper Door" Cabinet	29.25" x 13" x 15.68"	88	89524-606
36" Overhead "Flipper Door" Cabinet	35.37" x 13" x 15.68"	88	89524-596
Divider for Overhead "Flipper Door" Cabinet	11.80" x 10.40"	—	89524-598

VWR® Worktable frames

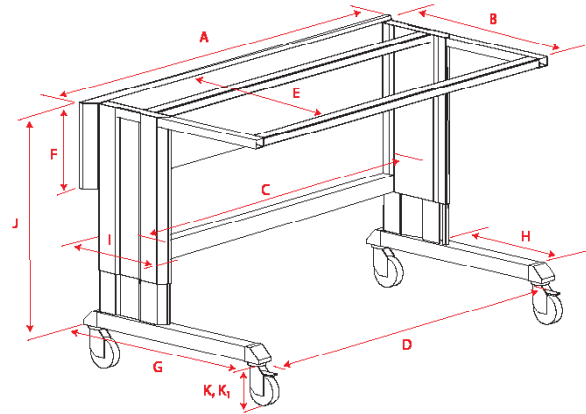

WORKTABLE FRAMES

- VWR® Worktable Frame consists of a pair of legs, rear case, and front rail
- VWR Frames are available in depths: 30" and 36"
- VWR Frames are available in widths: 48", 60", and 72"
- Table frames can be easily equipped with any 12mm stem caster

Steel Thickness:

- Steels used in the construction of the frames are 12, 14, and 16 gauge CRS steel, except as follows:
 - Leg attachment parts: 7 gauge CRS steel
 - Cable rail: 20 gauge CRS steel

Tools needed for C-leg frame assembly:

- 19mm wrench
- 13mm wrench
- 5mm Allen wrench
- #2 Phillips head screwdriver

Tools needed for assembly:

- 10mm wrench
- 8mm Allen wrench

Recommended table top assembly:

- VWR® Laminate Tops assembled with wood screws provided
- VWR® Phenolic Tops can be assembled in two ways:
 - Mechanical fasteners (screws) - Pre-drill a pilot hole in the bottom of the work surface, taking care to keep from penetrating through the top. The pre-drilled hole should be the same length as the screw shaft. The screw should be slightly larger in diameter than the pilot hole. Use a coarse threaded screw, wood or machine. (Important: do not use provided screws for phenolic tops)
 - Adhesive - Use 100% silicon. Apply several "spots" or a continuous bead to the top of the table frame. Position the work surface as centered on the frame and let cure for 12 hours at room temperature.

C-LEG MANUAL

- Leg pair can support 1100 lb load, evenly loaded.
- Height adjustment of VWR® Worktable Frame is 26.62" to 44.34" with table top (3/4") and adjustment glide. Height adjustment is made by adjusting telescoping legs and tightening friction screws on the back and sides of the legs.

	30" x 48"	36" x 48"	30" x 60"	36" x 60"	30" x 72"	36" x 72"
A	47.24"	47.24"	59.06"	59.06"	70.86"	70.86"
B	29.07"	35.09"	29.07"	35.09"	29.07"	35.09"
C	40.78"	40.78"	52.60"	52.60"	64.41"	64.41"
D	40.11"	40.11"	51.93"	51.93"	63.74"	63.74"
E	22.93"	28.88"	22.93"	28.88"	22.93"	28.88"
F	11.43"	11.43"	11.43"	11.43"	11.43"	11.43"
G	29.52"	29.52"	29.52"	29.52"	29.52"	29.52"
H	17.57"	17.57"	17.57"	17.57"	17.57"	17.57"
I	11.12"	11.12"	11.12"	11.12"	11.12"	11.12"
J	26.82- 44.34"	26.82- 44.34"	26.82- 44.34"	26.82- 44.34"	26.82- 44.34"	26.82- 44.34"
K	5.5"	5.5"	5.5"	5.5"	5.5"	5.5"
*K ₁	2.87"	2.87"	2.87"	2.87"	2.87"	2.87"

*K₁ - low profile caster option

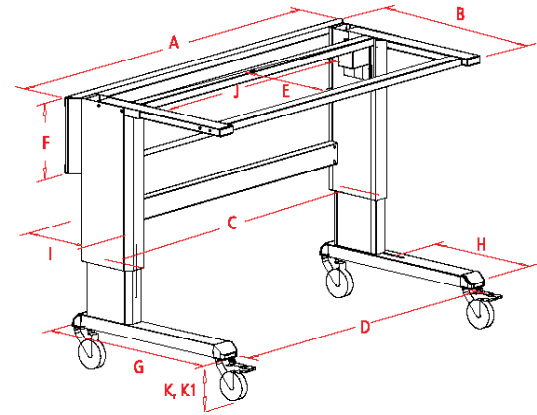
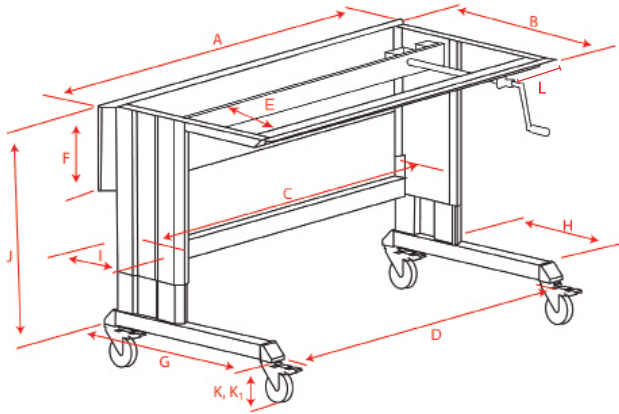

C-LEG HANDCRANK

- Pair of legs of crank frame can support 440 lbs dynamic load, and 1100 lbs static load, evenly loaded
- VWR® Frames are available in depths: 30" and 36"
- VWR Frames are available in widths: 48", 60", and 72"
- Height adjustment of crank frame is 27.4" to 41.2" with table top (3/4")
- The crank handle can be installed on the left or right side of the frame. Standard table configuration is right-hand crank.
- Height adjustment change one inch per each full rotation of the crank handle
- The crank folds away under the frame when not in use

C-LEG MOTORIZED

- Leg pair of VWR® Motorized Frame can support a static load of 1100 lbs, evenly loaded on a worktop and a dynamic load of 880 lbs, evenly loaded
- VWR® Frames are available in depths: 30" and 36"
- VWR Frames are available in widths: 48", 60", and 72"
- Height adjustment range of VWR Motorized Frame is 27.80" to 43.55" with table top (3/4") and adjustment glides. Adjustment is made with 2 linear actuators, using an up/down memory desk switch.
- The speed of the frame is .70" / sec without load
- The speed of the frame is .59" / sec with load
- The desk switch can be installed on the front, left, or right side of frame
- The desk switch has multi-position memory system to be able to set the frame to three customer-based heights and up/down buttons for random settings
- All units have soft-start and soft-stop circuitry
- The table can be manually driven over the memory positions
- Silent operation; 45 dB (A) DS/EN ISO 3746
- Capable of operations in ambient temperature 41 to 104°F

	30" x 48"	36" x 48"	30" x 60"	36" x 60"	30" x 72"	36" x 72"
A	47.24"	47.24"	59.06"	59.06"	70.86"	70.86"
B	29.07"	35.09"	29.07"	35.09"	29.07"	35.09"
C	40.78"	40.78"	52.60"	52.60"	64.41"	64.41"
D	40.11"	40.11"	51.93"	51.93"	63.74"	63.74"
E	16.44"	16.44"	16.44"	16.44"	16.44"	16.44"
F	11.43"	11.43"	11.43"	11.43"	11.43"	11.43"
G	29.52"	29.52"	29.52"	29.52"	29.52"	29.52"
H	18.28"	18.28"	18.28"	18.28"	18.28"	18.28"
I	9.26"	9.26"	9.26"	9.26"	9.26"	9.26"
J	26.82-40.60"	26.82-40.60"	26.82-40.60"	26.82-40.60"	26.82-40.60"	26.82-40.60"
K	5.5"	5.5"	5.5"	5.5"	5.5"	5.5"
*K ₁	2.87"	2.87"	2.87"	2.87"	2.87"	2.87"
L	8.06"	8.06"	8.06"	8.06"	8.06"	8.06"

*K₁ - low profile caster option

	30" x 48"	36" x 48"	30" x 60"	36" x 60"	30" x 72"	36" x 72"
A	47.24"	47.24"	59.06"	59.06"	70.86"	70.86"
B	29.07"	34.57"	29.07"	34.57"	29.07"	34.57"
C	38.12"	38.12"	49.94"	49.94"	61.75"	61.75"
D	40.11"	40.11"	51.93"	51.93"	63.74"	63.74"
E	14.88"	14.88"	14.88"	14.88"	14.88"	14.88"
F	11.43"	11.43"	11.43"	11.43"	11.43"	11.43"
G	29.52"	29.52"	29.52"	29.52"	29.52"	29.52"
H	18.28"	18.28"	18.28"	18.28"	18.28"	18.28"
I	9.26"	9.26"	9.26"	9.26"	9.26"	9.26"
J	31"	31"	43.53"	43.53"	55.33"	55.33"
K	5.5"	5.5"	5.5"	5.5"	5.5"	5.5"
*K ₁	2.87"	2.87"	2.87"	2.87"	2.87"	2.87"

*K₁ - low profile caster option

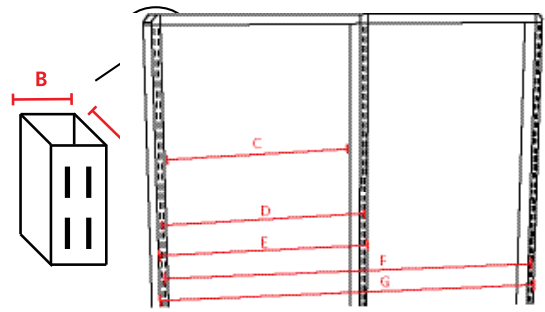
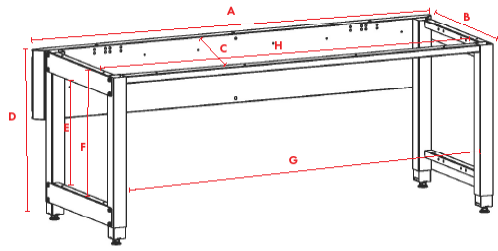

4-LEGGED BENCH

- Front and rear components come welded to the legs, saving install time and increasing strength
- Frames are available in 30" depth
- Frames are available in widths: 48", 60", and 72"
- Table frames can be easily equipped with any 12mm stem caster
- Weight capacity: 2000 lbs.

STEEL THICKNESS:

Steel used in the construction of the frames are 12, 14, and 16 gauge CRS steel, except as follows:

- Leg attachment parts: 7 gauge CRS steel
- Cable rail: 20 gauge CRS steel

SLOTTED UPRIGHTS

- Uprights are available in heights: 53.5" and 62.3" (usable height above the work surface is 42.3" and 51.18")
- Depth of the uprights is 2.36"
- Width of the uprights is 1.18"
- Uprights can be attached to each table frame to enable the use of accessories
- Upright module consists of a minimum of 2 uprights, which are installed with the correct spacing for the desired module size (see table)
- Upright modules can easily be extended to create double modules (3 uprights needed)
- Each upright can support loads equal to the maximum load limited by table frame or accessories in use
- For accessories the height adjustment steps are 1.1"
- Steel thickness: Steel used in the construction of the upright is 14 gauge CRS steel in light neutral

	30" x 48"	30" x 60"	30" x 72"
A	47.24"	59.06"	71.10"
B	27.81"	27.81"	27.81"
C	23.62"	23.62"	23.62"
D	27.56"-40.55"	27.56"-40.55"	27.56"-40.55"
E	18.11"	18.11"	18.11"
F	21.46"	21.46"	21.46"
G	29.37"	51.18"	62.99"
H	41.93"	53.74"	65.55"

	2.36"	2.36"	2.36"	2.36"	2.36"
A	2.36"	2.36"	2.36"	2.36"	2.36"
B	1.18"	1.18"	1.18"	1.18"	1.18"
C	46.06"	57.87"	69.92"	28.35"	34.37"
D	47.2"	59.1"	71.1"	19.7"	19.7"
E	48.42"	60.23"	72.28"	20.86"	20.86"
F	—	—	—	59.06"	71.11"
G	—	—	—	60.23"	72.28"

NOTE: Use of uprights adds an additional 2.625" to depth of frame.

REAGENT RACK HOLE MOUNTING INFO

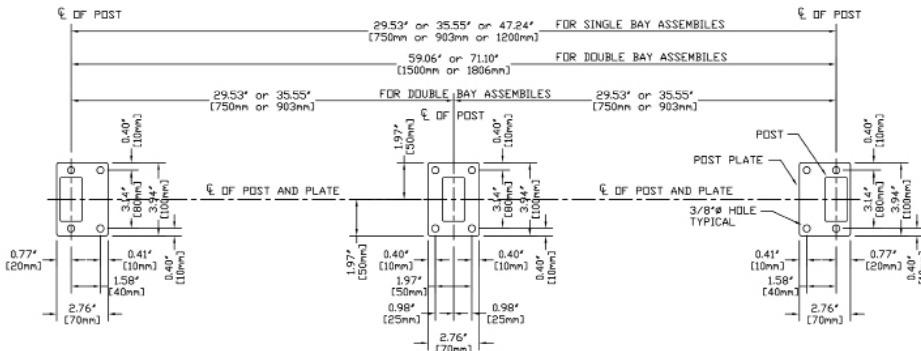

800 932 5000 | VWR.COM

Prices, product, and/or services details are current when published and subject to change without notice. | Certain products or services may be limited by federal, state, provincial, or local regulations. | VWR, part of Avantor, makes no claims or warranties concerning sustainable/green products. Any claims concerning sustainable/green products are the sole claims of the manufacturer and not those of VWR International, LLC and/or Avantor, Inc. or affiliates. All prices are in US dollars unless otherwise noted. Offers valid in US and Canada, void where prohibited by law or company policy, while supplies last. | Trademarks are owned by Avantor, Inc. or its affiliates, unless otherwise noted. | Visit vwr.com to view our privacy policy, trademark owners, and additional disclaimers. © 2020 Avantor, Inc. All rights reserved.