

Exterior

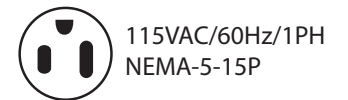
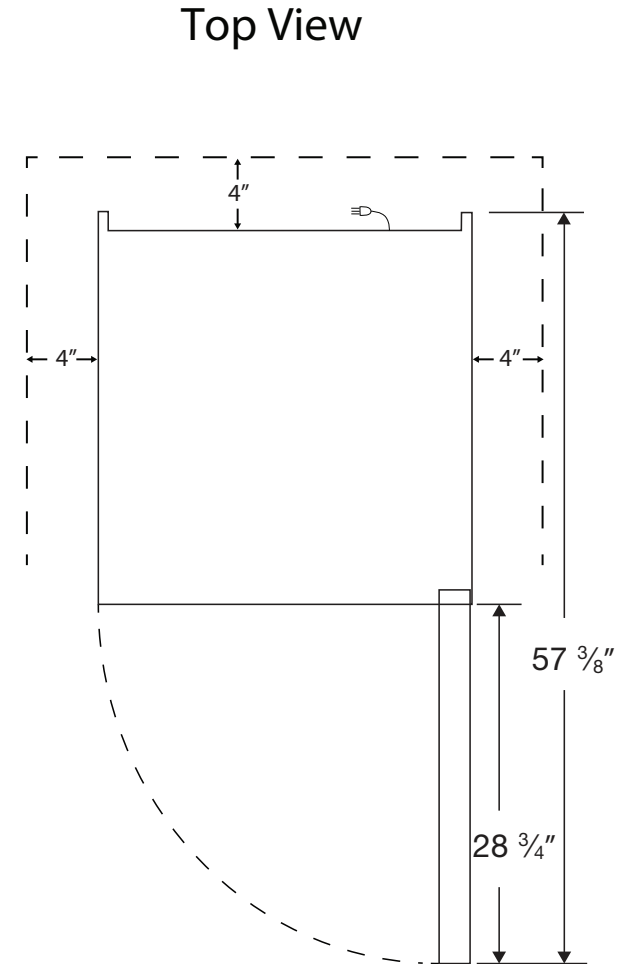
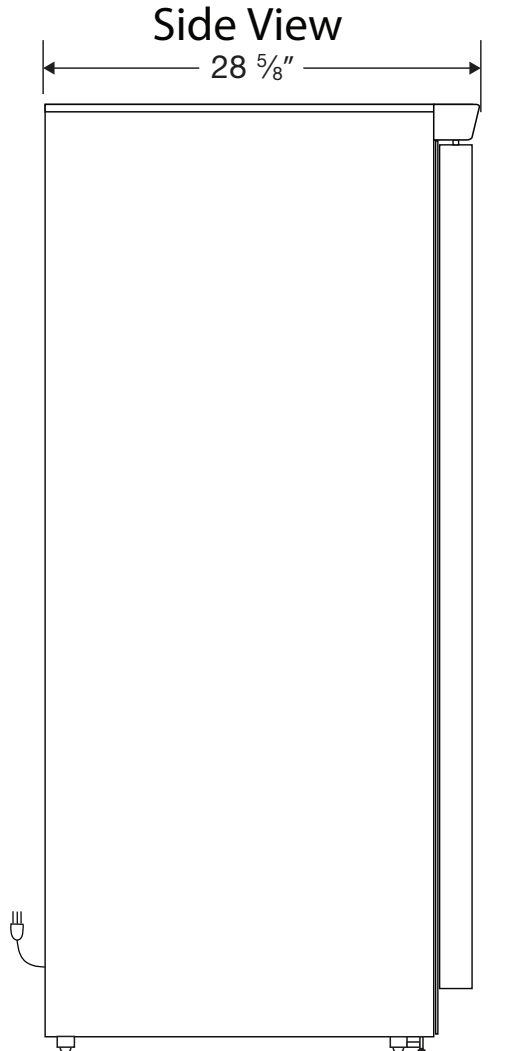
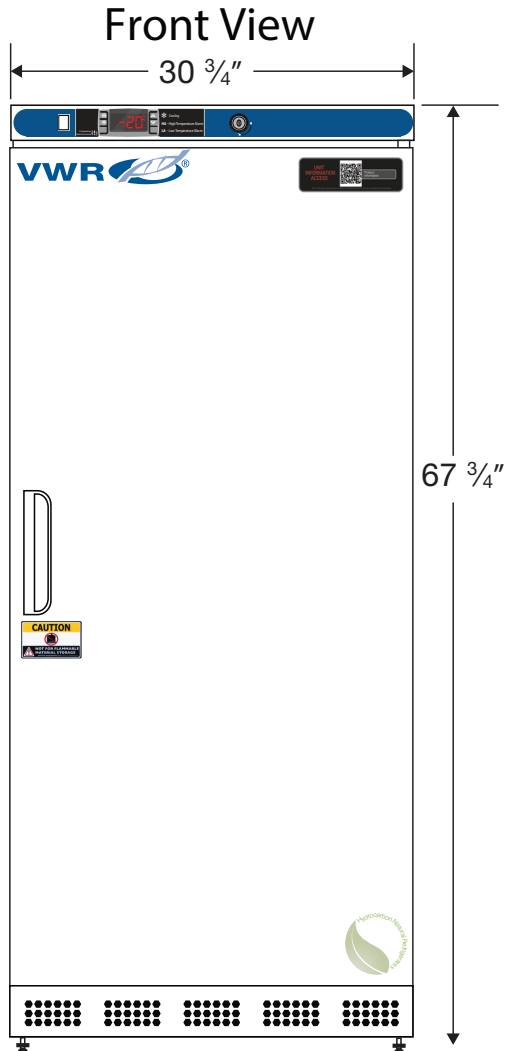

NOTE: Ventilation Requirements – Minimum 4" clearance on sides and back
Cat# 76580-172/VWR-HC-MFP-17

Cu.Ft.	Defrost	Door	Int Door	Shelves	W"	D"	H"	Refrigerant	H.P.	Amps	Weight
17	Manual	1 Solid	0	6 Fixed	30 3/4	28 5/8	67 3/4	R290	1/2	6	190 lbs.