



Instruction Manual Incubating/Cooling Shaker



TABLE OF CONTENTS

Package Contents	1
Warranty	1
Installation	2
Maintenance & Servicing	2
Environmental Conditions	2
Safety Instructions	3
Standards & Regulations	3
Control Panel	4
Specifications	5
Operating Instructions	5-8
Troubleshooting	8
Replacement Parts	9
Modular Blocks	10

PACKAGE CONTENTS

Incubating/Cooling Shaker
92" (234cm) detachable power cord
Instruction manual

WARRANTY

Manufacturer warrants this product to be free from defects in material and workmanship when used under normal conditions for five (5) years. Register your equipment or instrument online at: www.vwrsp.com/warranty for US residents and www.vwrcanlab.com/warranty for Canadian residents. For your reference, make a note of the serial number, date of purchase and supplier here.

Serial No.: _____

Date of Purchase: _____

Supplier: _____

INSTALLATION

Upon receiving the VWR Incubating/Cooling Shaker, check to ensure that no damage has occurred in shipment. It is important that any damage that occurred in transport is detected at the time of unpacking. If you do find such damage the carrier must be notified immediately.

After unpacking, place the Incubating/Cooling Shaker on a level bench or table, away from explosive vapors. Secure to a non-movable work surface by pressing down on the four (4) corners of the unit, creating a strong suction to the work surface (**DO NOT** place on a bench mat). Ensure that the surface on which the unit is placed will withstand typical heat produced by the unit. Always place the unit on a sturdy work surface.

The Incubating/Cooling Shaker is supplied with a power cord that is inserted into the IEC connector on the back of the unit first, then it can be plugged into a properly grounded outlet. The 120V unit plugs into a 120 volt, 50/60 Hz source. The 230V unit plugs into a 230 volt, 50/60 Hz source.

MAINTENANCE & SERVICING

The Incubating/Cooling Shaker is built for long, trouble-free, dependable service. No lubrication or other technical user maintenance is required. It needs no user maintenance beyond keeping the surfaces clean. The unit should be given the care normally required for any electrical appliance. Avoid wetting or unnecessary exposure to fumes. Spills should be removed promptly. **DO NOT** use a cleaning agent or solvent on the front panel or lid which is abrasive or harmful to plastics, nor one which is flammable. Avoid cleaning in direct sunlight to prevent streaking of the polycarbonate lid. Always ensure the power is disconnected from the unit prior to any cleaning. If the unit ever requires service, contact your VWR representative.

ENVIRONMENTAL CONDITIONS

Operating Conditions: Indoor use only.

Temperature: 5 to 40°C (41 to 104°F)
Humidity: 80% relative humidity, non-condensing
Altitude: 0 to 6,562 ft (2000 M) above sea level

Non-Operating Storage:

Temperature: -20 to 65°C (-4 to 149°F)
Humidity: max. 80% relative humidity, non-condensing

Installation Category II and Pollution Degree 2 in accordance with IEC 664.

SAFETY INSTRUCTIONS

Please read the entire instruction manual before operating the VWR Incubating/Cooling Shaker.



WARNING! DO NOT use the Incubating/Cooling Shaker in a hazardous atmosphere or with hazardous materials for which the unit was not designed. Also, the user should be aware that the protection provided by the equipment may be impaired if used with accessories not provided or recommended by the manufacturer, or used in a manner not specified by the manufacturer.

DO NOT lift unit by the tray or lid. Always operate unit on a level surface for best performance and maximum safety.



CAUTION! To avoid electrical shock, completely cut off power to the unit by disconnecting the power cord from the unit or unplug from the wall outlet. Disconnect unit from the power supply prior to maintenance and servicing.

Spills should be removed promptly. **DO NOT** immerse the unit for cleaning. **DO NOT** operate the unit if it shows signs of electrical or mechanical damage.



Earth Ground - Protective Conductor Terminal



Alternating Current



Pinch Point - Keep fingers clear during operation.

STANDARDS & REGULATIONS

Troemner, LLC hereby declares under its sole responsibility that the construction of this product conforms in accordance with the following standards:

Safety standards:

IEC 61010-1

Safety requirements for electrical equipment for measurement, control and laboratory use. Part I: General Requirements.

IEC 61010-2-010

Part II: Particular requirements for laboratory equipment for the heating of materials.

IEC 61010-2-051

Part II: Particular requirements for laboratory equipment for mixing and stirring.

UL Std. No. 61010-1

CSA/CAN C22.2 No. 0-M91

CSA/CAN C22.2 No. 61010-1-04

EMC standards:

EN55022-A EN45501

EN61000-3-2 EN61000-3-3

EN61000-4-2 EN61000-4-3

EN61000-4-4 EN61000-4-5

EN61000-4-6 EN61000-4-11

Associated EU guidelines:

EMC directive 2004/108/EC

LVD directive 2006/95/EC

RoHS directive 2015/863/EU

CONSIGNES DE SÉCURITÉ

Veuillez lire le manuel d'instruction dans sa totalité avant d'utiliser l'agitateur incubateur/refroidissement.



AVERTISSEMENT! NE vous servez **PAS** de l'agitateur incubateur/refroidissement dans un environnement dangereux ou avec des matériaux dangereux pour lesquels cet appareil n'a pas été conçu. D'autre part, sachez que la protection offerte par l'appareil devient obsolète si celui-ci est utilisé avec des accessoires non fournis ou recommandés par le fabricant ou s'il est utilisé de façon non appropriée.

Utilisez toujours l'appareil sur une surface de niveau pour assurer une performance optimale et une sécurité maximale.

NE soulevez **PAS** l'appareil par le plateau ou le couvercle.



AVERTISSEMENT Pour éviter tout risque d'électrocution, coupez complètement l'alimentation de l'appareil, débranchez le cordon d'alimentation de l'appareil ou de la prise murale. Débranchez l'alimentation avant toute procédure d'entretien et de dépannage.

Essayez promptement tout liquide renversé. N'immergez **PAS** l'appareil pour le nettoyer.

NE faites **PAS** fonctionner l'appareil s'il semble avoir subi des dommages électriques ou mécaniques.



AVERTISSEMENT Le témoin Caution Hot signale que la température ambiante de la chambre est supérieure à 40°C. Le témoin s'allume et reste allumé lorsque la température ambiante de la chambre atteint environ 40°C. Une fois le chauffage éteint, le témoin Caution Hot reste allumé jusqu'à ce que la température ambiante de la chambre soit inférieure à 40°C.



Terre - Borne du conducteur de protection



Courant alternatif

NORMES ET RÉGLEMENTATIONS

Par la présente, VWR International déclare sur l'honneur que les produits sont conformes aux exigences des directives et des normes suivantes.

Directives UE directive:

Directive EMC	2014/30/EU
Directive LVD	2014/35/EU
Directive ROHS	2011/65/EU
Directive ROHS	2015/863/EU
Directive WEEE	2012/19/EU

Normes de sécurité:

IEC 61010-1
EN 61010-2-010
EN 61010-2-051
EN 50581

Normes EMC:

EN 61326-1

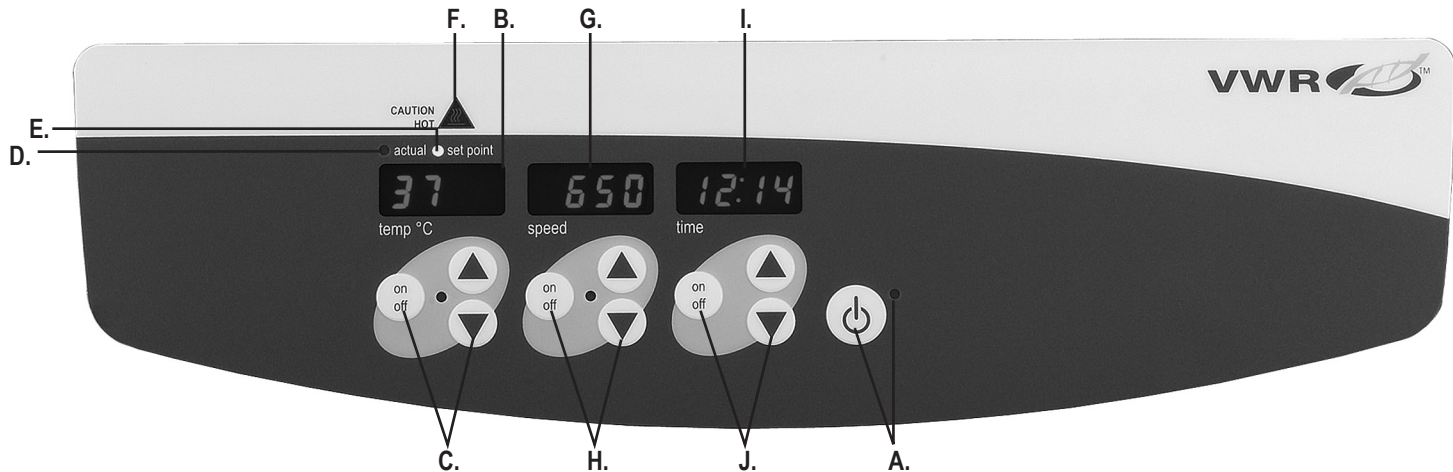

CONTROL PANEL

The front panel of the Incubating/Cooling Shaker contains all the controls and displays needed to operate the unit.

A. Standby button/standby indicator light: The standby indicator light will illuminate when the unit is plugged in. The unit will be in standby mode. Press the standby button to start the temperature, speed and time functions. The standby indicator light will shut off. Press the standby button again and the unit will once again be in standby mode.

B. Temperature display: Displays the actual/set-point temperatures in conjunction with the actual/set-point indicator lights. **C.** On/off button starts/stops the heating/cooling function. Up/down arrows for set-point control.

D. Actual indicator light: Illuminates when the temperature displayed is the actual temperature of the plate.

E. Set-point indicator light: Illuminates when the set-point temperature is displayed.

F. Caution hot indicator light: Illuminates when the temperature is above 40°C (104°F).

G. Speed display: Displays the speed of the shaker. **H.** On/off button starts/stops shaking function. Up/down arrows for set-point control.

I. Time display: Displays accumulated time (continuous mode) or how much time is remaining (timed mode). The display range is from 0 to 9,999 minutes in one (1) second increments. The display will indicate minutes and seconds until the timer reaches 99 minutes and 59 seconds (99:59), then the display will automatically display minutes up to 9,999. **J.** On/off button starts/stops the time function. Up/down arrows for set-point control.

SPECIFICATIONS

Overall dimensions: (L x W x H)	17.9 x 11 x 10.5" (45.5 x 27.9 x 26.7cm)
Electrical (50/60 Hz):	120 volts, 2 amps, 200 watts 230 volts, 1 amp, 200 watts
Fuses:	5mm x 20mm, 5 amp quick acting
Temperature range:	10°C below ambient to 65°C, when operating conditions are 15° to 40°C
Temperature uniformity:	±0.5°C at 37°C
Speed range using microplates:	100 to 1200rpm
Speed range using modular blocks:	100 to 600rpm
Speed accuracy:	±2% of set speed up to 999rpm ±5% 1000 to 1200rpm
Orbit:	3mm
Capacity:	2 microplates or 2 blocks
Timer:	digital, 1 second to 9999 minutes (increased in 1 second increments to 99:59, then in 1 minute increments)
Controls:	see page 4
Ship weight:	34lbs (15.4kg)

OPERATING INSTRUCTIONS

The Incubating/Cooling Shaker has been designed to heat/cool and shake microplates and modular blocks that have been designed to hold various sample containers such as plates, tubes and vials.

The temperature, speed and time functions work independently of one another. The temperature and speed can be re-set without re-setting the timer and the timer can be stopped and started without interrupting the heating/cooling and shaking functions.

1. Getting ready:

- Plug the cord into a properly grounded, 3-pronged outlet. The standby indicator light will illuminate, and a single audible beep will sound, verifying power to the shaker.
- Press the standby button to move the unit from standby mode. The temperature, speed and time displays will illuminate. Each display indicates the previously used settings.



2. Setting temperature:

- Press the up/down arrows below the temperature display until you reach the desired temperature. When you release the button, the display will blink off and then on indicating the new set temperature has been accepted. The lights above to the temperature display will alternate between the actual and set temperature showing both values, until five (5) audible beeps sound indicating set temperature has been reached.
- Press the on/off button to start the heating/cooling function. The indicator light below the temperature display will illuminate to indicate the heating/cooling function is in use.
- Set-point temperature adjustments can be made without interrupting heating or cooling by using the up/down arrows below the temperature display. After the change has been made and you release the button, the display will blink off and then on indicating the new set temperature has been accepted.

OPERATING INSTRUCTIONS (CONT'D)

- d. To stop heating or cooling, press the on/off button below the temperature display. The temperature indicator light will turn off.

Caution hot indicator:

The caution hot indicator light warns that the temperature is above 40°C (104°F). The light will illuminate and remain on when the temperature reaches approximately 40°C (104°F). When the heat is turned off, the caution hot indicator light will stay on until the temperature falls below 40°C (104°F).



NOTE: Microplates will heat and cool faster than the modular blocks. Displayed temperature may not be the actual temperature of the modular blocks. This may be adjusted by performing a single point calibration (see page 7) with the modular blocks in place.

3. Setting speed:

- a. Press the up/down arrows below the speed display until you reach the desired speed. When you release the button, the display will blink off and then on indicating the new set speed has been accepted.
- b. Press the on/off button to start the shaking function. The indicator light below the speed display will illuminate to indicate the shaking function is in use and will flash until the set speed is reached. The microprocessor controlled ramping feature slowly increases speed until the set-point is reached. This helps to avoid splashing, and provides excellent low end control.
- c. Speed adjustments can be made without interrupting shaking by using the up/down arrows below the speed display. After the change has been made and you release the button, the display will blink off and then on indicating the new set speed has been accepted.

NOTE: While the unit is capable of reaching 1200rpm, it is recommended that when using the modular blocks that you do not go beyond 600rpm.

4. **Setting time to zero (0:00) and continuous mode:** Accumulated time.
 - a. Press and hold the on/off button below of the time display. After three (3) seconds, the display will indicate the previous set time.
 - b. Simultaneously press both the up and the down arrows, the display will indicate zero (0:00). The unit time is now set to zero (0:00) minutes. Alternately, you can use the up/down arrows to get to zero (0:00).
 - c. Press the on/off button below the time display. The display will indicate accumulated time. The up/down arrows will become inactive. To stop timer, press the on/off button again. **IMPORTANT:** This will **NOT** interrupt the shaking function. Press the on/off button below the speed display to interrupt the shaking function.
 - d. To reset, press and hold the on/off button below the time display. After three (3) seconds the display will indicate the previous set time, which was zero (0:00).
5. **Setting timed mode:** Programmed time.
 - a. Press the up/down arrows below the time display until you reach the desired time.
 - b. Start this function by pressing the on/off button below the time display. The unit will run for the selected time, the up/down arrows will become inactive while the timer is running. The unit will stop shaking when time display reaches zero (0:00). Four (4) audible beeps will indicate the time down function is complete. The time display will default back to the set time. To repeat this function for the same set time, simply depress the on/off button again.
 - c. To interrupt an automatic timing cycle before it is completed, press the on/off button below the time display. The display will flash off and on to indicate the time function is on "hold". **IMPORTANT:** This will **NOT** interrupt the shaking function. Press the on/off button below the speed display to

OPERATING INSTRUCTIONS (CONT'D)

interrupt the shaking function. Restart the timer by pressing the on/off button below the time display. Unit will continue counting down to zero (0:00). When the display reaches zero (0:00), you will hear the four (4) audible beeps that indicate the count down function is complete and the shaking function will stop.

6. Turning unit off:

- a. To turn the unit off, press the standby button. The temperature, speed and time displays will be blank, the standby indicator light will illuminate. The Incubating/Cooling Shaker should be kept in standby mode when not in use.

OPERATING TIPS

Shaker will automatically restart after a power interruption. Built-in memory maintains the last used temperature, speed and time settings during a power interruption.

The shaker will shut down if the tray is prevented from rotating, or the unit is overloaded beyond the recommended weight capacity.

If using modular blocks, it is recommended to secure blocks on the unit before loading the samples.

BEEPER PREFERENCE (muting audible alarm)

To silence beeper operation (except for error codes), with the unit in standby mode, press and hold the time on/off button and press the standby button. Release the standby button first, and then release the on/off button. To restore normal beeper operation, remove AC power to unit for 10 seconds and then restore.

SINGLE POINT CALIBRATION PROCEDURE

This procedure is used to fine tune and calibrate the Incubating/Cooling Shaker at a specific temperature setting. This process may be repeated for up to three (3) separate set-points. If a fourth calibration set-point is entered, the first set-point entered will be overwritten.

1. Turn unit on.
2. Set desired temperature.
3. Stabilize one (1) hour or more, measuring the temperature with a precision instrument or thermometer.
4. Press and hold standby button, then press the temperature up button once. The unit will beep two (2) times, confirming calibration mode. The display will now be flashing.
5. Press the temperature up/down arrows until the display matches the temperature probe/thermometer.
6. Press the standby button to exit calibration mode and return to normal heating/cooling.

This process may be repeated at the same set-point, multiple times for fine tuning if desired.

The unit will now use the biased offset for that specific temperature setting and increase or decrease temperature accordingly to bring the temperature to set temperature. The decimal point of the display will flash to indicate a biased offset is being used. All other temperature settings will use the standard internal calibration. This offset will be stored in memory and retained until reset.

TO RESTORE UNIT TO FACTORY SETTING

Press and hold standby button while pressing the temperature down button once. The reset will be confirmed with two (2) audible beeps. Press the standby button to exit calibration mode and return to normal heating/cooling.

TROUBLESHOOTING

During operation, any rattling or ticking sounds may indicate a loose screw on the tray, a tray attachment or an accessory. All accessories should be sufficiently tightened in place before starting the unit.

<u>Error Code</u>	<u>Software Test</u>	<u>Cause</u>
E04	unit overloaded	maximum load exceeded loose foot (suction cup)*

The E04 error can be addressed by the user. Press the standby button to clear this error. Be sure the load is within the maximum load specification before restarting the unit. If the E04 code persists, switch the unit off and contact your VWR representative for repairs.

<u>Error Code</u>	<u>Software Test</u>	<u>Cause</u>
E03	drive system failure	loose foot (suction cup)* mechanical obstruction ceased bearing drive belt broken

If the E03 error persists, along with grinding, knocking or rubbing noises, the reason may be one of the other three (3) causes and should **NOT** be addressed by the end user. Switch the unit off and contact your VWR representative for repairs.

* In the event a foot (suction cup) has come loose from the bench top, the unit will register an errant E03 or E04 message due to the instability of the unit. Press the standby button to clear this error, then firmly press down on the four (4) corners of the unit, creating a strong suction to the work surface (**DO NOT** place on bench mat). Press the standby button to resume operations.

<u>Error Code</u>	<u>Cause</u>
E02	RTD shorted or temperature below 0°C

E02 error should **NOT** be addressed by the end user. Switch the unit off and contact your VWR representative for repairs.

<u>Error Code</u>	<u>Cause</u>
E01	RTD open or temperature over 100°C

E01 error should **NOT** be addressed by the end user. Switch the unit off and contact your VWR representative for repairs.

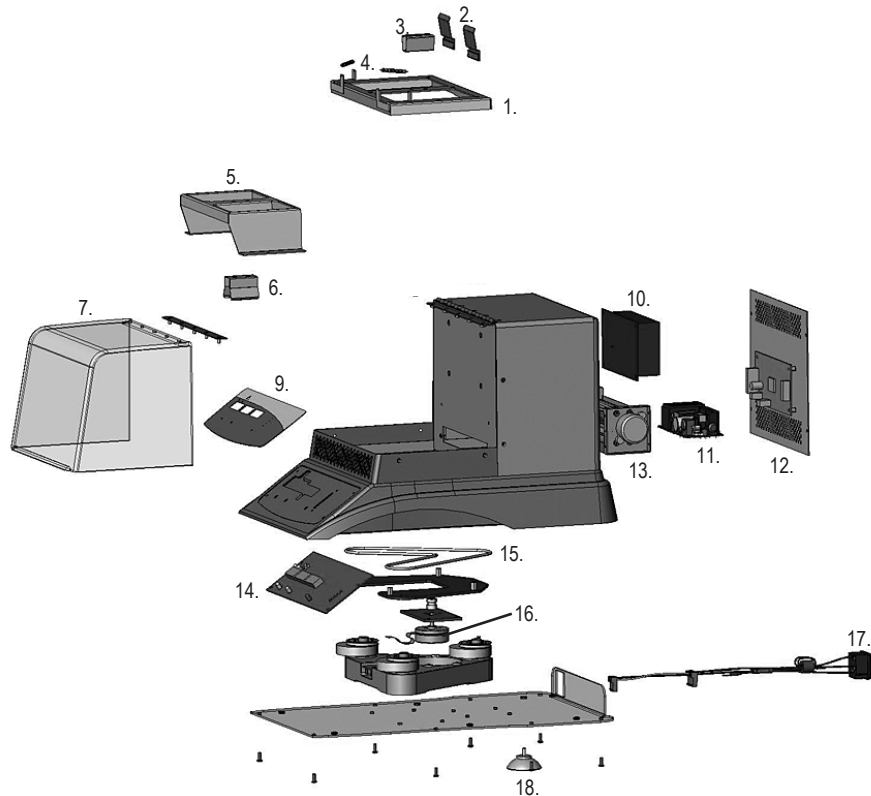

DESCRIPTION

PART NUMBER

1. Top shield	80854600
2. Rear spring clip	80854605
3. Spring clip microtiter	80857425
4. Extension spring	80853227
5. Modular block holder	80854601
6. Center spring clip	80854609
7. Lid	80854593
9. Membrane switch	80856553
10. AC/DC switching power supply	80856578
11. Power supply	80856504
12. PCB incubating/cooling	80856559
13. Cross flow fan	80854597
14. PCB display incubating/cooling	80856558
15. Drive belt	80857411
16. Motor 50W	80856595
17. Power inlet wiring assembly	80856582
18. Feet (suction cup)	80857281

Detachable 92" (234cm) power cord:	120V	80856139
	EURO	12120761
	UK	12120312
	SWISS	80856142

MODULAR BLOCKS

Modular blocks are constructed from a solid anodized aluminum block. The close contact of tubes-to-block walls allows for maximum temperature transfer.

Block dimensions (L x W x H): 3.75 x 3 x 2" (9.5 x 7.6 x 5.1cm)

Microcentrifuge Tube Blocks

Sample Type	No. of Wells	Well Dia.	Well Depth	VWR Cat. No.
.5mL tube	30	7.9mm	27.6mm	13259-000
1.5mL tube	20	11.1mm	39.1mm	13259-286
2mL tube	20	11.5mm	38.1mm	12985-048

Conical-Bottom Centrifuge Tube Blocks

Sample Type	No. of Wells	Well Dia.	Well Depth	VWR Cat. No.
15mL tube	12	17.1mm	44.5mm	13259-250
50mL tube	5	29.0mm	47.6mm	13259-254

Standard Test Tube Blocks

Sample Type	No. of Wells	Well Dia.	Well Depth	VWR Cat. No.
6mm tube	30	8.3mm	48.4mm	13259-105
10mm tube	24	10.7mm	48.4mm	13259-107
12/13mm tube	20	13.9mm	48.4mm	13259-130

Centrifuge Tube Combination Block

Sample Type	No. of Wells	Well Dia.	Well Depth	VWR Cat. No.
1.5mL	4	11.1mm	39.1mm	12985-040
15mL	3	17.1mm	44.5mm	
50mL	2	29.0mm	47.6mm	

Vial Blocks

Sample Type	No. of Wells	Well Dia.	Well Depth	VWR Cat. No.
12mm vial	20	12.7mm	30mm	12621-124
15mm vial	20	15.8mm	35mm	12621-126
16mm vial	15	16.4mm	45mm	12985-066
17mm vial	12	17.8mm	45mm	12621-128
19mm vial	12	19.7mm	45mm	12621-130
21mm vial	9	21.7mm	45mm	12621-132
23mm vial	8	23.8mm	45mm	12621-134
25mm vial	8	25.8mm	45mm	12621-136
28mm vial	6	28.8mm	45mm	12621-138



MANUFACTURED BY:

TROEMNER, LLC

201 Wolf Drive • PO Box 87 • Thorofare, NJ 08086-0087
Phone: 856-686-1600 • Fax: 856-686-1601 • E-mail: troemner@troemner.com
www.troemner.com

80858903 (REV C- 3/22)