

User Manual

VWR P2-SERIES BALANCES



AUGUST 2017

TABLE OF CONTENTS

1. INTENDED USE	5
2. PRECAUTIONS	5
2.1. Maintenance	5
2.2. Accumulator / batterypack.....	5
2.3. Operation in a strong electrostaticfield	6
2.4. Maintenance activities	6
3. WARRANTY CONDITIONS	7
4. MAIN DIMENSIONS	8
5. UNPACKING AND ASSEMBLY	9
6. UNDER-PAN WEIGHING	9
7. GETTING STARTED	11
8. BALANCE LEVELING	11
9. KEYPAD	11
10. KEYS' FUNCTIONS	12
11. INSCRIPTIONS ON THE DISPLAY	12
12. USER MENU	13
12.1. Submenus.....	13
12.2. Browsing user menu	14
12.2.1. Keypad.....	14
12.2.2. Return to the weighing mode	15
13. WEIGHING	15
13.1. Taring.....	16
13.2. Inscribing tare value	17
13.3. Zeroing.....	17
13.4. Selection of basic weight unit.....	18
13.5. Temporarily selected unit	19
14. MAIN PARAMETERS	20
14.1. Setting a filtering level.....	20
14.2. Median filter	21
14.3. Autozero function	21
14.4. Tare function	22
15. RS 232 PARAMETERS	24
15.1. Printout type	24
15.2. Minimal mass threshold	25
15.3 Baud Rate.....	26
15.4 Serial transmission parameters	27
16. OTHER PARAMETERS	28
16.1. Backlight function	28
16.1.1 Backlight for supplying from mains	28
16.1.2. Backlight for supplying from batteries	29
16.2. "Beep" signal – after pressing a key.....	29
16.3. Automatic switch-off	30
16.4. Battery voltage levelcheck.....	31
16.4.1. Checking the batteries	31
16.4.2. Battery discharge pictogram.....	32
16.4.3. Accumulator charging option	32
17. OPERATION MODES	33
17.1. Setting accessibility of operation modes	33
17.2. Selecting quantity of operation modes	34
17.3. Counting pieces of the same mass	34
17.4. +/- control referring to the inscribed standard mass Procedure:.....	37
17.5. Control of % deviation referring to the inscribed standard mass.....	38
17.5.1. Standard mass determined by its weighing	39

17.5.2.	Mass of standard inscribed to scale memory.....	40
17.6.	Automatic tare	41
17.7.	Measurement of maximal force on the pan –latch	42
17.8.	Totalizing	43
17.8.1.	Enabling the work mode.....	43
17.8.2.	Totalizing procedure	43
17.8.3.	Memory of the last value of sum of weighed goods	44
17.8.4.	Return to weighing	45
17.9.	Weighing animals.....	46
17.10.	Tare memory.....	48
17.10.1.	Entering the tare value to the scale memory.....	48
17.10.2.	Selecting a tare value from the memory	49
18.	SCALE CALIBRATION.....	50
19.	COOPERATION WITH PRINTER	52
20.	COOPERATION WITH COMPUTER.....	53
21.	COMMUNICATION PROTOCOL	54
21.1.	General information.....	54
21.2.	A set of commands for RS interfaces	55
21.3.	Respond message format	55
21.4.	Command's description.....	56
21.4.1.	Zeroing	56
21.4.2.	Tarring	56
21.4.4.	Set tare value	57
21.4.5.	Send the stable result in basicunit.....	57
21.4.6.	Send the result immediately in basicunit	57
21.4.7.	Send the stable result in currentunit.....	58
21.4.8.	Send the result immediately in currentunit	58
21.4.9.	Switch on continuous transmission in basicunit	59
21.4.10.	Switch off continuous transmission in basic unit	59
21.4.11.	Switch on continuous transmission in current unit	60
21.4.12.	Switch off continuous transmission in currentunit	60
21.4.13.	Lock the scale keyboard.....	60
21.4.14.	Unlock the scale keyboard	60
21.4.15.	Give serial number	61
21.4.16.	Send all implemented commands	61
21.5.	Manual printouts / automatic printouts	61
21.6.	Continuous transmission.....	62
22.	ERROR COMMANDS.....	63
23.	TROUBLE SHOOTING.....	63

1. INTENDED USE

Scales are designed for fast and precise measurements of weighed loads masses and direct commercial settlements. Taring in full weighing range enables to determine net mass of weighed loads.

Functions:

- Backlight of display
- Level of filtration
- Autozero function
- Setting baud rate of transmission
- Continuous data transmission for RS 232
- Automatic operation for RS232
- Designed printouts
- Designation minimum mass for function operating
- Counting pieces
- +/- mass control
- Percentage deviation from standard mass
- Latch of maximum scale indication
- Automatic tare
- Memory of tare
- Inscribing tare value
- Memory of 9 tare values
- Automatic scale switch-off
- User calibration
- Totalizing
- Weighing animals

2. PRECAUTIONS

2.1. Maintenance

- A. Please, read carefully this user manual before and use the device according to its intended use.
- B. Devices that are to be withdrawn from use age should be sent back to the producer or in case of own utilization do it accordance to the law.

2.2. Accumulator / battery pack

The device connected to mains power monitors the battery state and charges it if possible. After sudden lack of power supply from the mains the device automatically switches to accumulator without breaking operation.

- **VWR** scales are devices designed to be supplied from **SLA** accumulators (*Sealed lead acid type*) **6V** and capacity **3 to 4Ah** charged while connected to mains without stopping operation.



In case of an elongated storage period in low temperatures, it is not allowed the full discharge of the accompanied batteries.



The equipment including accumulators does not belong

to your regular household waste. The European legislation requires that electric and electronic equipment be collected and disposed separately from other communal waste with the aim of being recycled.

Caution:

Some symbols on accumulators identify harmful elements/compounds: Pb = lead, Cd = cadmium, Hg = mercury.

2.3. Operation in a strong electrostatic field

If the device is about to be operated in a strong electrostatic field (e.g. printing houses etc.) it should be grounded.

Connect it to the clamp terminal signed \perp .

2.4. Maintenance activities

It is necessary to uninstall the weighing pan and other detachable components prior to cleaning the balance, this guarantees safety.

Cleaning ABS components

To clean dry surfaces and avoid smudging, use clean non-coloring cloths made of cellulose or cotton. You can use a solution of water and detergent (soap, dishwashing detergent, glass cleaner). Gently rub the cleaned surface and let it dry. Repeat cleaning process if needed.

In the case of contamination which is hard to remove, e.g. adhesive, rubber, resin, polyurethane foam residues etc., you can use a special cleaning agents based on a mixture of aliphatic hydrocarbons that do not dissolve plastics. Before using the cleanser for all surfaces, we recommend carrying out tests. Do not use products containing abrasive substances.

Cleaning stainless steel components

Avoid using cleansers containing any corrosive chemicals, e.g. bleach (containing chlorine). Do not use abrasive substances. Always remove the dirt using microfiber cloth to avoid damage of protective coating.

In case of a daily maintenance:

1. Remove the dirt using cloth dipped in warm water.
2. For best results, add a little dishwashing detergent.

Cleaning powder-coated components

For the preliminary cleaning stage, you need a wet sponge featuring large holes, this will help you to remove loose, heavy dirt.

Do not use cleansers containing abrasive substances.

Next using cloth and cleanser-water solution (soap, dishwashing liquid) gently rub the cleaned surface.

Avoid using cleanser without water since it may result in damage of the cleaned surface, please note that large amount of water mixed with cleanser is a must.

Cleaning aluminium components

While cleaning aluminium components, use products acidic in nature, e.g. spirit vinegar, lemon. Do not use abrasive substances. Avoid using a hard brush, this may cause scratches. It is recommended to use a microfiber cloth.

While polishing the surface use circular movements. Use clean, dry cloth.

3. WARRANTY CONDITIONS

- A. VWR is obliged to repair or change those elements that appear to be faulty because of production and construction reason,
- B. Defining defects of unclear origin and outlining methods of elimination, can be settled only in participation of a user and the manufacturer representatives,
- C. VWR does not take any responsibility connected with destructions or losses derives from non-authorized or inappropriate (not adequate to manuals) production or service procedures,
- D. Warranty does not cover:
 - Mechanical failures caused by inappropriate maintenance of the device or failures of thermal or chemical origin or caused by atmospheric discharge, over voltage in mains, or other random event,
 - Inappropriate cleaning.
- E. Loss of warranty appears after:
 - Access by an unauthorized service
 - Intrusion into mechanical or electronic construction of, unauthorized people
 - Removing or destroying protection stickers.
- F. Warranty conditions outline the warranty period for rechargeable batteries attached to the device for 12 months.
- G. The detailed warranty conditions one can find in warranty certificate.

4. MAIN DIMENSIONS

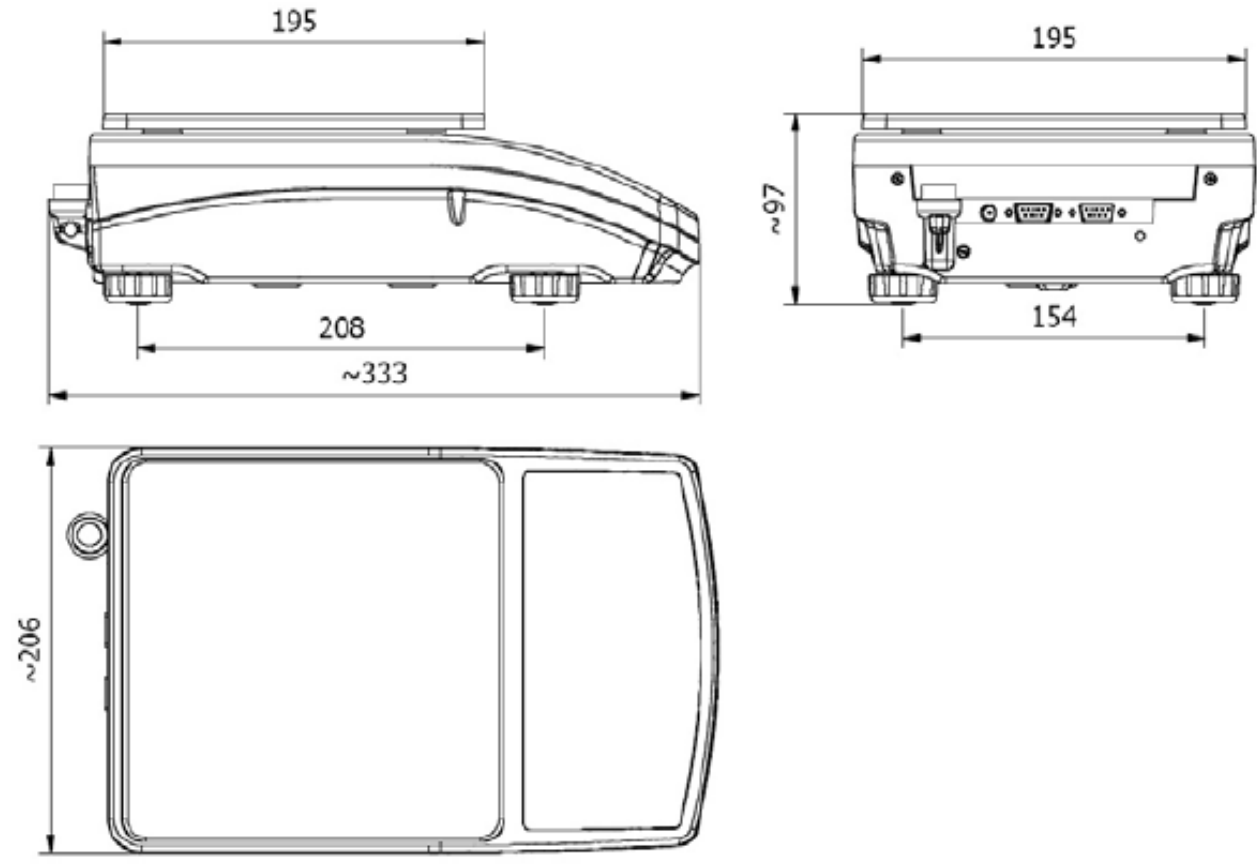

5. UNPACKING AND ASSEMBLY

- Unpack and put the scale on a flat even stable surface far away from sources of heat,
- Install the weight pan according to the drawings below:

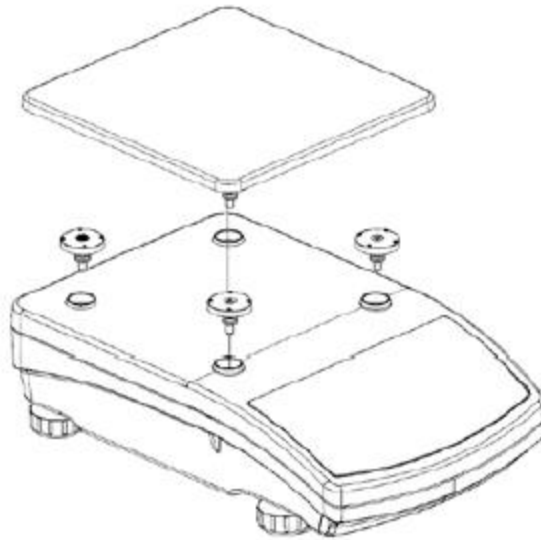

6. UNDER-PAN WEIGHING

The scale offers under-pan weighing option wherein the load is weighed when hanged under the device. This is especially useful when there is a need to weigh a load of non-standard dimension, shape, or load that generates an electromagnetic field.

Preparing the scale for under-pan weighing:

1. Unpack the scale, assemble it, then turn the scale one side down.

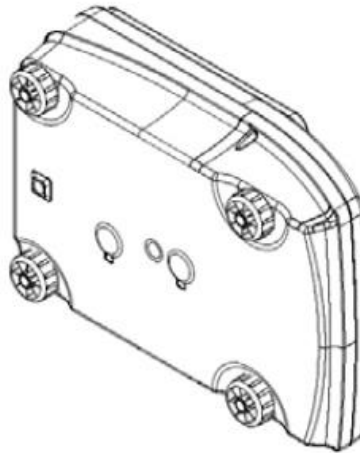

2. Remove the hole plug.

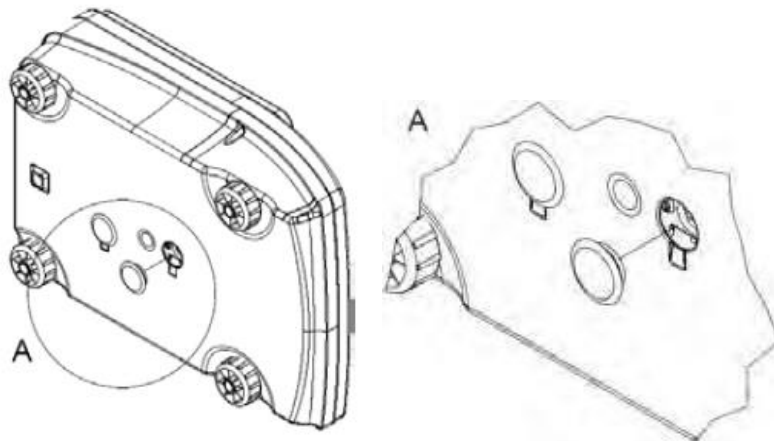

3. Fix the hook.

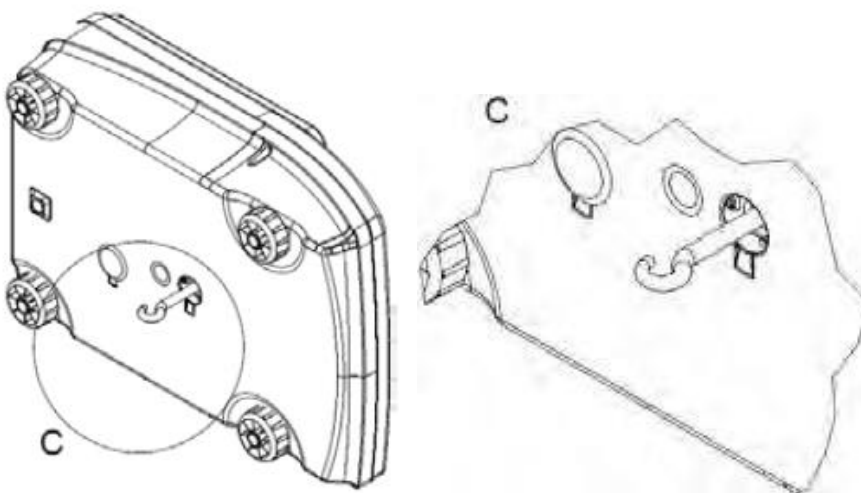
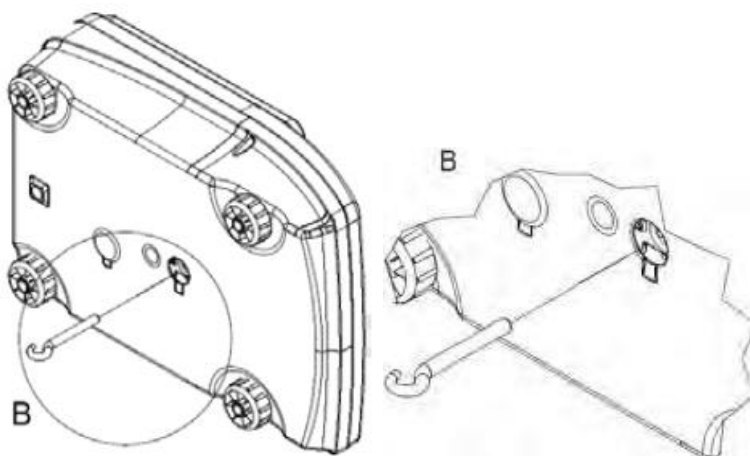



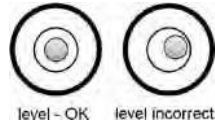

4. Turn the scale bottom side down.

7. GETTING STARTED

- After unpacking and mounting the scale, level the scale. Adjust the leveling feet until the leveling bubble reaches the correct location.



- Turn the device on using the  key – keep pressing the key for about 0.5 sec
- Wait for the test completion
- Then you will see **zero indication** and pictograms:  - zero indication
 - stable result
kg - weight unit
- If the indication is not zero press  key.

8. BALANCE LEVELING

- Operation temperature range for this device is outlined as +15°C ÷ +30°C;
- After powering up this device requires 30 minute warming up
- During the warm-up time the indication can change
- User calibration should be performed after the warm-up time.
- Temperature and humidity changes during operation can increase measurement errors, which can be minimized by performing the user calibration process.

9. KEYPAD

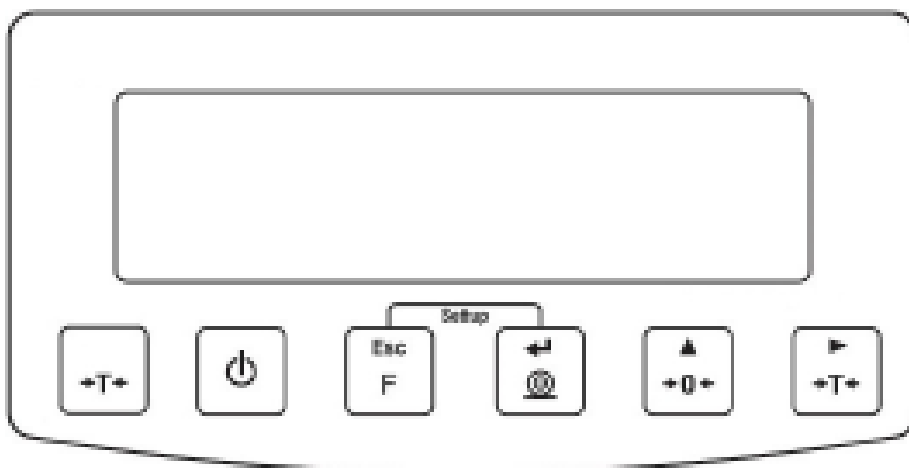

10. KEYS' FUNCTIONS



Switching on/off

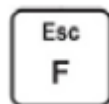

Function key (operation mode selection)



Sending a weighing result to RS232

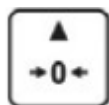



Zeroing



Tarring

Notice:

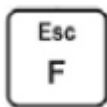

After pressing  +  keys' functions changes. The way of operation in this mode is described in details further in this manual.

11. INSCRIPTIONS ON THE DISPLAY

No	Text string	Description
1	FIL	Filter level
2	bAud	Transmission baud rate
3	PCS	Piece counting
4	HiLo	+/- control according to a standard mass
5	rEPL	Automatic printout
6	StAb	The condition of printing data
7	Auto	Autozero correction
8	t1	Power save – time to switch off while no operation
9	toP	Latch of the max measurement
10	Add	Totalizing
11	AnLS	Weighing animals
12	tArE	Memory of 9 tare values

13		Indication in autozero zone (indication = exact zero)
14		Stable result (ready to read)
15	PCS	Operation mode - counting pieces
16	kg (g)	Operation mode - weighing
17		Rechargeable battery pack or battery discharged (BAT-LO)
18	Net	Tare function has been used
19	Min	+/- control with reference to the standard mass: setting the lower threshold or mass below the first threshold
20	OK	+/- control with reference to the standard mass: load mass between the thresholds
21	Max	+/- control with reference to the standard mass: setting the upper threshold or mass over the second threshold

12. USER MENU

12.1. Submenus

User's menu is divided into **6** basic submenus. Each group has its own characteristic name preceded by the letter **P** and a number.

P1	rEAd		
	P1.1	Fil	3
	P1.2	Auto	YES
	P1.3	tArA	no
	P1.4	Fnnd	YES
P2	Prnt		
	P2.1	Pr_n	StAb
	P2.2	S_Lo	
	P2.3	bAud	9600
	P2.4	S_rS	8d1SnP
P3	Unit		
	P3.1	StUn	kg
P4	Func		
	P4.1	FFun	ALL
	P4.2	Funi	no
	P4.3	PcS	no
	P4.4	HiLo	no
	P4.5	PrcA	no
	P4.6	Prcb	no
	P4.7	AtAr	no
	P4.8	toP	no
	P4.9	Add	no
	P4.A	AnLS	no

P5	P4.b	tArE		no
	othr			
	P5.1	bL		Auto
	P5.2	bLbt		70
	P5.3	bEEP		YES
	P5.4	t1		Auto
P6	P5.5	CHr6		YES
	CAL			
	P6.1	St_u		* FUNCTION *
	P6.2	uCAL		* FUNCTION *
	P6.3	CA-C		0
	P6.4	CA-r		YES

12.2. Browsing user menu

Use scale's keys to move inside the menu.

12.2.1. Keypad



Entering main menu

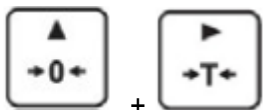

Inscribing tare value Increasing a digit value by "1" moving down in the menu



Battery / accumulator state monitoring

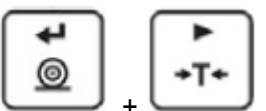

Toggling between gross / net values



Selecting the parameter or changing the value of a selected parameter



Entering the selected submenu or activating a parameter for changes



Confirmation (enter)

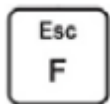

Leaving without changes or reaching a higher level of the menu

12.2.2. Return to the weighing mode



The changes that have been introduced should be saved in order to keep them in the memory for good.



While leaving parameters press  key until the text **<SAuE?>** appears on the display. Then press:



– to save changes or



– to leave without changes.

13. WEIGHING

Place a load you want to weigh on the weighing pan. When the  pictogram appears, it means that the result is stable and ready to read. In order to assure long-term operation and appropriate measurements of weighted loads, the following precautions should be taken into consideration:

- Loads should be placed on the pan delicately and carefully in order to avoid mechanical shocks:

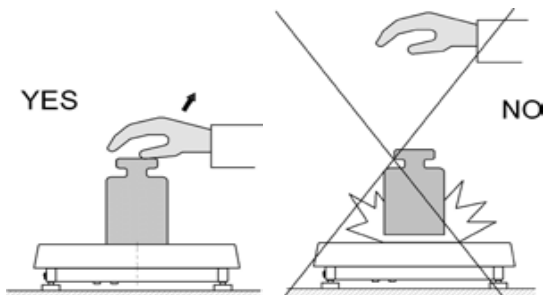

- Loads should be placed centrally on the pan (errors caused

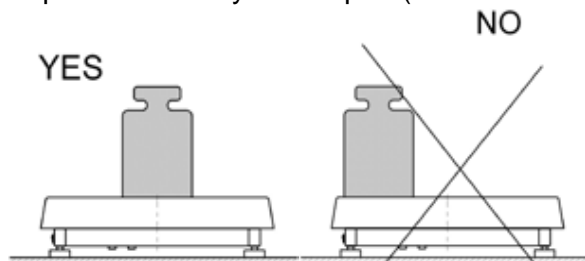

by eccentric weighing are outlined by standard PN-EN 45501 ch. 3.5 and 3.6.2):

- Do not load the pan with concentrated force:

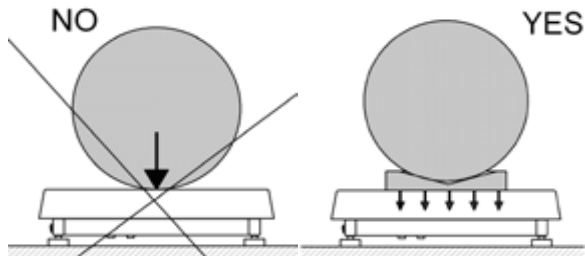

- Avoid side loads, particularly side shocks should be avoided

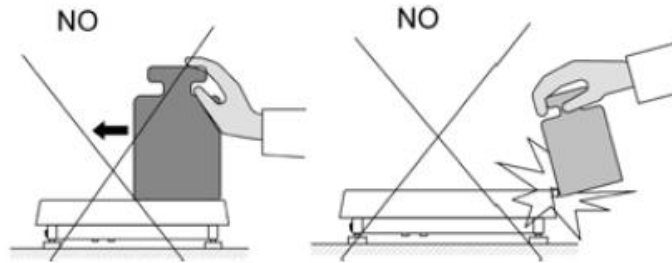

13.1. Taring

In order to determine the net mass put the packaging on the pan. After stabilizing press -



(**Net** pictogram will be displayed in the left upper corner and zero will be indicated).

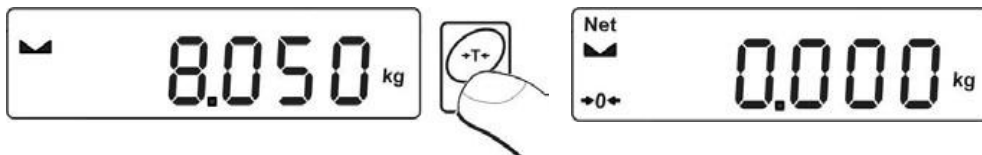

After placing a load on the weight pan net mass will be shown.

Taring is possible within the whole range of the scale. After unloading the pan the display shows the tarred value with minus sign.





Notice:



*Taring cannot be performed when a negative or zero value is being displayed. In such case **Err3** appears on the display and short audible signal will be emitted.*

13.2. Inscribing tare value

You can also inscribe a tare value. While in weighing's mode press:

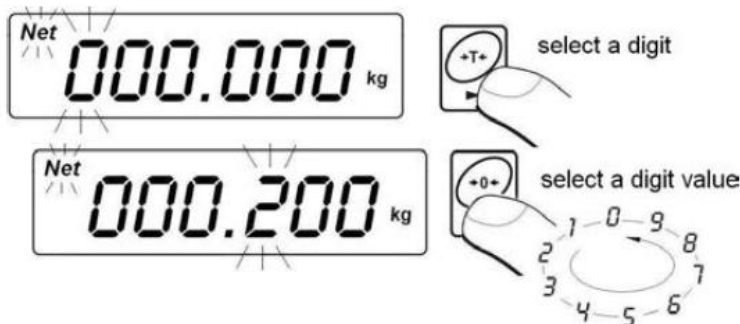
- Press simultaneously  and ,
- You will see :





- Using  and  set **the tare value**,
- Press ,
- Program returns to weighing's mode. The inscribed tare value can be seen on the display with "-" sign,
- Tare can be inscribed anytime in weighing's mode.

Notice:

1. You cannot inscribe a new tare value when the tare value in memory is greater than zero. In the case of trying this the **<Err3>** message will be displayed and short audible signal will be emitted.
2. Users can also enter up to 9 tare values to the scale memory.

13.3. Zeroing

To **ZERO** the scale press: .

The scale will display zero and following pictograms:  and . Zeroing is only possible within the scope of $\pm 2\%$ of full scale. While zeroing outside the scope of $\pm 2\%$ you will see **<Err2>**. Zeroing is possible only in stable state.

Notice:

Zeroing is possible only within the $\pm 2\%$ interval of the maximal range. If zeroing is performed beyond this range the **<Err2>** message and short audible signal will be emitted.

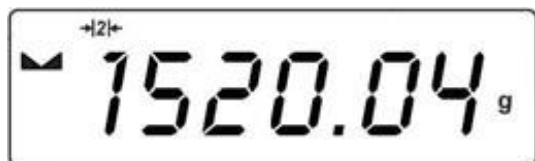



13.4. Selection of basic weight unit

This function is used to set weight unit the scale will start with.

Procedure:

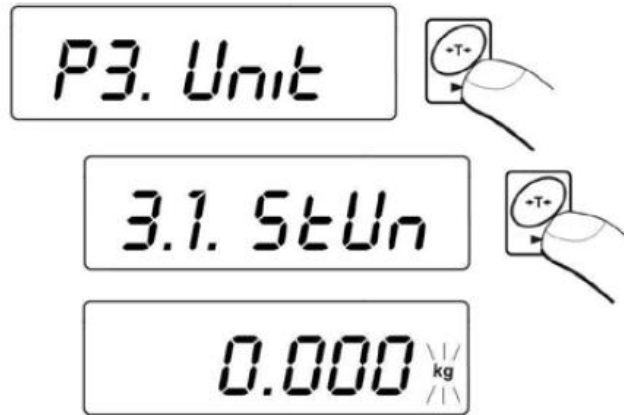
- Enter the submenu **<P3.Unit>** and then:



- press , until the expected unit appears on the display:



- After you select the unit press  the scale returns to:

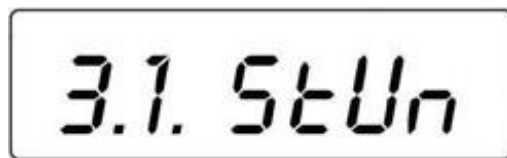

- Return to weighing according to chapter - 12.2.2.

Notice:

After turning on the scale, it always starts with the basic unit.

13.5. Temporarily selected unit

This function is used to set weight unit the scale will use temporarily until the next power off or next selection.

Procedure:

- Press  and then:

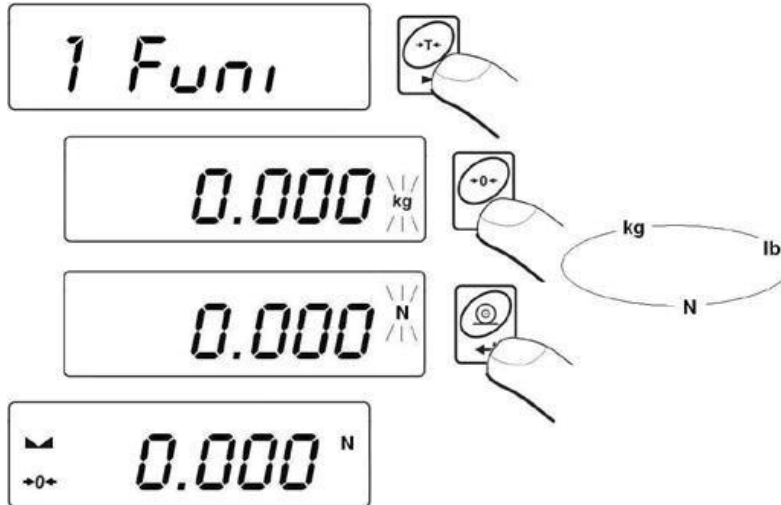

- After you select the unit you want come back to weighing procedure.

14. MAIN PARAMETERS

Users can adjust the scale to external ambient conditions (filtering level) or particular needs (autozero operation, tare memory). These parameters are placed in **<P1.rEAd>** submenu.

14.1. Setting a filtering level

Procedure:

- Enter the submenu **<P1.rEAd>** and then:

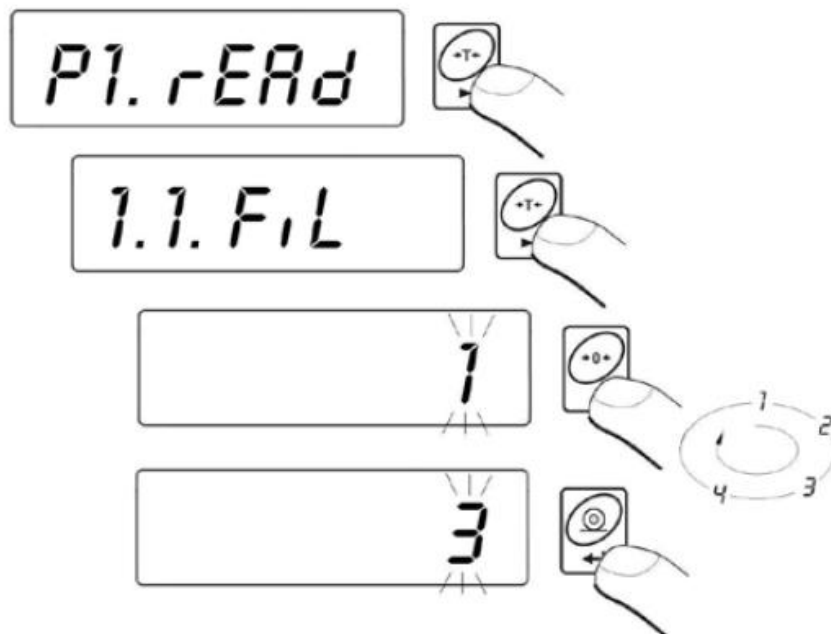

1 - 4 - level of filtering

- By pressing  select the filtering level you need

Notice:

Filtering level influences the time of stabilization. The higher the filtering level, the longer stabilization time is needed.

Return to weighing:

See - 12.2.2.

14.2. Median filter

This filter eliminates short changes (impulses) of measure signal (e.g. shocks).

Procedure:

- Enter the submenu <P1.rEAd> and then:

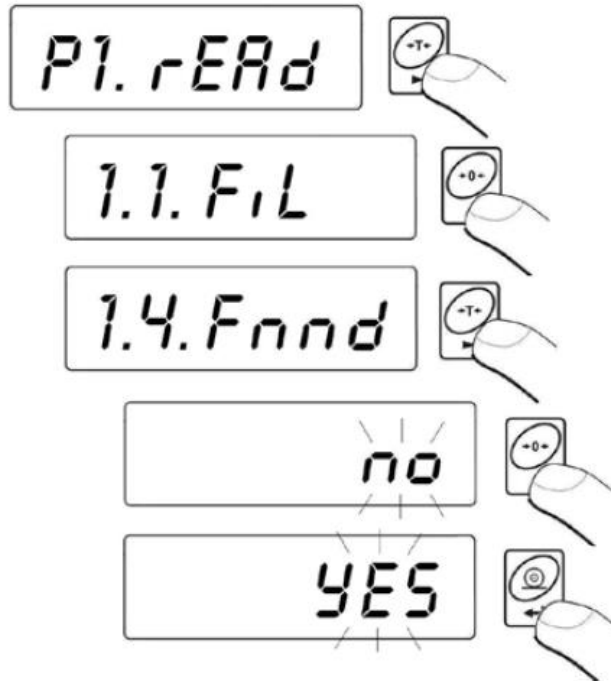

Fnnd no - filter disabled
Fnnd YES - filter enabled

Return to weighing:

See - 12.2.2.

14.3. Autozero function

The autozero function has been implemented in order to assure precise indications. This function controls and corrects "0" indication. While the function is active it compares the results continuously with constant frequency. If two sequential results differ less than the declared value of autozero range, so the scale will be automatically zeroed and the pictograms  and =0= will be displayed.

When AUTOZERO is disabled zero is not corrected automatically. However, in particular cases, this function can disrupt the measurement process e.g. slow pouring of liquid or powder on the weighing pan.

In this case, it is advisable to disable the autozero function.

Procedure:

- Enter the submenu <P1.rEAd> and then:

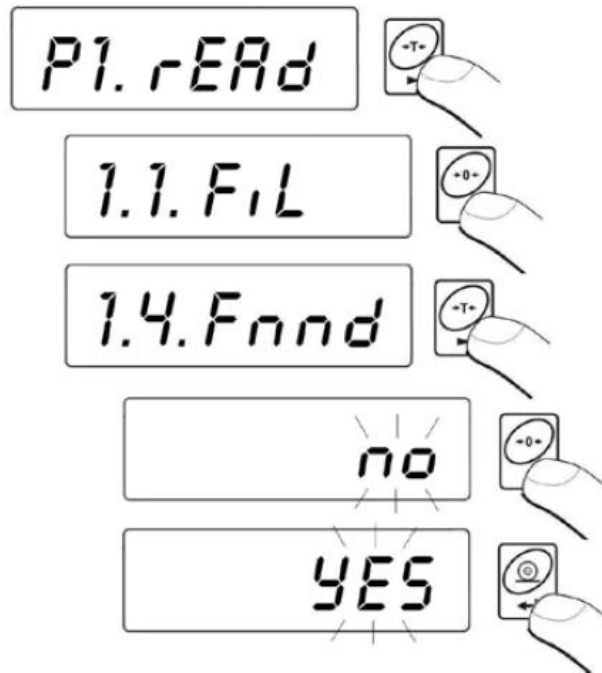

Fnnd no - filter disabled
Fnnd YES - filter enabled

Return to weighing:

See - 12.2.2.

14.4. Tare function

This parameter enables users to configure a tare function.

Procedure:

- Enter the submenu <P1.rEAd> and then:



- tArA AtAr** - **automatic tare function on** and is stored in balance memory after unplugging it from mains (Description of function operating point 16.6 automatic tare)
- tArA no** - **automatic tare function off** (user can turn on operating of automatic tare F6 AtAr – till unplugging the balance from mains)
- tArA tArF** - **tare memory function** – stores last value of tare in balance memory. It is automatically displayed after starting the balance. Value of tare is displayed with minus sign, and there is **Net** symbol indicated on the display. (user can turn on operating of automatic tare **F6 AtAr** – till unplugging the balance from mains)

Return to weighing:
See - 12.2.2.

15. RS 232 PARAMETERS

External devices connected to RS 232C have to be supplied from the same mains and common electric shock protection. It prevents from a potential difference between zero leads of the two devices. This notice does not apply to the devices that do not use zero leads.

Transmission parameters:

- Baud rate - 2400 – 38400 bit /s
- Data bits - 7,8
- Stop bits - 1,2
- Parity control - no, even,odd

There are four ways of sending data via RS232 interface:

- **Manually** – after pressing  ,
- **Automatically** – after stabilizing the indication over **-LO-** threshold
- **Continuously** – after it is activated in parameter or by a command sent via RS232
- **On external request** - see - "List of scale - computer commands".

The indication can be sent as:

- **stable** – the indication is sent after the scale stabilizes.
- **any** – the indication is sent immediately after pressing the  key, this state is assign with **<?>** in the printout.

15.1. Printout type

This parameter is to select the type of printout.

Procedure:

- Enter the submenu **<P2.Prnt>** and then:

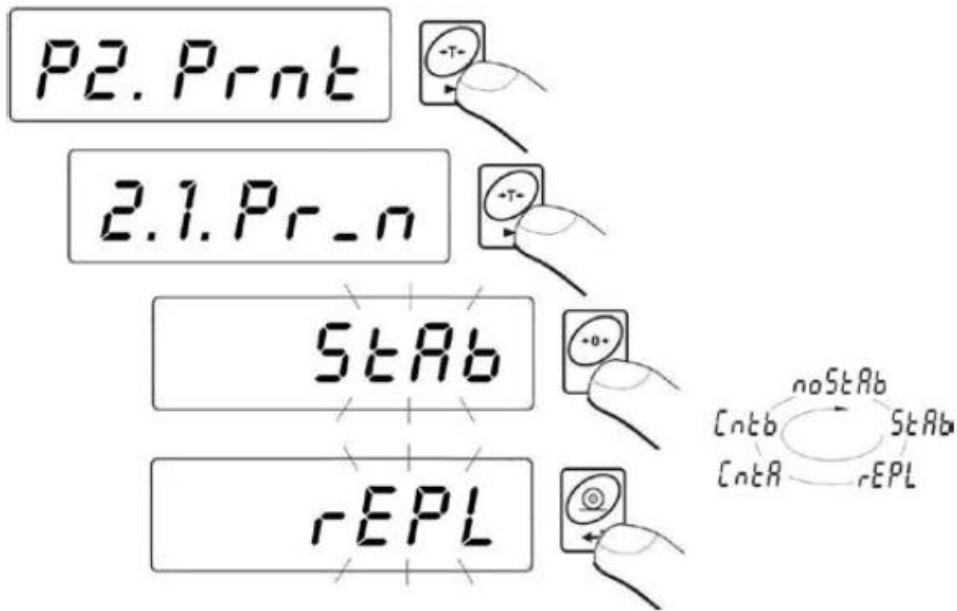

- Pr_n noStAb - immediate printout
(not accessible in verified scales)
- Pr_n StAb - sending stable results
- Pr_n rEPL - automatic operation
- Pr_n CntA - continuous transmission in basic unit
- Pr_n Cntb - continuous transmission in present unit

Return to weighing:
see 12.2.2.

15.2. Minimal mass threshold

This function is necessary while working with **automatic tare** or automatic operation or weighing animals.

Automatic taring will not be applied until the indication (gross) is lower than the value inscribed in **S_Lo** parameter.

In automatic operation measurements (net) are sent via RS232 when the indication is equal or greater than the value inscribed in **S_Lo** parameter.

Weighings animals is performed when the indication is equal or greater than the value inscribed in **S_Lo** parameter.

Procedure:

- Enter the submenu <P2.Prnt> and then:

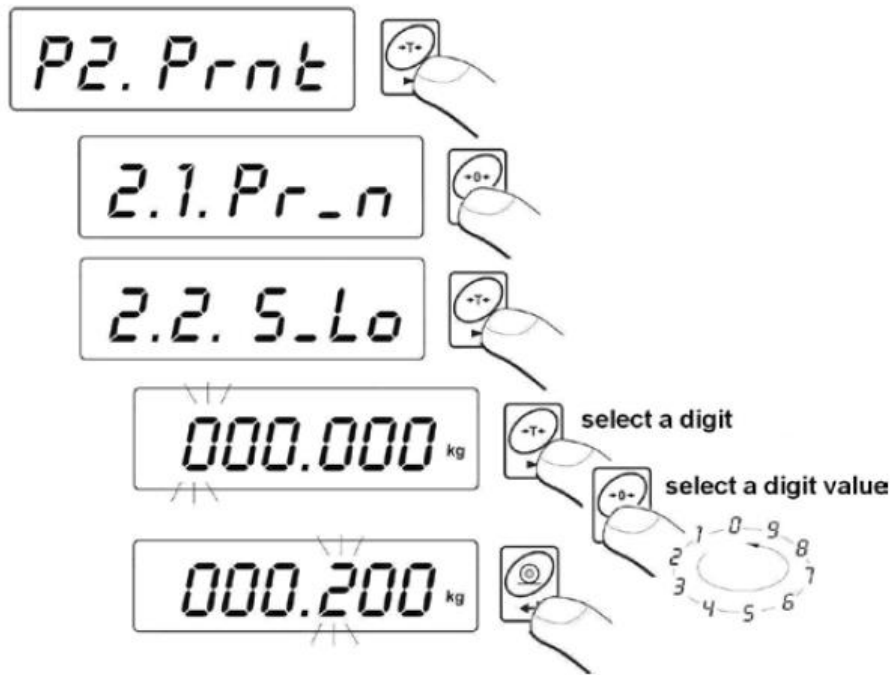

Return to weighing:
see 12.2.2.

15.3 Baud Rate

Procedure:

- Enter the submenu <P2.Prnt> and then:

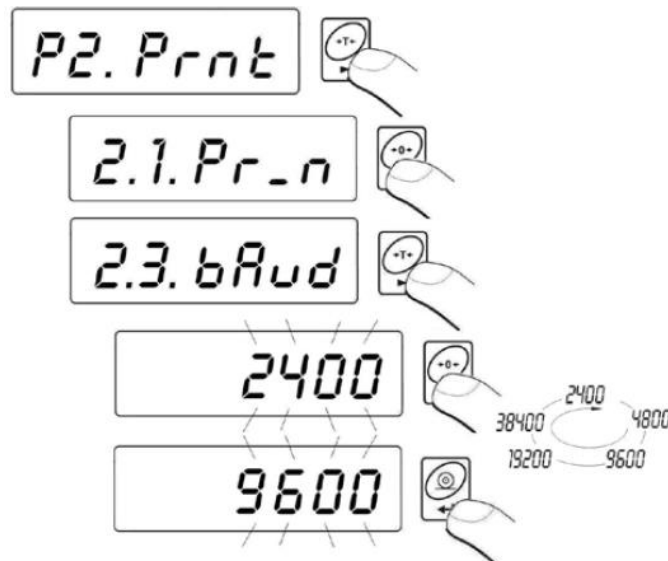

Return to weighing:
see 12.2.2.

15.4 Serial transmission parameters

Procedure:

- Enter the submenu **<P2.Prnt>** and then:

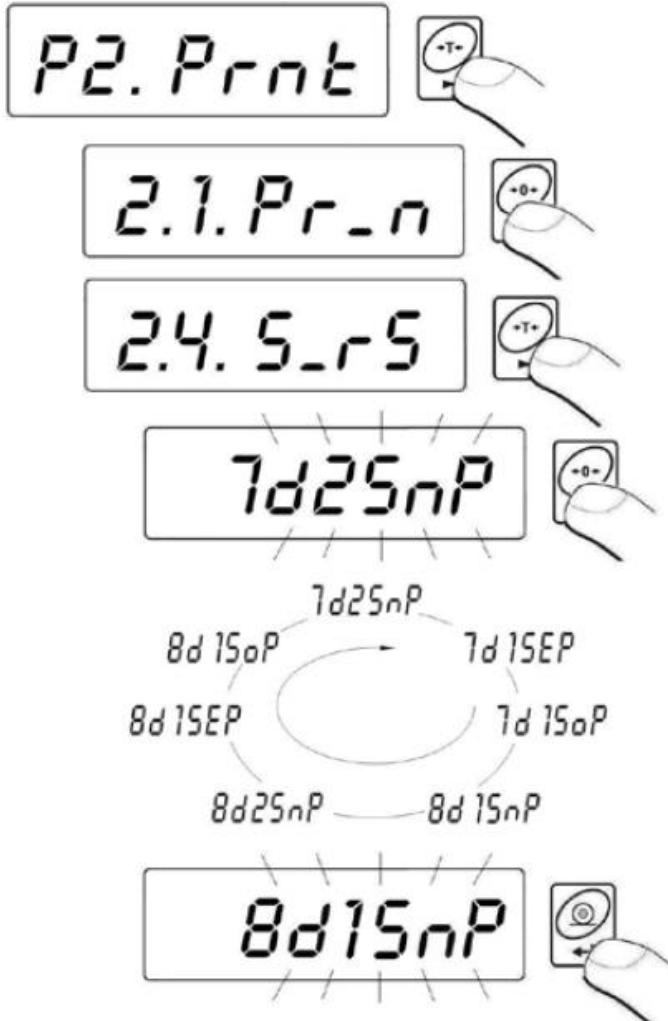

- 7d2SnP** - 7 data bits; 2 stop bits, no parity control
- 7d1SEp** - 7 data bits; 1 stop bit, EVEN parity control
- 7d1SoP** - 7 data bits; 1 stop bit, ODD parity control
- 8d1SnP** - 8 data bits; 1 stop bit, no parity control
- 8d2SnP** - 8 data bits; 2 stop bits, no parity control
- 8d1SEp** - 8 data bits; 1 stop bit, EVEN parity control
- 8d1SoP** - 8 data bits; 1 stop bit, ODD parity control

Return to weighing:
See 12.2.2.

16. OTHER PARAMETERS

The user can set parameters which influence the scale operation. They are gathered in the submenu **<P5.other>** e.g. backlight and beep signal. Enter this submenu **<P5.other>** according to chapter 12.2.

16.1. Backlight function

Program recognizes the way the scale is supplied (mains, battery) and automatically selects the way of operating on the backlight:

- bl** – for mains,
- blbt** – for batteries or rechargeable battery pack.

16.1.1 Backlight for supplying from mains

Procedure:

- Enter the submenu **<P5.other>** and then:

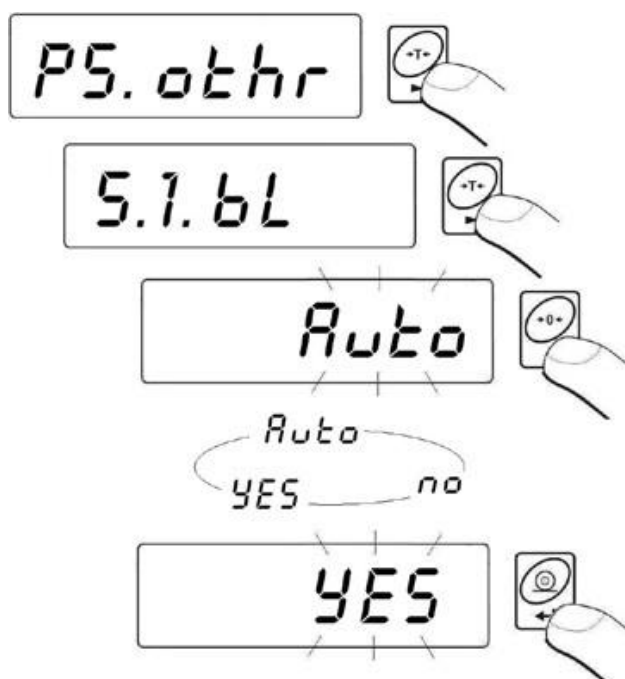

- bl no** - backlight switched off
- bl YES** - backlight switched on
- bl Auto** - backlight switched off automatically if indication becomes stable for about 10s

Return to weighing:
See 12.2.2.

Notice:

When bl=Auto, and the indication has not changed for 10s, the backlight is automatically switched off. The backlight is switched on again automatically after the result changes.

16.1.2. Backlight for supplying from batteries

The user can change the intensity of backlight from 0% to 100%. The lower the intensity is the longer the scale operates without recharging or exchanging batteries. When the intensity is set this function works as AUTO (described above).

Procedure:

- Enter the submenu **<P5.othr>** and then:

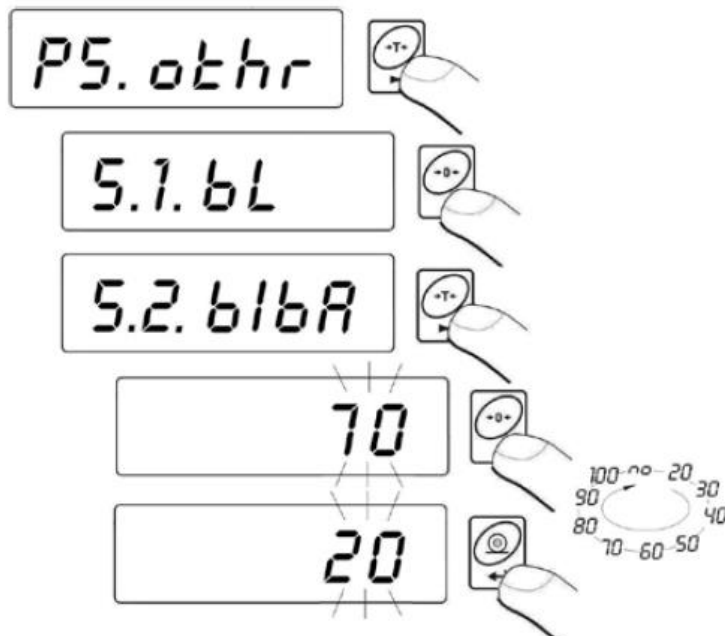

Return to weighing:

See 12.2.2.

Notice:

The more intense the backlight, the shorter the scale operates on batteries.

16.2. “Beep” signal – after pressing a key

Procedure:

- Enter the submenu **<P5.othr>** and then:

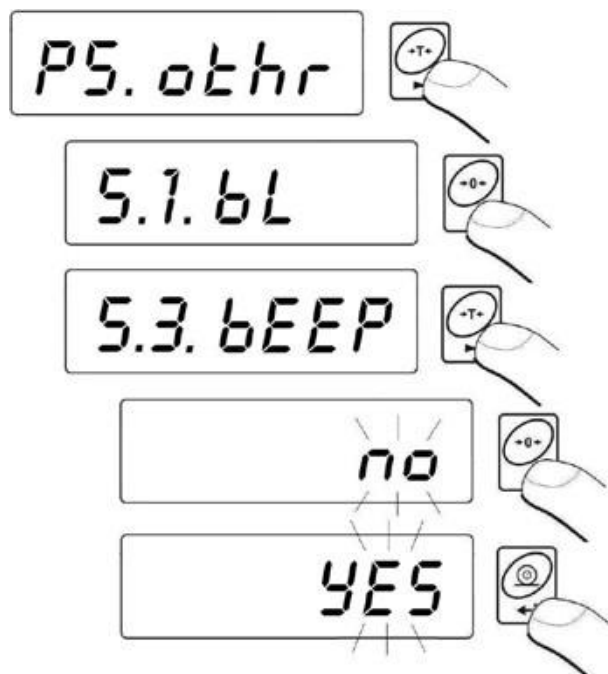

bEEP no - switched off
bEEP YES - switched on

Return to weighing:
 See 12.2.2.

16.3. Automatic switch-off

This function is essential to save battery power. The scale is switched off automatically when (function **t1 = YES**) no weighing appears in 5 minutes. (no changes on the display). In cases when this function disrupts the operation (e.g. long time weighing procedures) or while working with connection to mains, switch off this function.

Operation according to the power supply:

Setting	Operation	
	Mains	Batteries / accumulator
t1 = 0	disabled	disabled
t1 = YES	enabled	enabled
t1 = Auto *	disabled	enabled

* automatic enabling/disabling according to the source of power.

Procedure:

- Enter the submenu **<P5.othr>** and then:

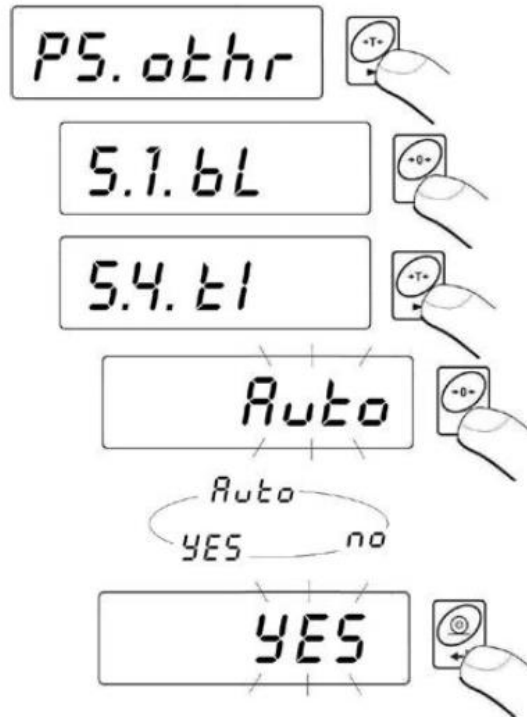

Return to weighing:
See 12.2.2.

16.4. Battery voltage level check

If supply from the batteries is at too low of a level of voltage, the pictogram  is displayed. It means that charging of batteries is required.

16.4.1. Checking the batteries

This function is to check the level of battery supply. It works only if:

- Weighing mode is set,
- Battery supply is set in parameters.

Procedure:

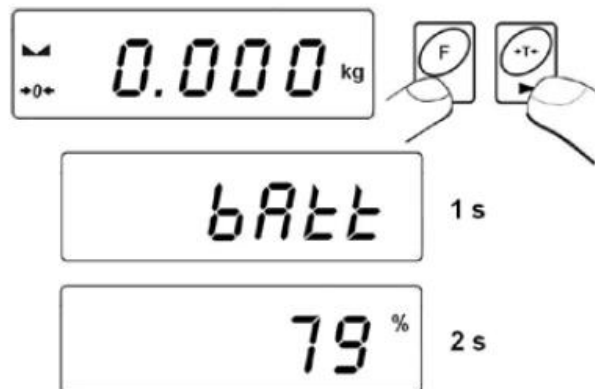



After displaying the level of batteries (in percent) the program returns to weighing.

16.4.2. Battery discharge pictogram

The symbol (bat low) switches on when the voltage level drops to 18% of the accepted level of voltage. It means that charging of batteries is required.

Low level of batteries:

-  pictogram on the display
- After some time the device will automatically switch off to protect the batteries from destructible discharging,
- Charging is signaled by  (blinking period about 2 seconds) on the display.



16.4.3. Accumulator charging option

This function allows to switch on charging algorithm for gel cell **SLA** accumulator:

a) Parameter **<CHR6>** set to **<no>**:

- Pictogram  does not appear, charging disabled,
- During software initializing, after turning on **<bAtt>**.

b) Parameter **<CHR6>** set to **<YES>**:

- Pictogram  blinks slowly (period about 2 seconds), charging is enabled,
- Message **<nImh>** appears on the display **<SLA>**,
- In case of damaging accumulators or lack of it the pictogram  blinks quickly (period about 0.5 sec).

Procedure:

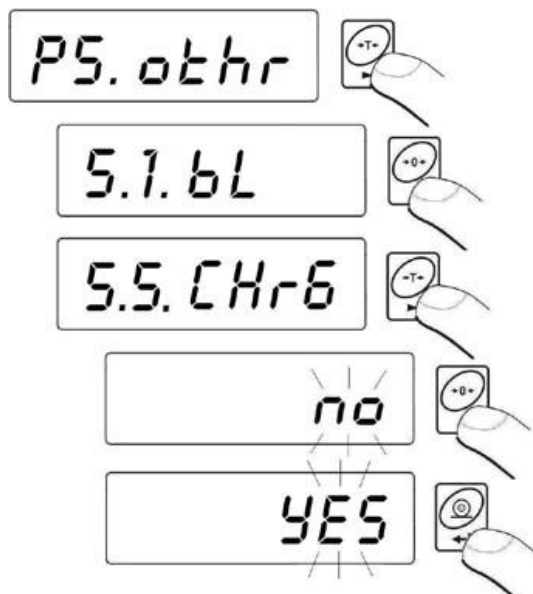

- Enter the submenu **<P5.othr>** and then:

CHR6 YES - enabled
CHR6 no - disabled

Return to weighing:
 See 12.2.2.

17. OPERATION MODES

17.1. Setting accessibility of operation modes

In this parameter group users can disable/enable accessibility of functions after

pressing  key.

Procedure:

- Enter the submenu **<P4.Func>** and then:

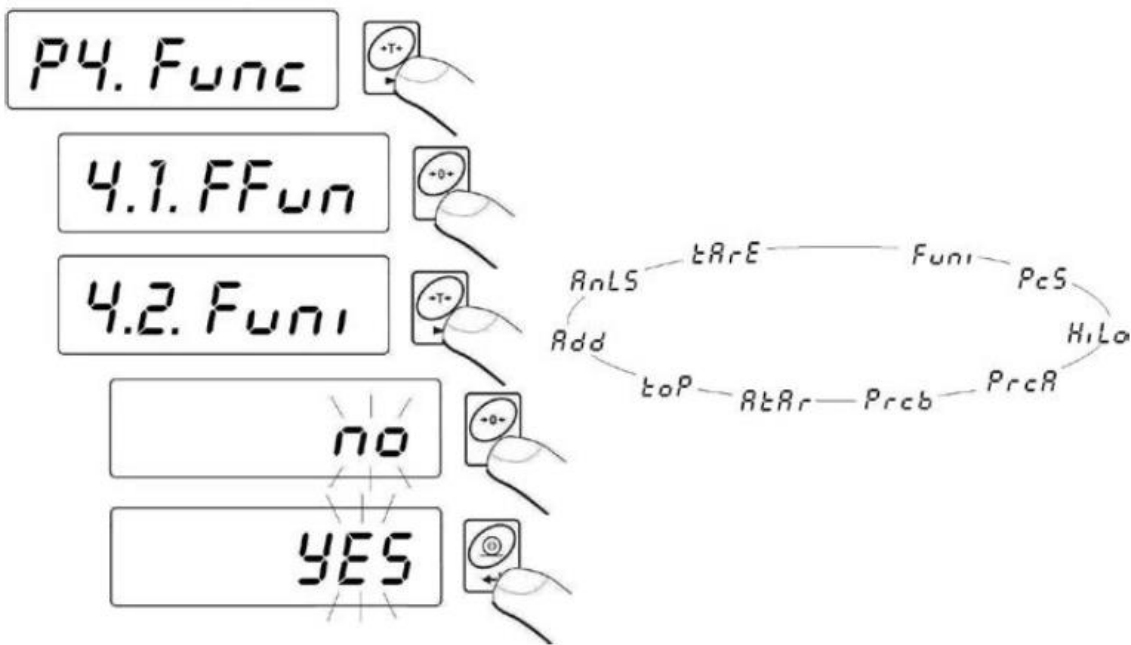

no - mode is disabled
YES - mode is enabled

Notice:

- Procedure for setting accessibility of other working modes is performed likewise.
- In order to make specified working modes accessible, press  key and set **<4.1. FFun>** parameter to value **<All>** (see point 16.2 of this manual).

Return to weighing:

See 12.2.2.

17.2. Selecting quantity of operation modes

This function enables user to set how many chosen and used by an

operator working modes are to be accessible after pressing  key, (**ALL**) or only one.

Procedure:

- Enter the submenu **<P4.Func>** and then:

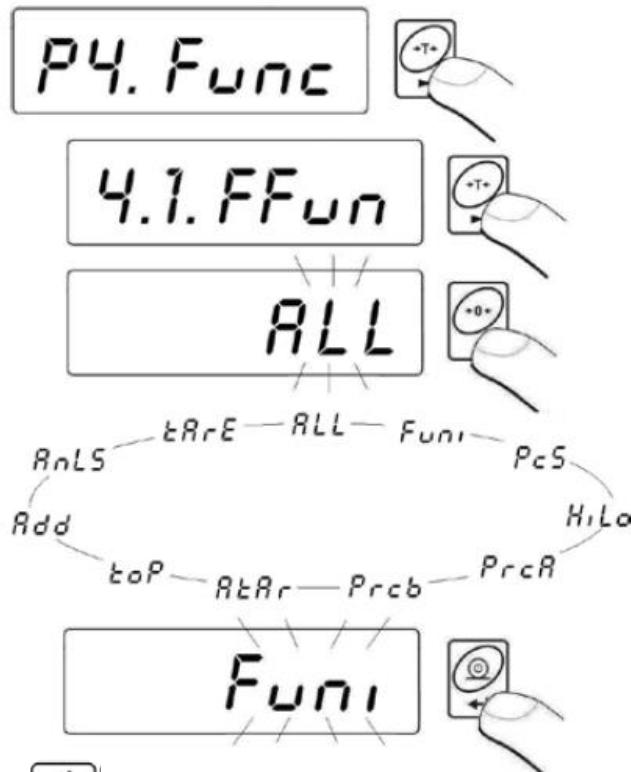

After choosing setting press  key. The program will return to displaying name of submenu **<P4.1.FFun>**.

Return to weighing:
See 12.2.2.

17.3. Counting pieces of the same mass

Standard solution is equipped with option of counting small pieces of the same mass. It is possible to execute a tare function in this operating mode in order to tare a container value.

Notice:

1. Counting pieces does not work together with other scale functions,

2. The counting pieces function is not saved as a default start function so it is not remembered after restarting.

Procedure:

- Enter to **<PcS>** function:

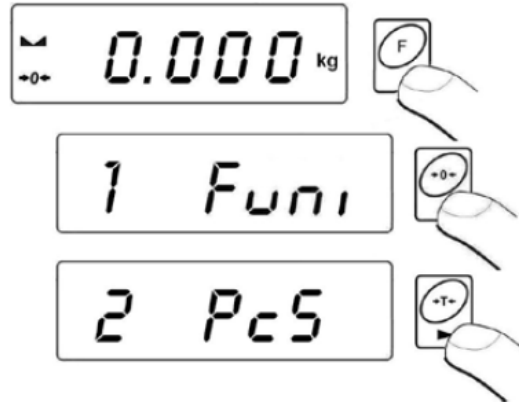

- You will see a blinking value of sample quantity.

- Press  key to start setting quantity of sample, you have a few options to choose from:

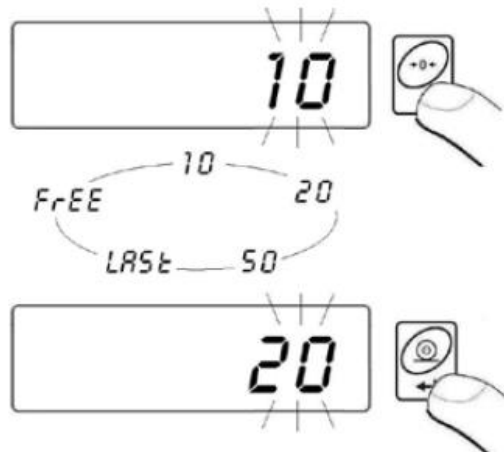

- If option **<LAST>** is chosen in the scale program displays estimated unit mass of the last piece (about 3 seconds) and then goes to **Counting pieces** automatically setting the previously displayed value as valid for the procedure.
- If the **<FrEE>** option is selected, you will see:



- Using and enter the required sample quantity, where: selection of digit position, - setting the digit,
- Confirm the value by pressing
- You will see **<LoAd>** on the display and then:

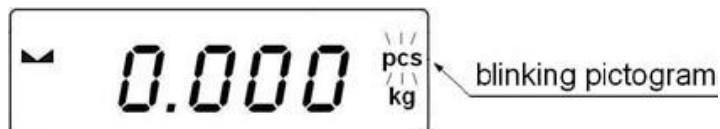

- If weighing is performed in a container put the container on the pan first and then tare it. Then put the declared quantity of pieces on the pan and confirm it when stable (signaled by):

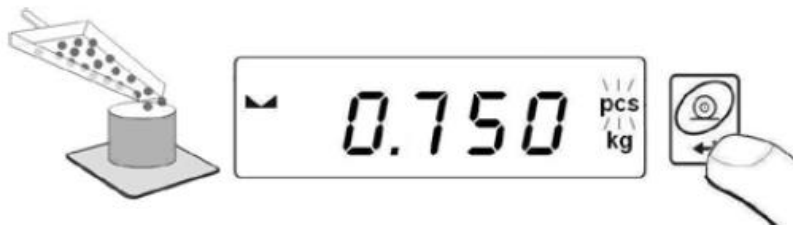

The program will automatically calculate the mass of a single piece and go on to the **Piece Counting** mode (**pcs**). You will see the following display:



Notice:

- If a user presses the key when load is not present on the pan, the message **-Lo-** will be indicated for a few seconds and the scale will automatically return to weighing.
- In order to comply with the rules of appropriate counting pieces put as many pieces as possible during unit mass adjustment. Single piece mass should not be less than 5 divisions.
- If a single piece mass is lower than a reading interval d the display will show the **<Err5>** message (see ch. 22. Error messages) and short audible signal will be emitted than the scale returns to weighing.

Return to weighing:

- Press the key twice.

17.4. +/- control referring to the inscribed standard mass Procedure:

- Enter to <HiLo> function:

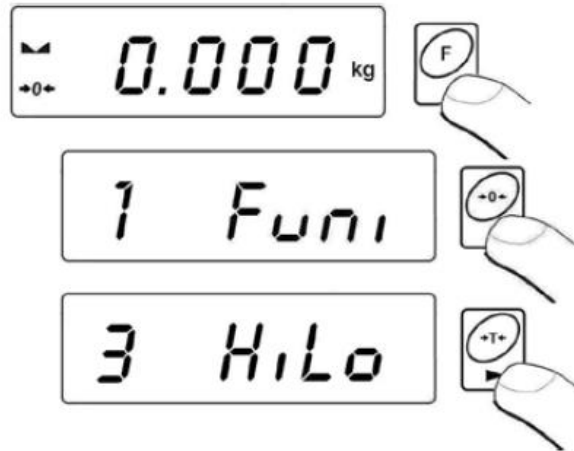

- The program enters the window of setting the lower threshold of weighing (**Min**):

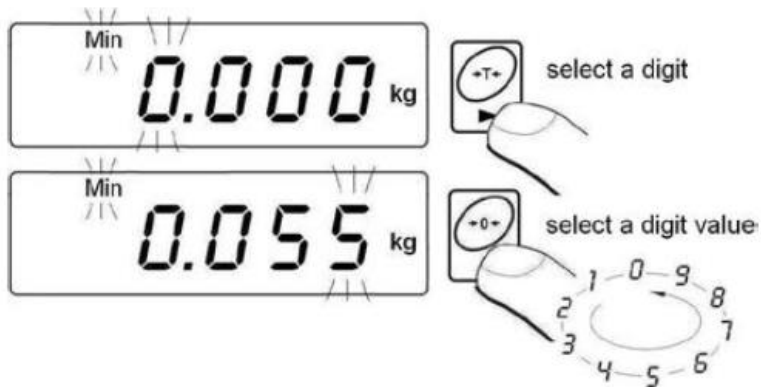

- The inscribed value is confirmed by pressing , the program will automatically go to the higher threshold of weighing (**Max**):

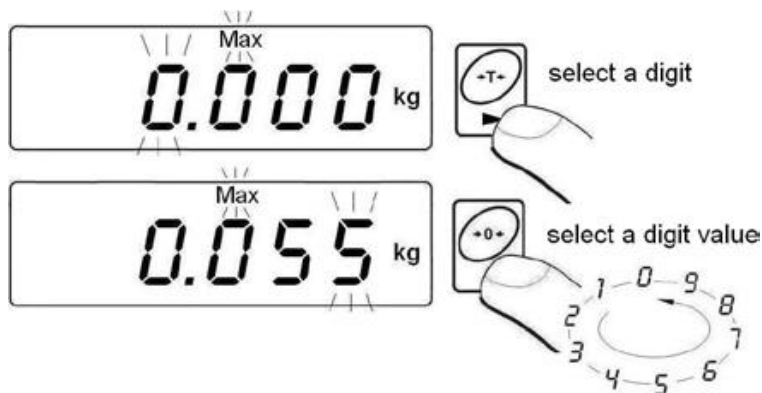

- The inscribed value confirm by pressing  , the program will automatically go to the main window.
- During setting threshold values following cases take place:

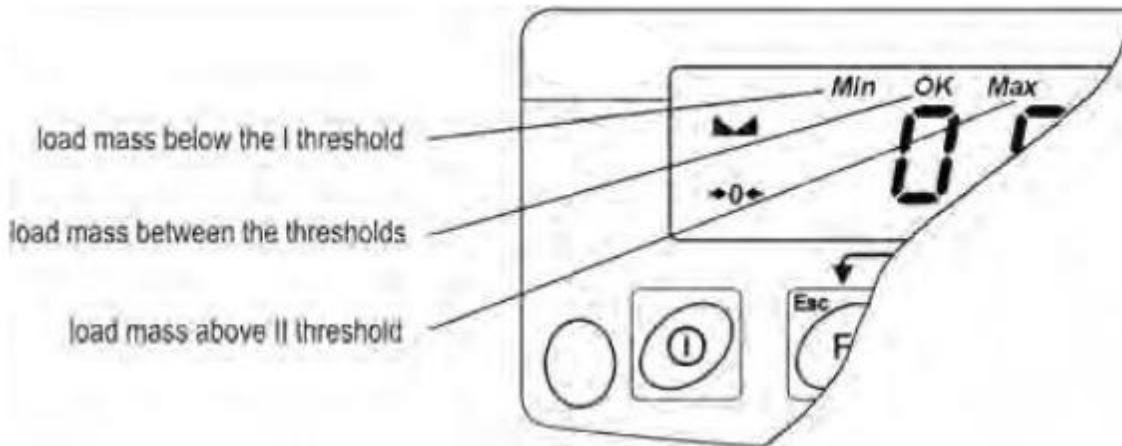

Notice:

If a user erroneously enters a value of the lower threshold higher than the upper one, the scale will indicate an error message and will return to weighing.

Return to weighing:

- Press the  key twice.

17.5. Control of % deviation referring to the inscribed standard mass

Scale software enables control of deviation (in %) of weighed loads mass referring to the inscribed standard mass. Mass of standard can be determined by its weighing (**PrcA** function) or entered to the scale memory by an user (**PrcB** function).

17.5.1. Standard mass determined by its weighing

Procedure

- Enter to **<PrcA>** function:



- You will see **<LoAd>** on the display and then:



- place an load on the pan which mass will be accepted as standard
- press  to confirm this operating mode
- after few seconds the indication **100,00%** will be displayed
- From this moment display will not indicate mass of weighed load but deviation of load mass placed on the pan referring to the mass of standard (in %).



Return to weighing:

- Press the  key twice.

17.5.2. Mass of standard inscribed to scale memory

Procedure:

- Enter to **<PrcB>** function:



- The program goes to the weight display window:



- Using and set **standard mass**, where: - digit selection, - digit setting.
- Confirm the entered value by pressing .
- You will see the indication equal to **0,000%**,
- From this moment display will not indicate the mass of weighed load but deviation of the load mass placed on the pan referring mass of standard (in %).

Return to weighing:

- Press the key twice.

17.6. Automatic tare

This function is useful for fast net mass determination of weighed load in case when tare value of is different for each load. In case when the function is active the cycle of scales operating looks as follows:

- press zeroing key when the pan is empty,
- place the container for pieces,
- when indication is stable **automatic taring** of the container mass will be performed (**Net** marker will appear in the upper part of the display),
- place a sample into the package,
- display will indicate net mass of sample,
- remove the sample together with the container,
- display will indicate tare mass with minus sign,
- place a container for the next sample. When indication is stable automatic tarring will take place (**Net** marker will appear in the upper part of the display),
- place next sample into the package.

Procedure:

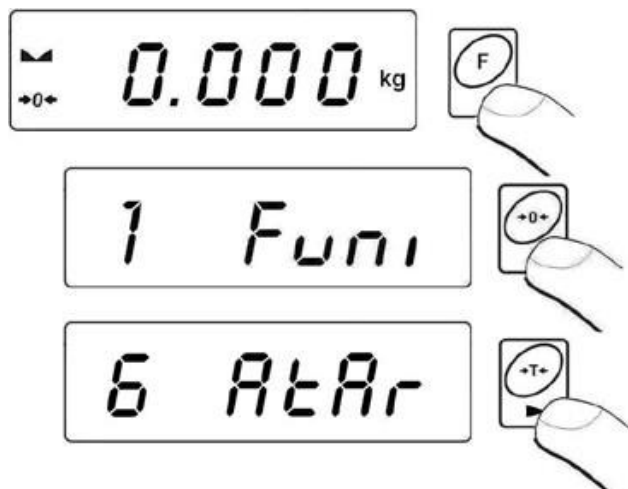

Return to weighing:

- Press the  key twice.

17.7. Measurement of maximal force on the pan –latch

Procedure:

- Enter to **<toP>** function:

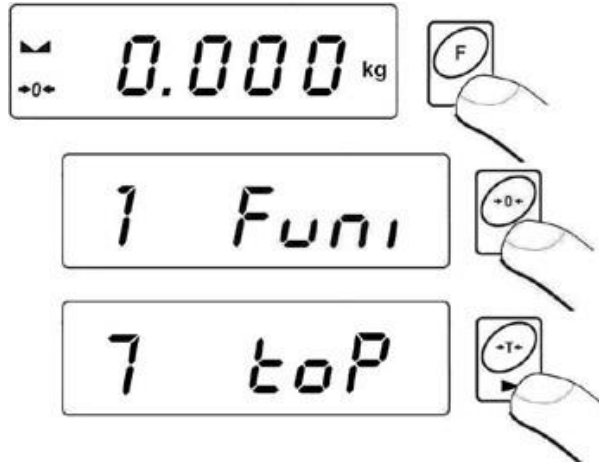

- Confirmation of choice of **<toP>** function is indication of the **Max** pictogram:



- Apply a force to the weighing pan,
- The display of scale will latch the maximum value of the force,
- Remove loads from the pan,

- Before the next measurement press the  key.

Return to weighing:

- Press the  key twice.

17.8. Totalizing

Scale software is equipped in a totalizing function of single weighing's. The totalizing procedure can be documented on the printer connected to the indicator.

17.8.1. Enabling the work mode

Procedure:

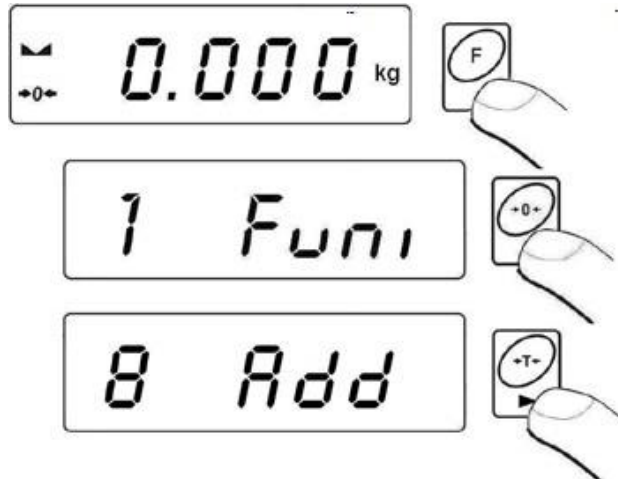

- Enter to **<Add>** function:





- A letter **"P"** in the left side of the display is a confirmation that **<Add>** function have been selected:

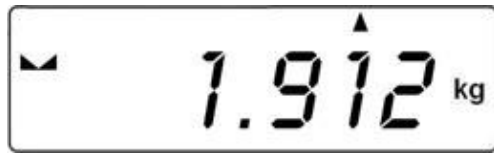

17.8.2. Totalizing procedure

- Enter **<Add>** function according to ch. 17.8.1,
- Put the first load on the pan. If the weighing procedure is performed in a container put the container on the pan first and tare it. Then put the first load on the pan and confirm it by pressing  when stable (signaled by ),
- You will see a sum of weighing's on the display, the **"▲"** pictogram in the upper right corner will be displayed and the weighing result will be printed on the printer connected to the indicator.





- Take off the load from the pan, indication returns to **ZERO** and the letter “**P**” in the left part of the display appears,
- Put the next load on the pan,
- After stabilizing press , the sum of first and second weighing will appear on the display, the “▲” pictogram in the upper right corner will be displayed and the second weighing result will be printed on the printer connected to the indicator:



- Press  to complete the procedure (with the loaded or unloaded pan), a sum of all weighing's will be printed:





(1) 1.912 kg
(2) 1.912 kg
----- TOTAL: 3.824 kg

- In case of pressing  one more time with loaded pan, you will see the **<unLoAd>** message. Unload the pan, the scale will return to **ZERO** and the letter “**P**” in the left part of the display will appear. The scale is ready for the next procedure.
- In case of pressing  one more time with loaded pan, you will see the letter “**P**” in the left part of the display will appear. The scale is ready for the next procedure.

17.8.3. Memory of the last value of sum of weighed goods

After interrupting (e.g. switching off) the totalizing procedure, it is possible to restart the procedure without losing data. In order to do it just enter the totalizing procedure:



- Enter **<Add>** function again according to the ch.17.8.1 of the manual,
- You will see the last memorized sum of weighings on the display

- In order to continue the procedure press , the indication returns to **ZERO** and the letter **"P"** appears in the left part of the display. The scale is ready for weighing,
- In order to terminate the previous totalizing procedure press  key, , or . You will see the letter **"P"** in the left part of the display. The scale is ready for weighing.



17.8.4. Return to weighing

- Press  key, you will see:



- Before leaving the **<Add>** function it is possible to print out subsequent weighings and the sum of weighings on the connected printer (press  to print, press  to cancel).
- The following message will appear on the display:



- Press  key to return to weighing,
- Press  to return to totalizing.

Notice:

In case of overflow of the range of the display in totalizing you will see

<5-FULL> message in the display. In that case unload the pan and press  to complete the procedure with a printout of sum of all weighings or put a lower mass on the pan which does not cause the overflow error.

17.9. Weighing animals

Procedure:

- Enter to **<AnLS>** function:



- The **<tinnE>** message appears on the display for **1s**, and then the program goes to the window of setting the duration time (in seconds) of the animal weighing process:

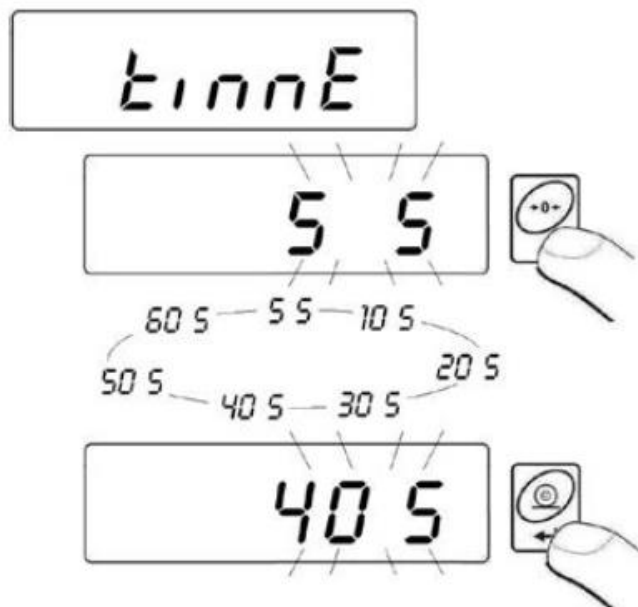

- Confirm the selected value by pressing  ,
- You will see the following window:



- Load an animal to the platform,
- After exceeding the **-LO-** value (see 15.2), program starts the weighings process. The appearance of subsequent hyphens <-----> showing the progress,
- After completing the process of weighings the result is latched on the display and additionally the **OK** pictogram is shown in the upper part of the display:



- You can start the procedure of weighing animals again by pressing ,
- After removing the animal from the platform program returns to the window:



Return to weighing:

- Press  .

17.10. Tare memory

Users are allowed to Enter Up to 9 tare values to the memory.

17.10.1. Entering the tare value to the scale memory

Procedure:

- Enter to <tArE>function:

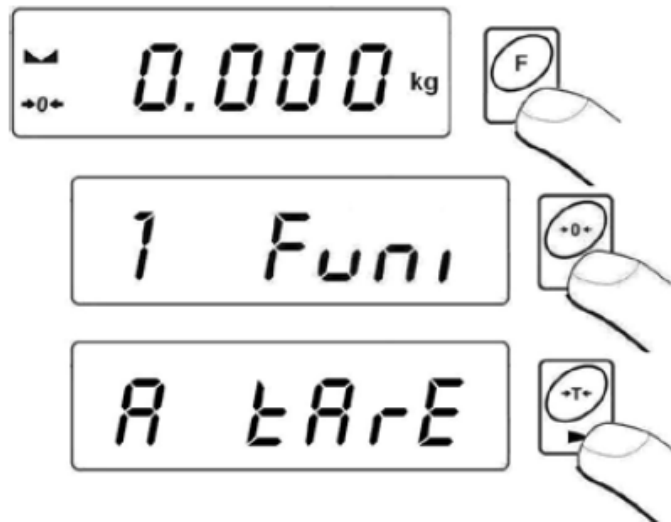

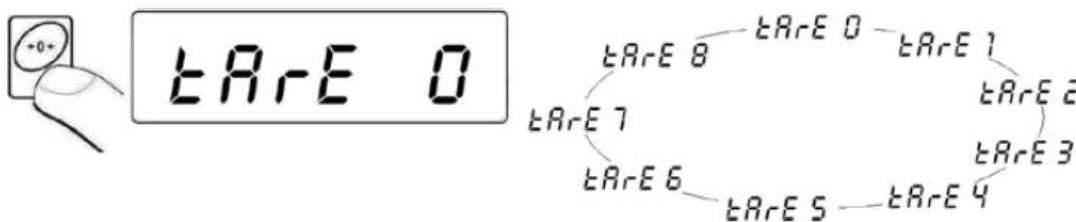

- The program goes to displaying the first value from the selection of tare values <tArE 0>

(press  to choose different values):

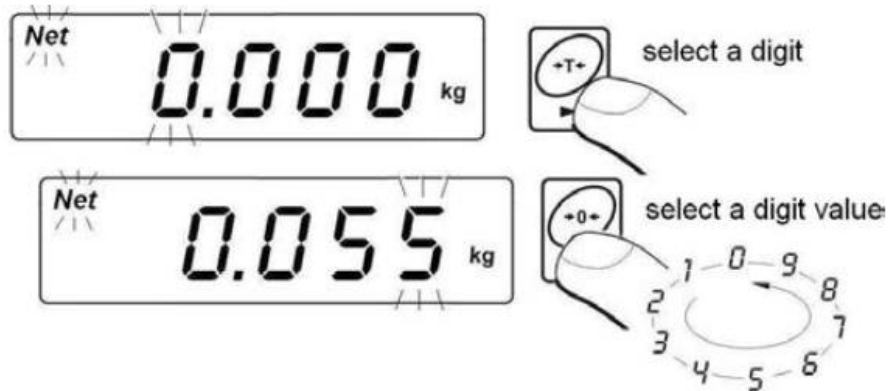

- After selecting the right position press  and you will see an editing field:



- Enter the selected **tare value** to the scale ,
- The program returns to the following window:

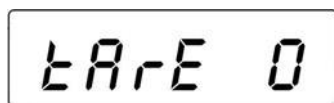

Return to weighing:

- Press .

17.10.2. Selecting a tare value from the memory

- Enter **<tArE>** function according to the ch. 17.10.1 of the manual,
- The program goes to displaying the first value from the selection of tare values **<tArE 0>**

(press  to choose different values):

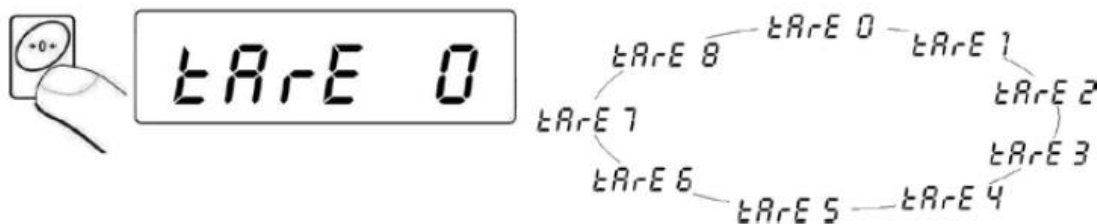

- To use an entered tare value press , you will see the tare value on the display preceded by the “-” sign and the **Net** pictogram:



Caution:

A tare value from the memory is not remembered after powering off and on the scale.

18. SCALE CALIBRATION

In precise scales changes of gravitational acceleration have noticeable influence. The gravitational acceleration changes with altitude and latitude. Every scale has to be adjusted to the place of use especially when the place changes. Frequent calibration also prevents weighing process from the influence of humidity and temperature.

For assuring the maximal accuracy of weighing a periodical user calibration is required.

Calibration should be performed:

- Before weighing process,
- After a long break between series of measurements,
- After the ambient temperature change.

Conditions of triggering calibration:

- Calibration with an external weight.

Caution:

*It should be remembered that the calibration process should be performed with the empty pan! The calibration process can be terminated by pressing **Esc** when necessary.*

Procedure:

- Enter submenu **<P6.CAL>** and then:

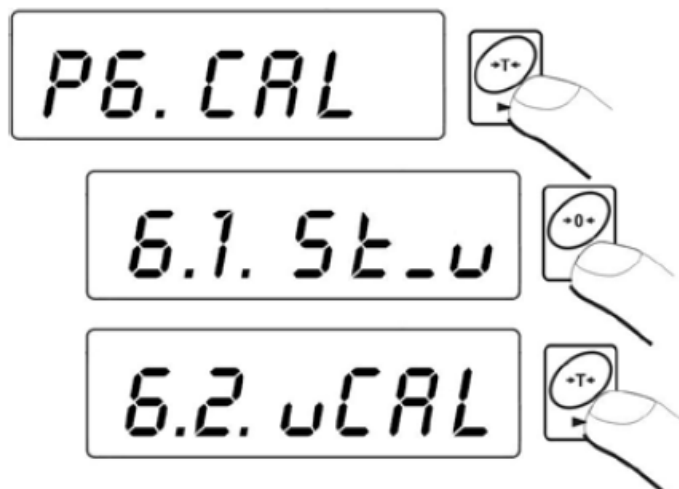

- Following messages will be displayed:



- During this time start mass is adjusted, and after completing the procedure calibration weight mass is displayed (e.g. **3.000kg**),
- Place the required weight on the pan,
- Calibration process starts automatically after placing the adequate weight that is signaled by the following message:



- The completion of the calibration procedure is signaled by the following message:



- Take off the weight from the pan, the message **<donE>** is displayed for 1s and the program returns to the calibration submenu:

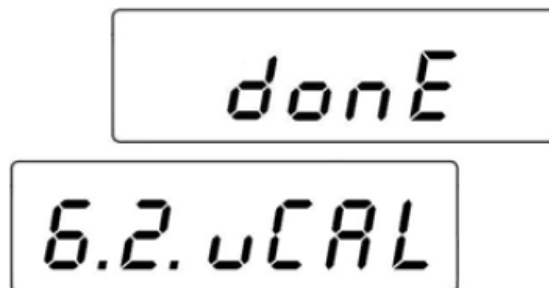

- Calibration process can be terminated anytime by pressing  which is signaled by the following message on the display:



- Return to weighing with saving changes that have been made.

Caution:

If the calibration process (span adjustment) lasts longer than 15 the

<Err8> message will be displayed and short audible signal will be emitted. Press  to perform calibration again with more stable ambient conditions!

19. COOPERATION WITH PRINTER

Each time the  key is pressed a current mass value together with mass units is sent to RS 232 interface.

Depending on setting of **STAB** parameter it can be printed out with temporary or stable value. Depending on setting of **REPL** parameter, printout will be automatic or manual.

Cable diagrams:

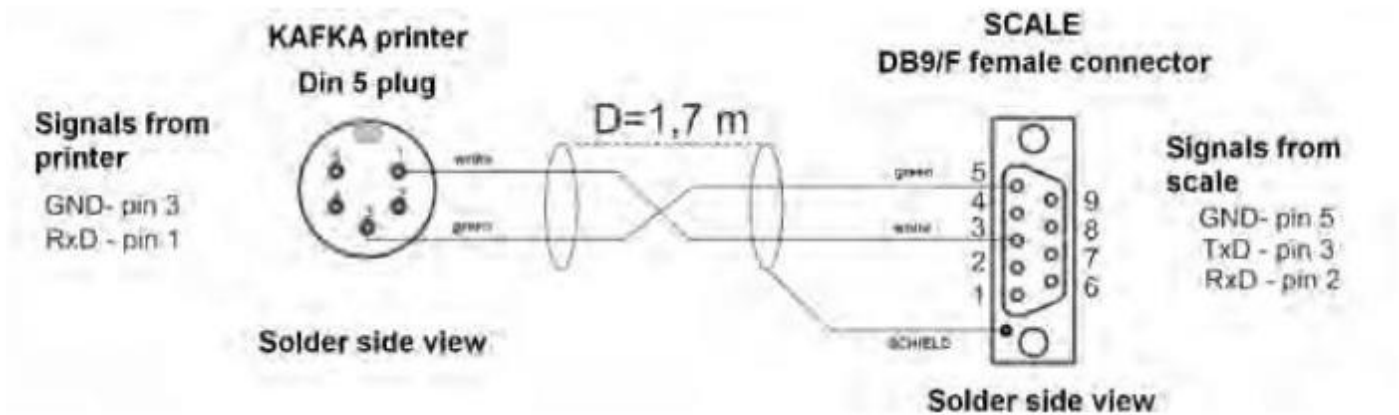

Scale –printer cable diagram

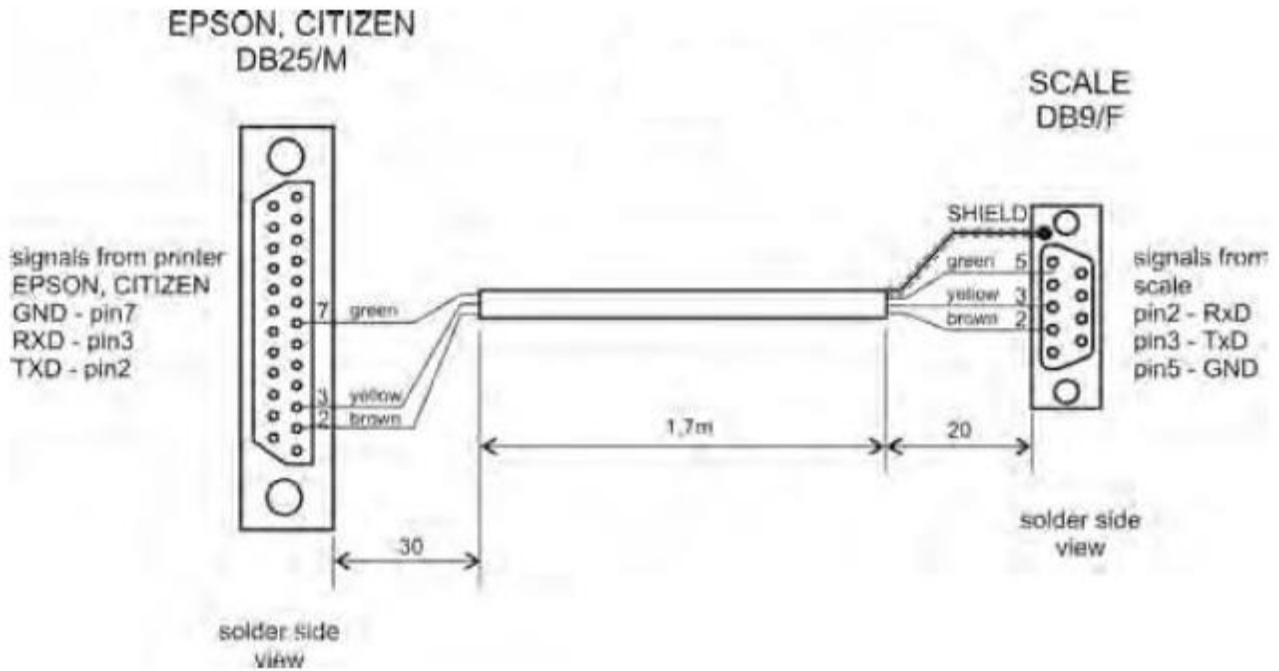

Scale – EPSON printer cable diagram

20. COOPERATION WITH COMPUTER

Sending weighing results to the computer can be done:

- manually
- in continuous way
- automatically
- on the request from the computer
- after pressing  key,
- after function activating or sending an appropriate command,
- After stabilizing the indication
- After sending a control command

Cable diagrams:

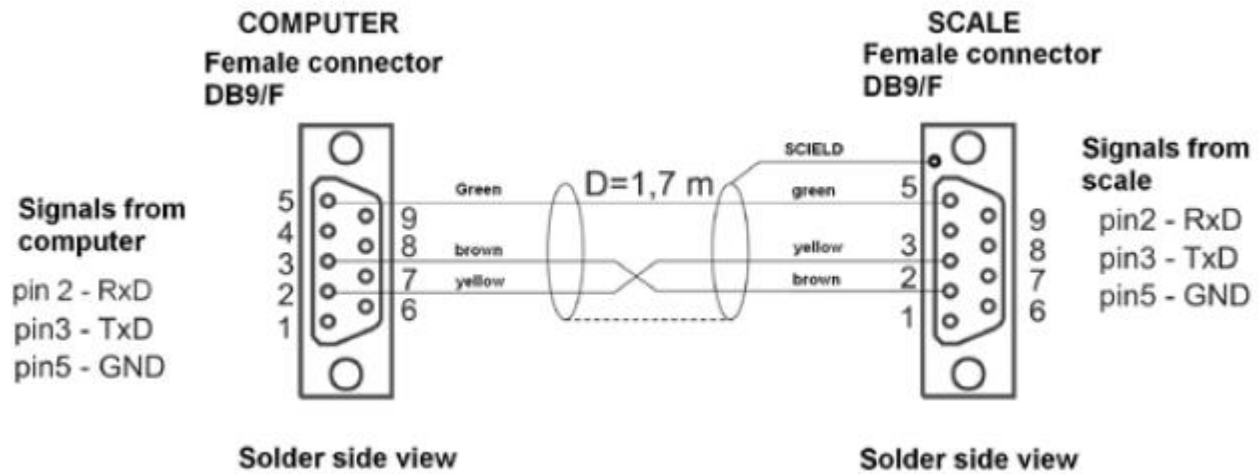

Scale – computer cable diagram

21. COMMUNICATION PROTOCOL

21.1. General information

- A. A character protocol scale-terminal has been designed for communication between the scale and external devices via RS-232 interface.
- B. It consists of commands sent from an external device to the scale and a response from a scale.
- C. Responses are sent every time after receiving a command (reaction for any command).
- D. Using commands allows users to receive some information about the state of scale and/or influence the operation e.g.: requesting weighing results, display control.

21.2. A set of commands for RS interfaces

Commands	Description of commands
Z	Zeroing
T	Tarring
OT	Get tare
UT	Set tare
S	Send the stable result in basic unit
SI	Send the result immediately in basic unit
SU	Send the stable result in current unit
SUI	Send the result immediately in current unit
C1	Switch on continuous transmission in basic unit
C0	Switch off continuous transmission in basic unit
CU1	Switch on continuous transmission in current unit
CU0	Switch off continuous transmission in current unit
K1	Lock the scale keyboard
K0	Unlock the scale keyboard
NB	Give serial number
PC	Send all implemented commands

Notice:

1. Each command have to be terminated in CR LF;
2. The best Policy for communication is not sending another command until the former answer has been received.

21.3. Respond message format

After sending a request message you can receive:

XX A CR LF	command accepted and in progress
XX D CR LF	command completed (appears only after XX_A)
XX I CR LF	command comprehended but cannot be executed
XX _ ^ CR LF	command comprehended but time overflow error appeared
XX _ v CR LF	command comprehended but the indication below the
XX _ OK CR LF	Command done
ES CR LF	Command not comprehended
XX _ E CR LF	error while executing command – time limit for stable result exceeded (limit time is a descriptive parameter of the scale)

XX - command name
 _ - substitutes spaces

21.4. Command's description

21.4.1. Zeroing

Syntax **Z CR LF**

Possible answers:

- Z_A CR LF** - command accepted and in progress
- Z_D CR LF** - command completed
- Z_A CR LF** - command accepted and in progress
- Z_^ CR LF** - command comprehended but zero range overflow appeared
- Z_A CR LF** - command accepted and in progress
- Z_E CR LF** - time limit for stable result exceeded
- Z_I CR LF** - command comprehended but cannot be executed

21.4.2. Tarring

Possible answers

- T_A CR LF** - command accepted and in progress
- T_D CR LF** - command completed
- T_A CR LF** - command accepted and in progress
- T_v CR LF** - command comprehended but tare range overflow appeared
- T_A CR LF** - command accepted and in progress
- T_E CR LF** - time limit for stable result exceeded
- T_I CR LF** - command comprehended but cannot be executed

21.4.3. Get tare value

Syntax: **OT CR LF**

Possible answers:

- OT_TARA CR LF** - command executed

Frame format:

1	2	3	4	5-6	7-15	16	17	18	19	20	21
T	O	space	stability	space	tare	space	unit			CR	LF

- Tare** - 9 characters with decimal point justified to the right
- Unit** - 3 characters justified to the left

21.4.4. Set tare value

Syntax: **UT_TARE CR LF**, where **TARE** – tare value

Possible answers:

UT_OK CR LF - command executed

UT_I CR LF - command comprehended but cannot be executed

ES CR LF - command not recognized (possible wrong tare format)

Notice:

This protocol uses the dot character as a decimal point for separating the decimal fraction part.

21.4.5. Send the stable result in basic unit

Syntax: **S CR LF**

Possible answers:

S_A CR LF - command accepted and in progress

S_E CR LF - time limit for stable result exceeded

S_I CR LF - command comprehended but cannot be executed

S_A CR LF - command accepted and in progress

MASS FRAME - mass value in basic unit is returned

Frame format:

1	2-3	4	5	6	7-15	16	17	18	19	20	21
S	space	stability	space	sign	mass	space	unit			CR	LF

Example:

S CR LF – computer command

S_A CR LF - command accepted and in progress

S _ _ _ _ - _ _ _ _ _ 8 . 5 _ g _ _ CR LF – command done, mass value in basic unit is returned.

21.4.6. Send the result immediately in basic unit

Syntax: **SI CR LF**

Possible answers:

SI_I CR LF - command comprehended but cannot be executed at the moment

MASS FRAME - mass value in basic unit is returned

Frame format:

1	2	3	4	5	6	7-15	16	17	18	19	20	21
S	I	space	stability	space	sign	mass	space	unit			CR	LF

Example:

S I CR LF – computer command

S I _ ? _ _ _ _ _ 1 8 . 5 _ k g _ CR LF - command done, mass value in basic unit is returned immediately.

21.4.7. Send the stable result in current unit

Syntax: **SU CR LF**

Possible answers:

SU_A CR LF - command accepted and in progress
SU_E CR LF - timeout while waiting for stable results

SU_I CR LF - command comprehended but cannot be executed

SU_A CR LF - command accepted and in progress
MASS FRAME - mass value in current unit is returned

Frame format:

1	2	3	4	5	6	7-15	16	17	18	19	20	21
S	U	space	stability	space	sign	mass	space	unit			CR	LF

Example:

S U CR LF – computer command

S U _ A CR LF - command accepted and in progress

S U _ _ _ - _ _ 1 7 2 . 1 3 5 _ N _ _ CR LF - command done, mass value in current unit is returned.

21.4.8. Send the result immediately in current unit

Syntax: **SUI CR LF**

Possible answers:

SUI CR LF - command comprehended but cannot be executed

MASS FRAME - mass value in current unit is returned immediately

Frame format:

1	2	3	4	5	6	7-15	16	17	18	19	20	21
S	U	I	stabilit	space	sign	mass	space	unit			CR	LF

Example:

SUI CR LF – computer command

SUI? _ - _ _ _ 5 8 . 2 3 7 _ k g _ CR LF - command executed and mass returned

21.4.9. Switch on continuous transmission in basic unit

Syntax: **C1 CR LF**

Possible answers:

C1_I CR LF - command comprehended but cannot be executed

C1_A CR LF - command comprehended and in progress

MASS FRAME - mass value in basic unit is returned

Frame format:

1	2	3	4	5	6	7-15	16	17	18	19	20	21
S	I	space	stability	space	sign	mass	space	unit			CR	LF

21.4.10. Switch off continuous transmission in basic unit

Syntax: **C0 CR LF**

Possible answers:

C0_I CR LF - command comprehended but cannot be executed

C0_A CR LF - command comprehended and executed

21.4.11. Switch on continuous transmission in current unit

Syntax: **CU1 CR LF**

Possible answers:

CU1_I CR LF - command comprehended but cannot be executed

CU1_A CR LF - command comprehended and in progress
MASS FRAME - mass value in current unit is returned

Frame format:

1	2	3	4	5	6	7-15	16	17	18	19	20	21
S	U	I	stability	space	sign	mass	space	unit			CR	LF

21.4.12. Switch off continuous transmission in current unit

Syntax: **CU0 CR LF**

Possible answers:

CU0_I CR LF - command comprehended but cannot be executed

CU0_A CR LF - command comprehended and executed

21.4.13. Lock the scale keyboard

Syntax: **K1 CR LF**

Possible answers:

K1_I CR LF - command comprehended but cannot be executed

K1_OK CR LF - command executed

Caution:

This command is not remembered after restart

21.4.14. Unlock the scale keyboard

Syntax: **K0 CR LF**

Possible answers: **K0_OK CR LF** – command in progress

21.4.15. Give serial number

Syntax: **NB CR LF**

Possible answers:

NB_A "Factory number" CR LF - command comprehended, scale serial number is given in return

NB_I CR LF - command comprehended but cannot be executed

"Factory number" – parameter specifying scales serial number, it is returned in between inverted commas.

Example:

NB CR LF – command from a computer

NB_A "123456" CR LF – scales serial number - 123456

21.4.16. Send all implemented commands

Syntax: **PC CR LF**

Possible answers:

PC _->_Z,T,S,SI,SU,SUI,C1,C0,CU1,CU0,K1,K0,OT,UT,NB,PC

– command executed, the indicator have sent all the implemented commands.

21.5. Manual printouts / automatic printouts

Users can general manual or automatic printouts from the scale.

- Manual printouts can be performed after loading the pan and stabilizing indication by

pressing  .

- Automatic printouts can be performed only after loading the pan and stabilizing indication.

Notice:

If a scale is verified printouts of immediate values are blocked.

Format frame:

1	2	3	4 -12	13	1	1	16	17	18
stability	space	sign	mass	space	unit		CR	LF	

Stability character [space] if stable [?] if not stable
 [^] if an indication over the range
 [v] if fan indication below the range

sign [space] for positive values or [-] for negative values

mass 9 characters justified to the right

unit 3 characters justified to the left

command 3 characters justified to the left

Example 1:

____ 1 8 3 2 . 0 _ g _ _ CR LF – the printout generated from the scale after pressing ENTER/PRINT.

Example 2:

? _ - ____ 2 . 2 3 7 _ l b _ CR LF - the printout generated from the scale after pressing ENTER/PRINT.

Example 3:

^ ____ 0 . 0 0 0 _ k g _ CR LF - the printout generated from the scale after pressing ENTER/PRINT.

21.6. Continuous transmission

The indicator can work in a continuous transmission mode. It can be switched on or off in parameters or using RS232 commands.

The frame format sent by the indicator in case of setting <P2.Prnt> to **CntA**:

1	2	3	4	5	6	7-15	16	17	18	19	20	21
S	l	space	stability	space	sign	mass	space	Unit			CR	LF

Stability character [space] if stable [?] if not stable
 [^] if an indication over the range
 [v] if fan indication below the range

sign [space] for positive values or [-] for negative values

mass 9 characters justified to the right

unit 3 characters justified to the left

command 3 characters justified to the left

The frame format sent by the indicator in case of setting <P2.Prnt> to Cntb:

1	2	3	4	5	6	7-15	16	17	18	19	20	21
S	U	I	stability	space	sign	mass	space	unit			CR	LF

22. ERROR COMMANDS

- Err2** - Value beyond the zero range
- Err3** - Value beyond the tare range
- Err4** - Calibration mass or start mass beyond the acceptable range ($\pm 1\%$ for weight, ± 10 for start mass)
- Err5** - Mass of a single piece lower than the scale division
- Err8** - Exceeded the time for tarring, zeroing, start mass adjustment or span adjustment
- Err9** - Time for internal weight lifting/dropping down exceeded
- NULL** - Zero value from the AD converter
- FULL2** - Measurement range overflow
- LH** - Start mass error, the mass on the weighing platform is beyond the acceptable range (-5% to +15% of start mass)
- 5-FULL** - Display range overflow in totalizing

Notice:

1. Errors: **Err2, Err3, Err4, Err5, Err8, Err9, null**, that appear on the display are also signaled by a short beep sound (about 1 sec.);
2. Error **FULL2** that appears on the display is also signaled by a continuous sound until the cause of error disappears.

23. TROUBLE SHOOTING

Problem	Cause	Solution
Turning on does not work	Discharged batteries.	Connect to mains or change batteries
	No batteries (not installed or improperly installed)	Check the correctness of installation (polarization)
The scale turns off automatically	"t1" set to "YES" (Power save)	In "othr" submenu change "5.4 t1" to "no"
After turning on "LH" message on the display	Loaded weight pan during powering up	Unload the pan. Then the scale will indicator zero.

