

Filtered Universal Fit Pipette Tips

10, 20, 200, 1000 µL

As per the manufacturer, the below products meet the following criteria:

Catalog Number	PC01-04-01, PC01-05-01, PC01-07-01, PC01-04-03, PC01-05-03, PC01-06-03, PC01-07-03
European Article Number	NA
Lot Number	#21002
Description	50 boxes of pipette tip boxes (1000 µL available in 40 or 50)
Date of Expiration	3 Years after sterilization

Quality system compliance

The product conforms to written material specifications and was manufactured under the manufacturer's registered and audited ISO-9001 quality system, and underwent lot testing as outlined in the manufacturer's laboratory procedures. These products come with the highest standard of quality assurance.

QC testing

Each item was produced in a tightly controlled environment and subjected to the manufacturer's rigorous testing and performance procedures. The products meet all stated standards for precision, clarity, warp, and freedom from contamination.

Product specifications

Material:	Tip Material & Pipette Tip Box Material: Polypropylene Free of cytotoxic effects. Plastic resins used in product manufacturing have been tested using prescribed USP methods for cytotoxicity <i>in vitro</i> .
Non-Pyrogenic Statement:	Product samples are exposed to endotoxin-free water and the resulting extraction fluids are tested for contamination using kinetic turbidimetric Limulus Amoebocyte Lysate (LAL) assay protocol and USP guidelines. All products tested must display less than 0.05 EU/mL to be certified free of endotoxin.
DNase & RNase Free:	Product samples were subjected to testing using DNase Alert QC System Fluorometric DNase Detection Assay Kit Ref# AM1970 and RNase Alert QC System Fluorometric RNase Detection Assay Kit Ref# AM1966. Endpoint method was used for detection and the instructions provided on the kit manual were followed for testing. Test samples were measured at the same gain setting as for the minus-DNase control and minus-RNase control. Solutions which have 2–3 fold more fluorescence than the negative control should be considered DNase or RNase contaminated.
Latex Statement:	No Latex was used in the manufacturing of the product. This also includes all the packaging and shipping materials used in the production of all items. The only time the product or packaging may come in contact with Latex would be from the Latex gloves that production employees are required to wear for the purpose of clean handling and to avoid biological contamination of the products.
Autoclavable:	Yes
Sterility:	Sterilization by electron beam. Catalog numbers ending in 01 are sterilized by gamma irradiation.

Filtered Universal Fit Pipette Tips

10, 20, 200, 1000 μ L

Bio Contamination Testing

Tips considered "pre-sterile" undergo an irradiation or electron beam treatment process to destroy microorganisms, nucleic acids and other potential biological contaminants. The treatment process is accompanied by regular bioburden tests to validate a minimum SAL level of 10^{-3} .

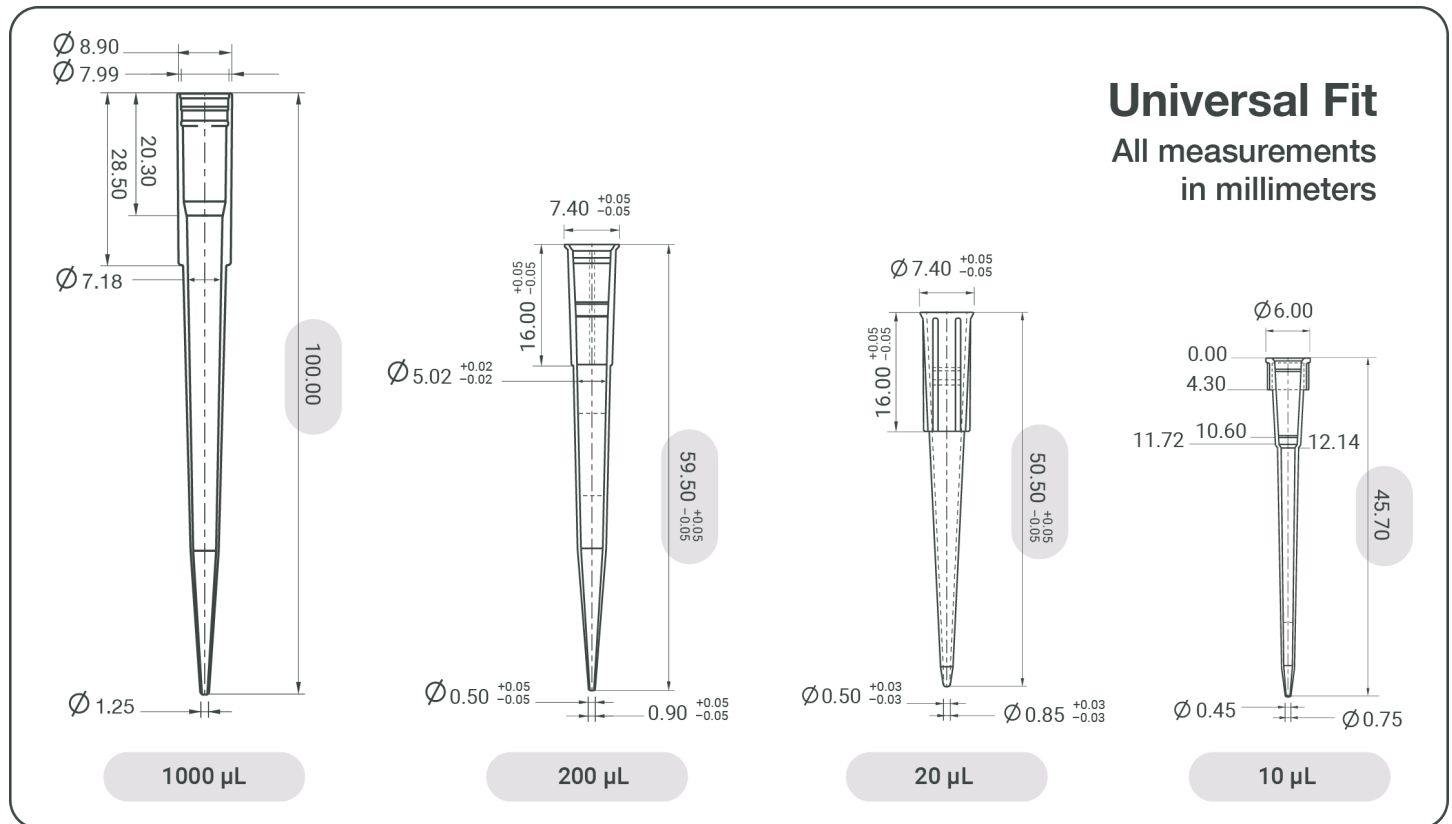

Signed

James O'Brien
CEO
Polycarbin, Inc.