

FR141WWW/0HC

Product Data Sheet

14 Cu. Ft. General Purpose Flammable Material Storage Refrigerator

Images



Product Description

Flammable storage refrigerators meet the requirements of NFPA 45 and NFPA 30 for cold storage of flammable and combustible materials in unclassified laboratory locations. Utilizes non-sparking and/or ATEX rated components to ensure an intrinsically safe interior for flammable materials in sealed containers. These units feature temperature alarms, keyed door locks, interior shelving, probe access, and microprocessor temperature control.

Our General Purpose refrigerators provide multi-functional features in a cost-effective design. All units run on natural, hydrocarbon refrigerant for environmental health and energy efficiency.

Certifications



General Description and Application

| | |
|----------------------------------|--|
| Storage capacity (cu. ft) | 14 |
| Door | Solid, right hinged, magnetic door gasket for positive seal |
| Shelves | 5 Adjustable (4 full plus half shelf) |
| Freezer Compartments | Non-applicable |
| Baskets | Non-applicable |
| Mounting | Leveling Legs |
| Interior lighting | Non-applicable |
| Airflow management | Forced draft air circulation |
| External probe access | Rear wall port (3/4" dia.) |
| Insulation | Cabinet is foamed-in-place with EPA compliant high density urethane foam |
| Exterior materials | White powder coated steel |
| Access Control | Keyed door lock |
| General warranty | Two (2) year parts and labor warranty |
| Compressor Parts Warranty | Non-applicable |
| Warranty Disclaimer | Products require 4" of clearance around back and sides of the unit for proper ventilation - improper installation will void the warranty and will lead to temperature maintenance issues, overheating and possible failure |
| Product Weight (lbs) | 180 |
| Shipping Weight (lbs) | 200 |
| Rated Amperage | 2.5 Amps |
| Power Plug/Power Cord | NEMA 5-15 Plug, conforms to UL471 requirements |
| Facility Electrical Requirement | 115V, 60 Hz |
| Agency Listing and Certification | ETL Listed |

Refrigeration System

| | |
|-------------|-------|
| Refrigerant | R600a |
| Defrost | Cycle |

Controller, Configuration, Alarms and Monitoring

| | |
|------------------------------|---|
| Controller technology | Microprocessor temperature controller with digital temperature display, °C/°F switchable |
| Display technology | Standard Digital Temperature Display |
| Adjustable Temperature Range | 1°C to 10°C |
| External alarm connection | State switching remote alarm contacts |
| Alarms | Audible and visual high/low temperature alarms |
| Controller probe | 2 Probes; 1 in air and 1 in sample bottle |
| Disclaimers | These units are NOT designed for use in environments where volatile/explosive conditions could potentially exist Indoor use only, +18°C to +26°C (+65°F to +78°F), <70% RH Specifications are subject to change |

Dimensions

| | Width (in.) | Depth (in.) | Height (in.) | Door Swing (in.) | Total open Depth (in.) |
|----------|-------------|-------------|--------------|------------------|------------------------|
| Exterior | 23 5/8" | 24 3/8" | 73" | 21 7/8" | 46 3/4" |
| Interior | 19" | 16 3/4" | 63 3/4" | | |

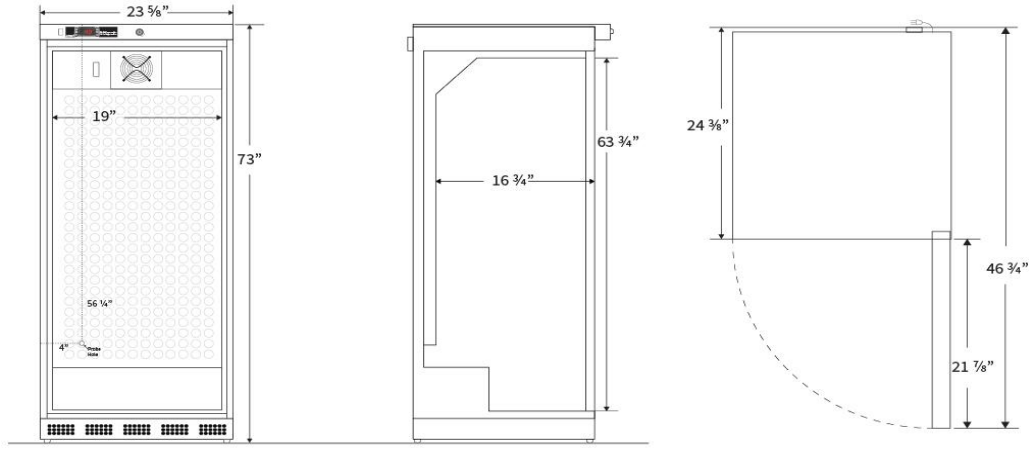

Contact

Customer Service
Technical Service

800-648-4041 Option 3
800-648-4041 Option 5, Parts Option 4

customerservice@horizonscientific.com
technicalservice@horizonscientific.com

Rev_05082023