



Instruction Manual
Rocking Platform Shaker
3-D Rotator Waver



C US

TABLE OF CONTENTS

Package Contents	1
Warranty	1
Installation	2
Maintenance & Servicing	2
Intended Use	2
Environmental Conditions	2
Equipment Disposal	2
Safety Instructions	3-4
Standards & Regulations	3-4
Analog Rocker/Waver Specifications	5
Analog Rocker/Waver Control Panel	6
Analog Rocker/Waver Operating Instructions	6
Digital Rocker Specifications	7
Digital Waver Specifications	8
Digital Rocker/Waver Control Panel	9
Digital Rocker/Waver Operating Instructions	10-11
Troubleshooting	12
Replacement Parts	13-16
Accessories	17

PACKAGE CONTENTS

Rocking Platform Shaker or 3-D Rotator Waver
92" (234cm) detachable power cord
Non-skid rubber mat
Tier kit (analog rocker, 2 tier)
Instruction manual

WARRANTY

Manufacturer warrants this product to be free from defects in material and workmanship when used under normal conditions for five (5) years. Register your equipment or instrument online at: www.vwrsp.com/warranty for US residents or www.vwrcanlab.com/warranty for Canadian residents. For your reference, make a note of the serial number, date of purchase and supplier here.

Serial No.: _____ Date of Purchase: _____

Supplier: _____

INSTALLATION

Upon receiving the VWR Rocker/Waver, check to ensure that no damage has occurred in shipment. It is important that any damage that occurred in transport is detected at the time of unpacking. If you do find such damage the carrier must be notified immediately.

After unpacking, place the Rocker/Waver on a level bench or table, away from explosive vapors. Ensure that the surface on which the unit is placed will withstand typical heat produced by the unit and place the unit a minimum of six (6) inches from vertical surfaces. Always place the unit on a sturdy work surface.

The Rocker/Waver is supplied with a power cord that is inserted into the IEC connector on the back of the unit first, then it can be plugged into a properly grounded outlet. The 120V unit plugs into a 120 volt, 50/60 Hz source. The 230V unit plugs into a 230 volt, 50/60 Hz source.

MAINTENANCE & SERVICING

The Rocker/Waver is built for long, trouble-free, dependable service. No lubrication or other technical user maintenance is required. It needs no user maintenance beyond keeping the surfaces clean. The unit should be given the care normally required for any electrical appliance. Avoid wetting or unnecessary exposure to fumes. Spills should be removed promptly. Do not use a cleaning agent or solvent on the front panel which is abrasive or harmful to plastics, nor one which is flammable. Always ensure the power is disconnected from the unit prior to any cleaning. If the unit ever requires service, contact your VWR representative.

INTENDED USE

The Rocker/Waver is intended for general laboratory use.

ENVIRONMENTAL CONDITIONS

Operating Conditions: Indoor use only.

* For use in CO₂ environments, incubators or cold rooms ranging from -10 to 60°C (14 to 140°F).

Humidity: 80% relative humidity, non-condensing

Altitude: 0 to 6,562 ft (2000 M) above sea level

Mains supply voltage: Fluctuations are not to exceed 10 percent of the nominal supply voltage.

Non-Operating Storage:

* Temperature: -20 to 65°C (-4 to 149°F)

Humidity: maximum 80% relative humidity, non-condensing

Installation Category II and Pollution Degree 2 in accordance with IEC 664.

* **Avoid cold starts:** Unit is not designed to start after being in a cold room environment. Bring unit into cold room from a room temperature environment, operate and remove unit from cold room as soon as operation is complete.

SAFETY INSTRUCTIONS

Please read the entire instruction manual before operating the Rocker/Waver.



WARNING! DO NOT use the Rocker/Waver in a hazardous atmosphere or with hazardous materials for which the unit was not designed. Also, the user should be aware that the protection provided by the equipment may be impaired if used with accessories not provided or recommended by the manufacturer, or used in a manner not specified by the manufacturer.

Always operate unit on a level surface for best performance and maximum safety.

DO NOT lift unit by the platform tray.



CAUTION! To avoid electrical shock, completely cut off power to the unit by disconnecting the power cord from the unit or unplug from the wall outlet. Disconnect unit from the power supply prior to maintenance and servicing.

Spills should be removed promptly. Biohazard spills should be cleaned up using approved laboratory procedures. Solvent spills are a fire hazard. Stop the unit immediately, and **DO NOT** operate until clean up is complete and vapors have dissipated (motor brushes arc and may ignite flammable vapors).

DO NOT immerse the unit for cleaning.

DO NOT operate the unit if it shows signs of electrical or mechanical damage.

The main supply cord provided with this product is rated to safely handle the products electrical load under the stated environmental conditions. **DO NOT** replace this cord with an inadequately rated main supply cord.



Earth Ground - Protective Conductor Terminal

Alternating Current

STANDARDS & REGULATIONS

Troemner, LLC hereby declares under it's sole responsibility that the construction of this product conforms in accordance with the following standards:

Safety standards:

IEC 61010-1 Safety requirements for electrical equipment for measurement, control and laboratory use. Part I: General Requirements.

IEC 61010-2-051 Part II: Particular requirements for laboratory equipment for mixing and stirring.

UL Std. No. 61010-1

CSA/CAN C22.2 No. 0-M91

CSA/CAN C22.2 No. 61010-1-04

EMC standards:

EN61326-1 Class A EN6100-3-3

EN6100-4-5 FCC-B

EN61000-4-4 EN55022-B

EN61000-4-2 EN61000-4-3

EN61000-4-11 EN61000-4-6

Associated EU guidelines:

EMC directive 2004/108/EC

LVD directive 2006/95/EC

ROHS directive 2011/65/EU

CONSIGNES DE SÉCURITÉ

S'il vous plaît lire l'intégralité du manuel d'instructions avant de faire fonctionner l'agitateur orbital.



AVERTISSEMENT! N'UTILISEZ PAS utiliser le secoueur orbital dans un milieu dangereux ou en présence de matières dangereuses non conformes à la conception de l'appareil. L'utilisateur doit également être conscient que la protection assurée par l'équipement peut être amoindrie en cas d'utilisation avec tout accessoire autre que ceux fournis ou recommandés par le fabricant ou en cas d'utilisation contraire aux spécifications du fabricant. Utilisez toujours le dispositif sur une surface à niveau pour optimiser non seulement la performance mais la sécurité.

Toujours utiliser l'appareil sur une surface nivelée pour assurer une performance optimale et un maximum de sécurité.

NE PAS soulever l'appareil en le tenant par le plateau.



MISE EN GARDE! Pour éviter les électrocutions, couper complètement l'alimentation électrique de l'appareil en débranchant le cordon d'alimentation de l'appareil ou de la prise murale. Déconnecter l'appareil de la source d'alimentation électrique avant de procéder à tout entretien ou réparation.

Essuyer immédiatement tout liquide renversé par accident. Déversements de Biohazard doivent être nettoyés à l'aide de procédures de laboratoire approuvés. Déversements de solvants sont un risque d'incendie. Arrêtez immédiatement l'appareil, et ne fonctionnent pas jusqu'à ce que le nettoyage est terminé et vapeurs dissipées (balais pour moteurs arc et peut enflammer les vapeurs inflammables). Ne pas immerger l'appareil pour le nettoyage.

NE PAS immerger l'appareil en vue de son nettoyage.

NE PAS utiliser l'appareil en présence de tout signe de dommage électrique ou mécanique.

Le cordon d'alimentation principal fourni avec ce produit est calibré pour supporter en toute sécurité le chargement des produits électriques dans les conditions définies. NE PAS remplacer ce cordon avec un cordon d'alimentation principal mal classé.



Mise à la terre - Borne du conducteur de protection



Courant alternatif

NORMES ET RÉGLEMENTATIONS

Troemner, LLC déclare par la présente sous sa seule responsabilité que la conception de ce produit répond aux exigences des normes suivantes:

Normes de sécurité:

- IEC 61010-1 Règles de sécurité pour appareils électriques de mesurage, de régulation et de laboratoire. Partie I: Exigences générales.
- IEC 61010-2-051 Partie II: Règles particulières pour les appareils de laboratoire pour le mélange et l'agitation.

UL Std. No. 61010-1

CSA/CAN C22.2 No. 0-M91

CSA/CAN C22.2 No. 61010-1-04

Normes CEM:

- | | |
|--------------|------------------|
| FCC-B | EN55022-B |
| EN6100-3-3 | EN6100-4-5 |
| EN61000-4-2 | EN61000-4-3 |
| EN61000-4-4 | EN61000-4-6 |
| EN61000-4-11 | EN61326-1 Classe |

de l'UE directives:

EMC directive 2004/108/EC

LVD directive 2006/95/EC

ROHS directive 2011/65/EU

ANALOG ROCKER & ANALOG WAVER SPECIFICATIONS



VWR Analog Rocker - Two Tier

Overall dimensions (L x W x H):

Rocker: 17 x 11 x 5" (43.2 x 27.9 x 12.7cm)

Waver: 17 x 11 x 6" (43.2 x 27.9 x 15.2cm)

Platform dimensions (L x W):

14 x 11" (35.5 x 27.9cm)

Electrical (50/60 Hz):

Rocker: 120 volts, 15 watts

230 volts, 15 watts

Waver: 120 volts, 25 watts

230 volts, 25 watts

Fuses:

5mm x 20mm, 5 amp quick acting

Speed range:

1 to 75rpm*

Tilt angle:

Rocker: 0 to 15°*

Waver: 0 to 16°*

Weight capacity:

Rocker: 16lbs (7.3kg)**

Waver: 5lbs (2.3kg)**

Timer:

1 minute to 120 minutes

Controls:

see page 6

Ship weight:

15.5lbs (7kg)

* Maximum speed/tilt angle may vary with heavy or unbalanced loads.

** Centered on tray.

ANALOG ROCKER & ANALOG WAVER CONTROL PANEL

The front panel of the Analog Rocker contains all the controls and displays needed to operate the unit.

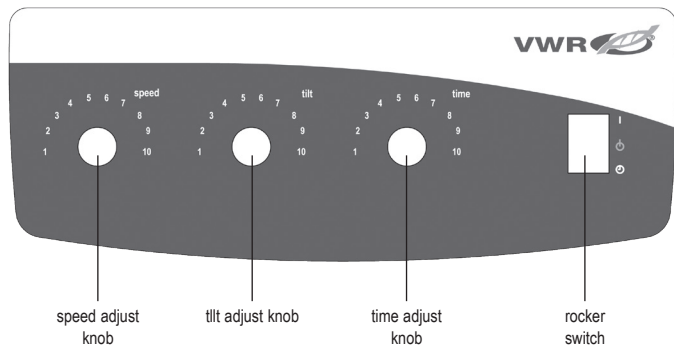

ANALOG ROCKER & ANALOG WAVER OPERATING INSTRUCTIONS

1. Getting ready:

- Rocker switch should be in the center Standby position.
- Plug the power cord into a properly grounded outlet. Manually move the tray to a near horizontal "home" position before powering the unit.
- Position Speed and Tilt knobs between 2 and 3 on the dial.
- Push rocker switch to the "I" On position. The rocker will automatically level and begin running at a moderate speed and tilt.

2. Setting speed and tilt:

- Turn Speed and Tilt knobs to achieve the desired settings.

3. Setting time:

- To run in timed mode, set timer, speed, and tilt knobs to the desired settings.
- Press the rocker switch down to the Time position  and release.
- The unit will now run for the set time.
- To exit the Time mode, press the rocker switch up and return it to the center Standby position.

NOTE: After the timer is set, any time adjustments will not take affect. To reset time, exit Time mode (see step 3D above) and enter new time following the steps above.

OPERATING TIPS:

Centering your sample and even weight distribution on the tray helps balance and stability.

DIGITAL ROCKER SPECIFICATIONS



Overall dimensions (L x W x H):	17 x 11 x 5" (43.2 x 27.9 x 12.7cm)
Platform dimensions (L x W):	12.75 x 10" (32.4 x 25.4cm)
Electrical (50/60 Hz):	120 volts AC, 25 watts 230 volts AC, 25 watts
Fuses:	5mm x 20mm, 5 amp quick acting
Speed range:	1 to 50rpm*
Speed accuracy:	±1rpm
Tilt angle:	0 to 15°*
Weight capacity:	10lbs (4.5kg)**
Timer:	digital, 1 second to 9999 minutes (increased in 1 second increments)
Controls:	see page 4
Ship weight:	15.5lbs (7kg)

* Maximum speed/tilt angle may vary with heavy or unbalanced loads.

** Centered on tray.

VWR Rocker with glassware and plasticware accessories

DIGITAL WAVER SPECIFICATIONS

Overall dimensions (L x W x H):	17 x 11 x 6" (43.2 x 27.9 x 15.2cm)
Platform dimensions (L x W):	11.75 x 8.75" (29.9 x 22.2cm)
Electrical (50/60 Hz):	120 volts AC, 25 watts 230 volts AC, 25 watts
Fuses:	5mm x 20mm, 5 amp quick acting
Speed range:	1 to 30rpm*
Speed accuracy:	±1rpm
Tilt angle:	0 to 20°*
Weight capacity:	5lbs (2.3kg)**
Timer:	digital, 1 second to 9999 minutes (increased in 1 second increments)
Controls:	see page 4
Ship weight:	16lbs (7.3kg)

* Maximum speed/tilt angle may vary with heavy or unbalanced loads.

** Centered on tray.



VWR Waver with plasticware and glassware accessories

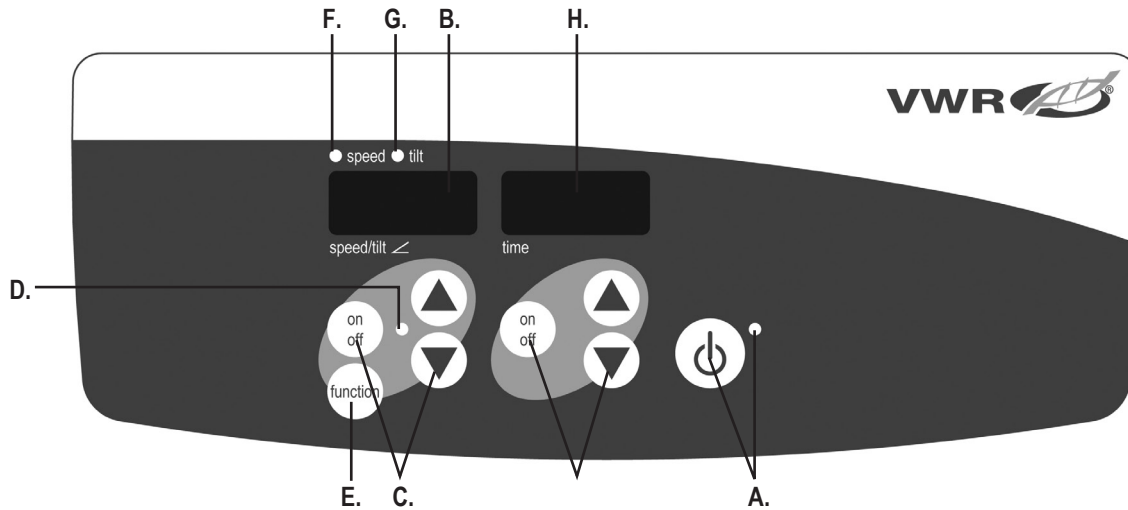

CONTROL PANEL

The front panel of the Rocker/Waver contains all the controls and displays needed to operate the unit.

- A. Standby button/standby indicator light:** The standby indicator light will illuminate when the unit is plugged in. The unit will be in standby mode. Press the standby button to activate the speed/tilt and time functions. The standby indicator light will shut off and the speed/tilt display and time display will illuminate. Press the standby button again and the unit will once again be in standby mode.
- B. Speed/tilt display:** Displays the speed and tilt of the unit. **C.** Up/down arrows for set-point control. **On/off** button starts/stops the rocking/waving function. **D.** The speed/tilt indicator light will be illuminated when the unit is rocking/waving.

- E. Function button:** Press to choose the function you are setting: speed or tilt.
- F. Speed indicator light:** Illuminates when the speed is displayed.
- G. Tilt indicator light:** Illuminates when the tilt angle is displayed.
- H. Time display:** Displays accumulated time (continuous mode) or how much time is remaining (timed mode). **I.** Up/down arrows for set-point control. **On/off** button starts/stops the time function. The display range is from 0 to 9,999 minutes in one (1) second increments. The display will indicate minutes and seconds until the timer reaches 99 minutes and 59 seconds (99:59), then the display will automatically display minutes up to 9,999.

DIGITAL ROCKER/WAVER OPERATING INSTRUCTIONS

The VWR Rocker/Wavers are used for gentle mixing of laboratory samples. These units have been designed for the speed/tilt and time functions to work independently of one another. The speed/tilt can be re-set without re-setting the timer and the timer can be stopped and started without interrupting the rocking/waving functions.

1. Getting ready:

- Plug the power cord into a properly grounded outlet. The standby indicator light will illuminate, verifying power to the unit. Manually move the platform tray to a near horizontal “home” position before powering unit.
- Press the standby button to move the unit from standby mode. The standby indicator light will shut off and the speed/tilt and time displays will illuminate and display the previously used settings.



2. Setting tilt: Electronic tilt enables the user to adjust the angle of tray movement while the unit is rocking/waving or while the unit is stopped.

- Press the function button below the speed/tilt display until the tilt indicator light illuminates. You are now ready to set the tilt angle.
- Press the up/down arrows below the speed/tilt display until you reach the desired angle. When you release the arrow button, the display will blink off and then on indicating the new set angle has been accepted. The unit will complete one rotation at the previously set angle, then smoothly change to the newly programmed angle. The tilt indicator light will flash until the transition to the new tilt angle is complete.

3. Setting speed:

- Press the function button below the speed/tilt display until the speed indicator light illuminates. You are now ready to set the speed.
- Press the up/down arrows below the speed/tilt display until you reach the desired speed. When you release the arrow button, the display will blink off and then on indicating the new set speed has been accepted.

- Press the on/off button to start the rocking/waving function. The indicator light below the speed/tilt display will flash until the transition to the set speed is complete, then the light will stay illuminated indicating the rocking/waving function is in use.
- To stop rocking/waving function, press the on/off button below the speed/tilt display. The unit will complete one full rotation then stop in the horizontal “home” position. The speed indicator light will flash until the rotation is complete. When the cycle is complete, the unit will automatically move to standby mode and the standby indicator light will illuminate.

OPERATING TIPS

When the unit is running at slow speeds or high angles, making large changes to the tilt angle or speed may take several minutes to complete. The quickest way to make large changes to the speed or tilt angle is to stop the unit, change the speed or tilt angle, then restart by pressing the on/off button below the speed/tilt display.

- Setting time to zero (0:00) and continuous mode:** Accumulated time.
 - Press and hold the on/off button below the time display. After three (3) seconds, the display will indicate the previous set time.
 - Simultaneously press both the up and down arrows, the display will indicate zero (0:00). The unit time is now set to zero (0:00) minutes. Alternately, you can use the up/down arrows to get to zero (0:00).
 - Press the on/off button below the time display. The display will indicate the accumulated time. The up/down arrows will become inactive. To stop timer, press the on/off button again. **IMPORTANT:** This will **NOT** interrupt the rocking/waving function. Press the on/off button below the speed/tilt display to interrupt the rocking/waving function.
 - To re-set, press and hold the on/off button below the time display. After three (3) seconds, the display will indicate the previous set time, which was zero (0:00).

DIGITAL ROCKER/WAVER OPERATING INSTRUCTIONS

5. **Setting timed mode:** Programmed time.
 - a. Press the up/down arrows below the time display until you reach the desired time.
 - b. Start this function by pressing the on/off button below the time display. The unit will run for the selected time, the up/down arrows will become inactive while the timer is running. The unit will stop rocking/waving when time display reaches zero (0:00). Four (4) audible beeps will indicate the time down function is complete. The time display will default back to the set time. To repeat for the same time, simply depress the on/off button again.
 - c. To interrupt an automatic timing cycle before it is completed, press the on/off button below the time display. The time display will flash off and on to indicate the time function is on "hold". **IMPORTANT:** This will **NOT** interrupt the rocking/waving function. Press the on/off button below the speed/tilt display to interrupt the rocking/waving function. Restart the timer by pressing the on/off button below the time display. Unit will continue counting down to zero (0:00). When the display reaches zero (0:00), you will hear the four (4) audible beeps that indicate the time down function is complete and the rocking/waving function will cease.

6. **Turning unit off:**
 - a. To turn the unit off, press the standby button. The speed/tilt and time displays will be blank, the standby indicator light will illuminate. The Rocker/Waver should be kept in standby mode when not in use. To completely cut off power to the unit, disconnect the power cord from the unit or un-plug from the wall outlet.

OPERATING TIPS

Built-in memory maintains the last used speed/tilt and time settings during a power interruption. A built-in program will shut power off to the motor if the platform tray is prevented from rocking/waving, or the unit is overloaded beyond it's recommended weight capacity.

TROUBLESHOOTING ANALOG ROCKER/WAVER

If the tray motion is obstructed or the unit is mechanically overloaded, the unit will beep and attempt to restore controlled rocking motion. If unit can not recover on its own, disconnect power cord, reduce load, speed or tilt setting and repeat run.

TROUBLESHOOTING DIGITAL ROCKER/WAVER

Problem	Cause	Solution
E03	Mechanical obstruction Ceased motor Drive belt broken	<p>The E03 error can be addressed by the user. Press the standby button to clear this error. If the E03 error persists, along with grinding, knocking or rubbing noises, un-plug the unit and contact your VWR representative for repairs.</p> <p>In the event of an errant E03 error, such as someone inadvertently touching the platform tray while the unit is running, the unit will automatically go to the horizontal "home" position and restart. In the event of an obstruction left under the tray, which would cause the unit to continually restart, the unit will attempt to auto home and restart four (4) times and then stop running, displaying an E03 error. This error can be cleared by the user by pressing the standby button.</p>
E04	Maximum load exceeded	<p>The E04 error can be addressed by the user. Press the standby button to clear this error. Be sure the load is within the maximum load specification before restarting the unit. If the E04 code persists, un-plug the unit and contact your VWR representative for repairs.</p>

ANALOG ROCKER REPLACEMENT PARTS

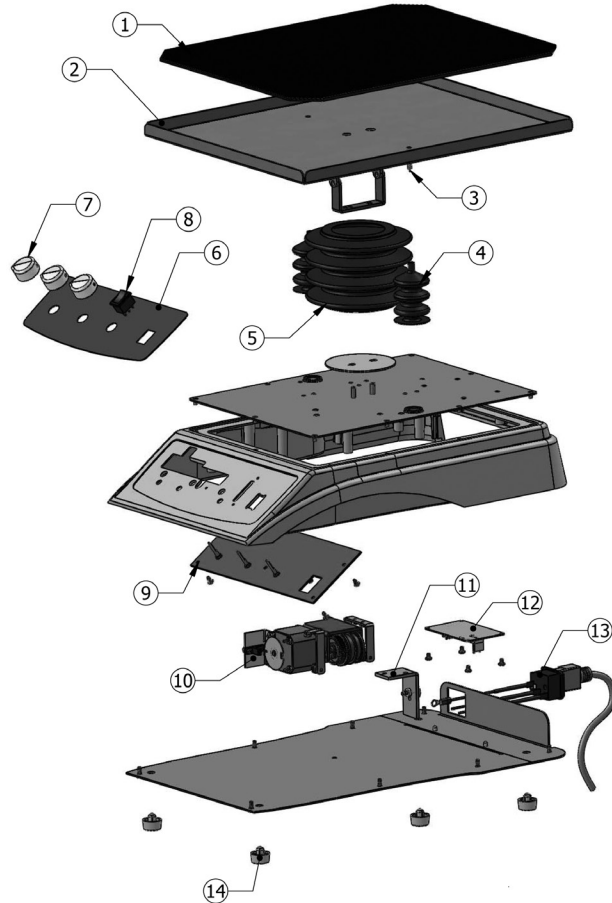

DESCRIPTION	PART NUMBER
1. Non-skid rubber mat	580085-00
2. Tray assembly	880546-00
3. Spring	180175-00
4. Bellows rocker	280436-00
5. Bellows center	280434-00
6. Front panel	380914-00
7. Knob	287010-00
8. Switch assembly	380912-00
9. PCBA	380913-00
10. Motor assembly	880547-00
11. Idler assembly	880548-00
12. Power supply	380910-00
13. IEC wire assembly:	
120V:	380790-00
230V:	380237-00
Fuse:	380238-00
14. Feet	149023-00
Detachable 92" (234cm) power cord:	
120V:	330100-00
Euro plug:	330101-00
UK plug:	330102-00
Swiss plug:	330103-00

ANALOG WAVER REPLACEMENT PARTS

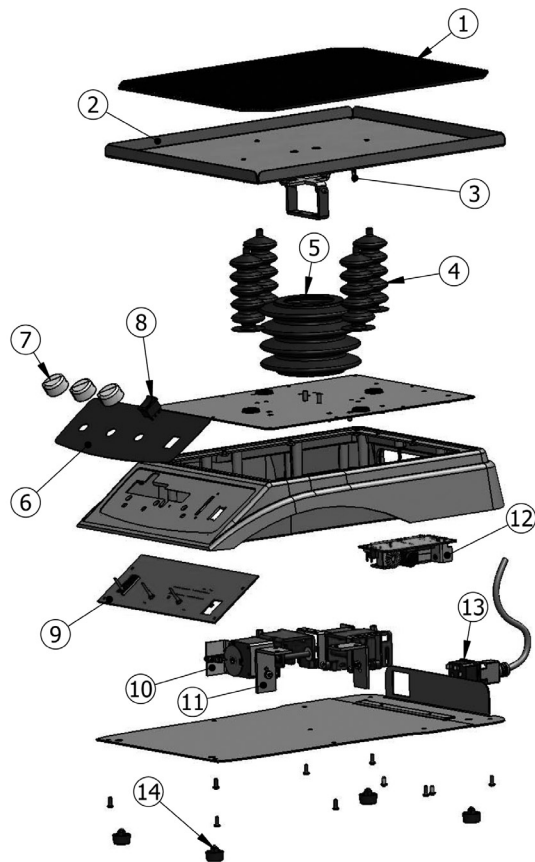

DESCRIPTION	PART NUMBER
1. Non-skid rubber mat	580085-00
2. Tray assembly	880546-00
3. Spring	180062-00
4. Bellows waver	280435-00
5. Bellows center	280434-00
6. Front panel	380923-00
7. Knob	287010-00
8. Switch assembly	380912-00
9. PCBA	380913-00
10. Motor assembly	880547-00
11. Idler assembly	880548-00
12. Power supply	386687-00
13. IEC wire assembly:	
120V:	380776-00
230V:	380237-00
Fuse:	380238-00
14. Feet	149023-00
Detachable 92" (234cm) power cord:	
120V:	330100-00
Euro plug:	330101-00
UK plug:	330102-00
Swiss plug:	330103-00

DIGITAL ROCKER REPLACEMENT PARTS

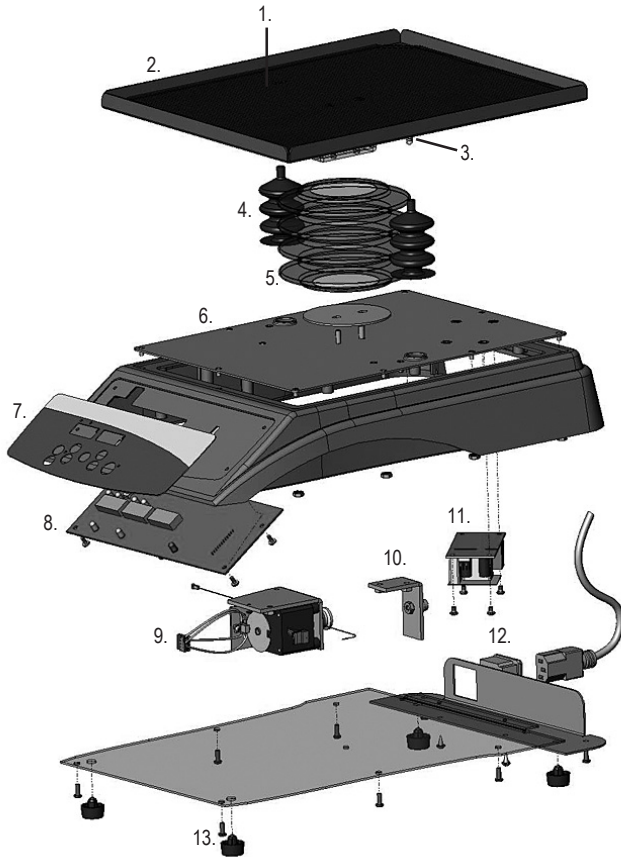

DESCRIPTION	PART NUMBER	
1. Non-skid rubber mat		580076-00
2. Tray assembly		880523-00
3. Spring		180062-00
4. Bellows rocker		280436-00
5. Bellows center		280434-00
6. Platform tray		280405-00
7. Front panel		380724-00
8. Circuit board		380735-00
9. Motor assembly		880533-00
10. Idler assembly		880531-00
11. Power supply		386453-00
12. Power entry module	120V	380755-00
	230V	380237-00
Fuse		380238-00
13. Feet		149023-00
Detachable 92" (234cm) power cord,	120V	330100-00
	Euro	330101-00
	UK	330102-00
	Swiss	330103-00

DIGITAL WAVER REPLACEMENT PARTS

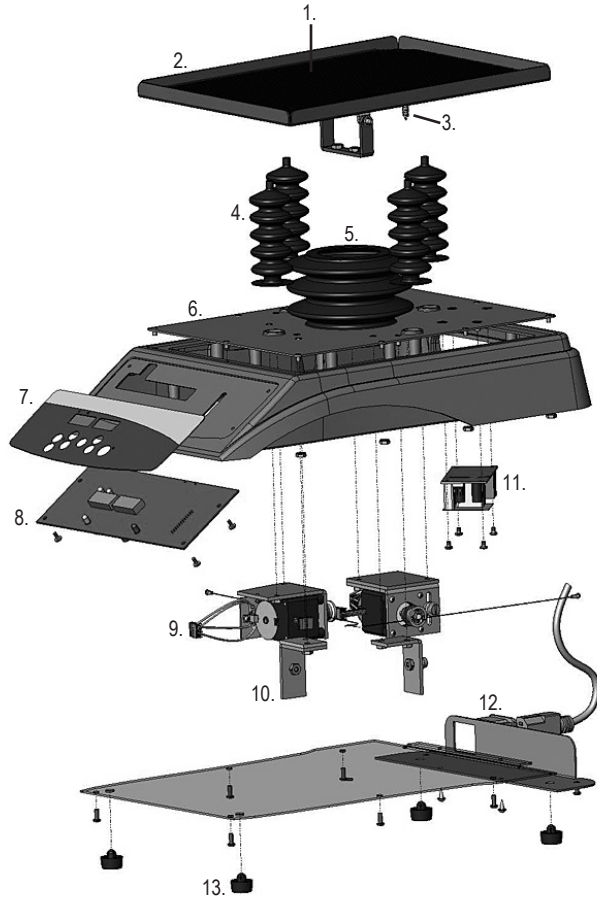

DESCRIPTION	PART NUMBER	
1. Non-skid rubber mat		580077-00
2. Tray assembly		880522-00
3. Spring		180062-00
4. Bellows waver		280435-00
5. Bellows center		280434-00
6. Platform tray		280982-00
7. Front panel		380726-00
8. Circuit board		380735-00
9. Motor assembly		880532-00
10. Idler assembly		880531-00
11. Power supply		386453-00
12. Power entry module	120V	380755-00
	230V	380237-00
Fuse		380238-00
13. Feet		149023-00
Detachable 92" (234cm) power cord,	120V	330100-00
	Euro	330101-00
	UK	330102-00
	Swiss	330103-00

ACCESSORIES

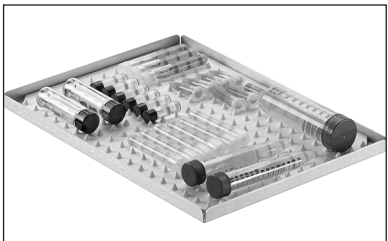

DIMPLED MAT

Designed to hold centrifuge tubes, vials, culture tubes, and micro-tubes securely in place. Mat can be easily removed for cleaning and transporting tubes from bench to tray.

<u>DESCRIPTION</u>	<u>PART NUMBER</u>
Dimpled mat, 14L x 11"W (35.5 x 27.9cm), Rocker (analog)	10127-728
Dimpled mat, 12.75L x 10W" (32.4 x 25.4cm), Rocker (digital)	12985-030
Dimpled mat, 11.75L x 8.75W" (29.9 x 22.2cm), Waver (digital)	12985-034

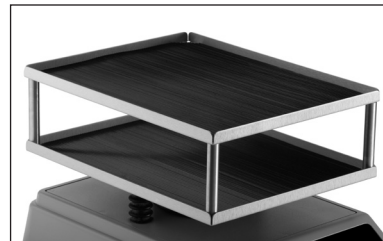

STACKING TRAY

Easily attaches to the lower platform tray to add a second tier for higher capacity applications. Second tier tray mounts 3.5" (8.9cm) above the lower tray.

<u>DESCRIPTION</u>	<u>PART NUMBER</u>
Stacking tray, Rocker (analog)	10127-726
Stacking tray, Rocker (digital)	12620-914
Stacking tray, Waver (digital)	12620-924

MANUFACTURED BY:

TROEMNER LLC

201 Wolf Drive • PO Box 87 • Thorofare, NJ 08086-0087
Phone: 856-686-1600 • Fax: 856-686-1601 • E-mail: troemner@troemner.com
www.troemner.com

715062-00 (REV 12 - 8/16)