

Description	25 ml 3-Well Disposable Reagent Reservoirs		
Biotix Part #	SR-0025-53SWM	SR-0025-13SWM	SR-0025-B3WM
Maximum Volume	25 ml	25 ml	25 ml
Graduation Marks	Yes		
Certified Pre-Sterile	Yes	Yes	No
Material	Polystyrene		
Divided Wells	3-wells		
Features	Angled sides V-shaped bottom		
Packaging	5 reservoirs/bag, 10 bags/pack	1 reservoir/bag, 25 bags/pack	Bulk, 100 reservoirs/pack

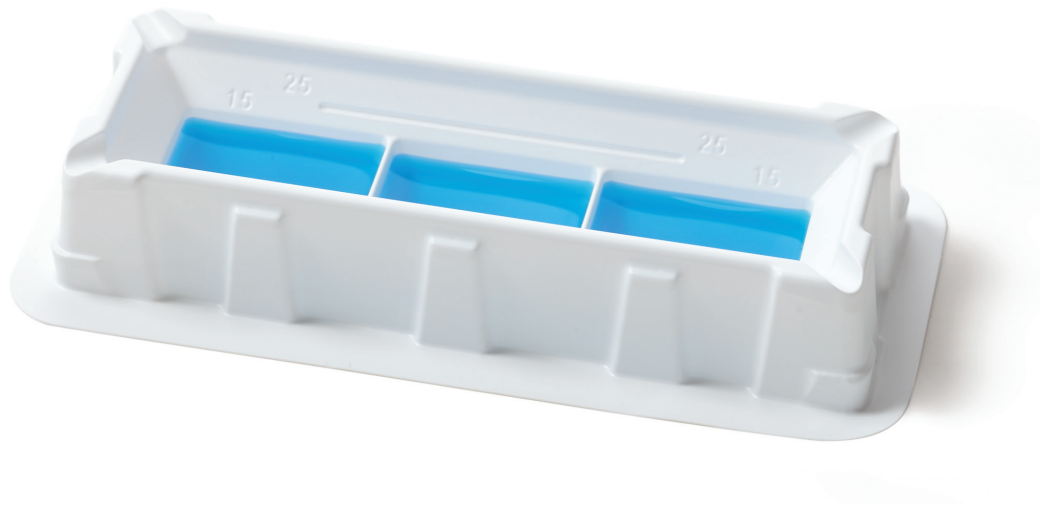

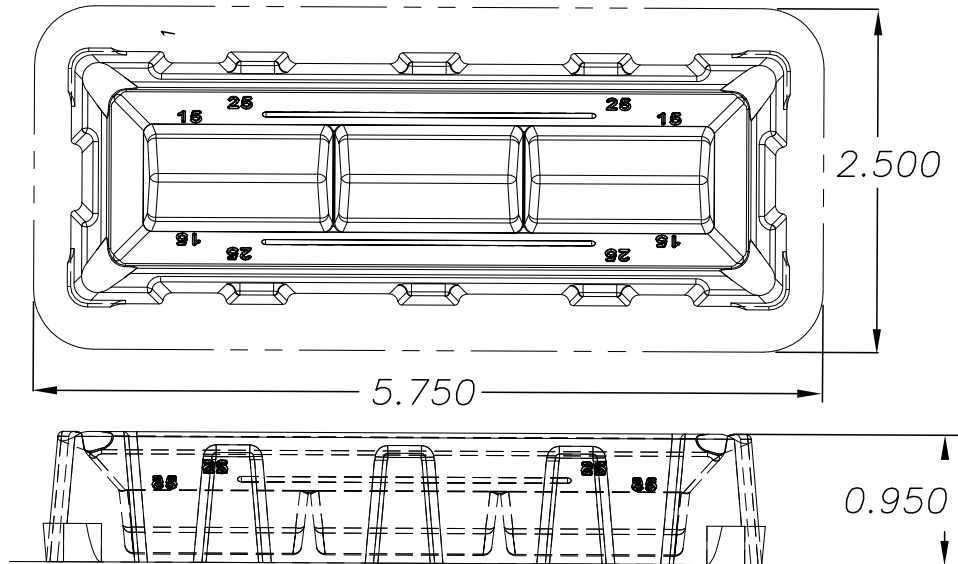

## Product Dimensions



## Quality Testing

<b>RNase/DNase</b>	Products are washed in distilled water and concentrated via centrifugation. Samples are added to previously established nucleic acid standards, incubated for one hour at 37°C, and tested on a 2% gel using electrophoresis. Products must show no degradation of standards to pass. Test sensitivity is 10 <sup>-7</sup> Kunitz units/μl.
<b>Nucleic Acid</b>	Products are washed in distilled water and concentrated via centrifugation. Then, samples are added to protocol specified PCR reactions and thermal cycled for 50 cycles. A 2% agarose gel electrophoresis is used to examine experimental samples, positive controls, and negative controls. To pass, product samples must show no DNA amplification. Test sensitivity is 10 ng.
<b>Endotoxin/Pyrogen</b>	Products are tested for endotoxins by using the Limulus Amebocyte Lysate (LAL) gel assay according to FDA guidelines. Test sensitivity is 0.06 EU/ml.
<b>Trace Metal</b>	Products are washed in distilled water. The sample is then tested using reflectometry using a single strip test for the following metals: Ca, Cu, Fe, K, Mg, Mn and Ni. Standard solutions are used as positive controls. A reader is used to detect metals to a sensitivity of 500 mg/L.
<b>PCR Inhibitor</b>	Products are tested via PCR amplification and gel electrophoresis analysis. Samples must show normal amplification to be considered free of PCR inhibitors.
<b>Sterilization</b>	Products are sterilized using electron beam irradiation.

©2013, Biotix, Inc. All rights reserved

Biotix, Fluid Innovation, Delta Filter, X-Resin, Blade, FlexFit, Statix, Leave Nothing Behind, BioReady, Tip Eject, and XTreme Quality are registered trademarks or trademarks of Biotix, Inc. All other brands and names contained herein are the property of their respective owners.