

89260-050

4' PROTECTOR PREMIER LABORATORY HOOD

NOMINAL WIDTH	TOTAL EXHAUST CFM & STATIC PRESSURE	100 FPM S.P.	80 FPM S.P.	60 FPM S.P.
4 FEET	⊕ 18" SASH OPENING (62.5% OPEN)	450 0.09"	365 0.06"	270 0.03"
4 FEET	⊕ 28" SASH OPENING (100% OPEN)	725 0.22"	580 0.14"	435 0.08"

NOTE: SASH STOP INCLUDED AT 18" POSITION.

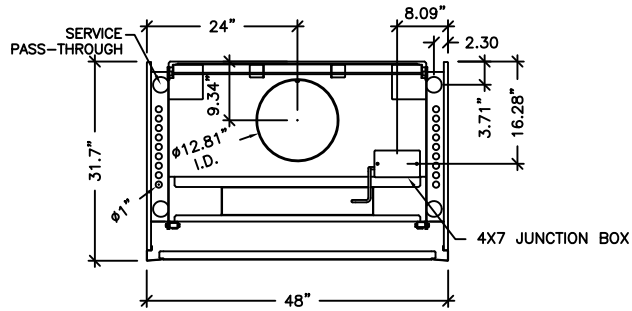

TOP VIEW
SCALE: 1/2" = 1'-0"

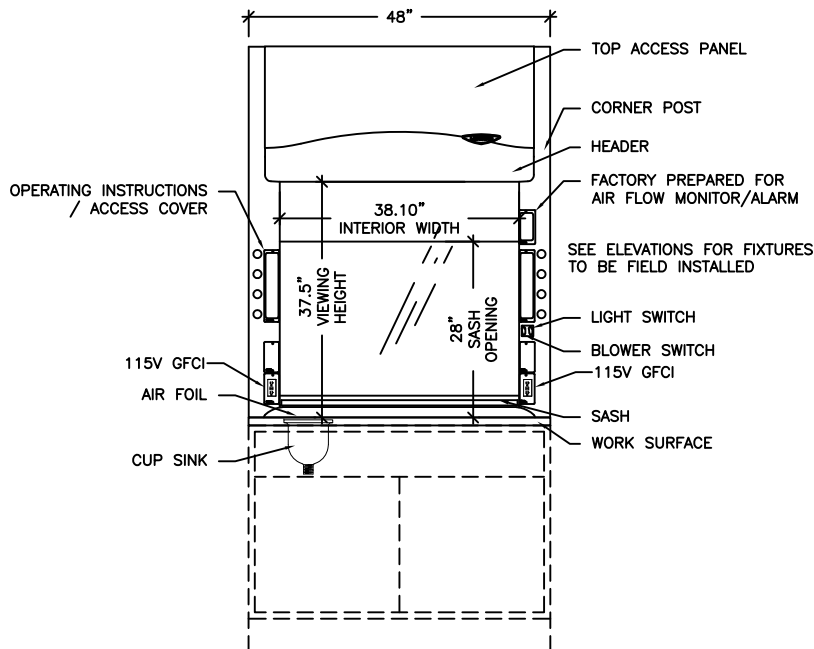

FRONT VIEW
SCALE: 1/2" = 1'-0"

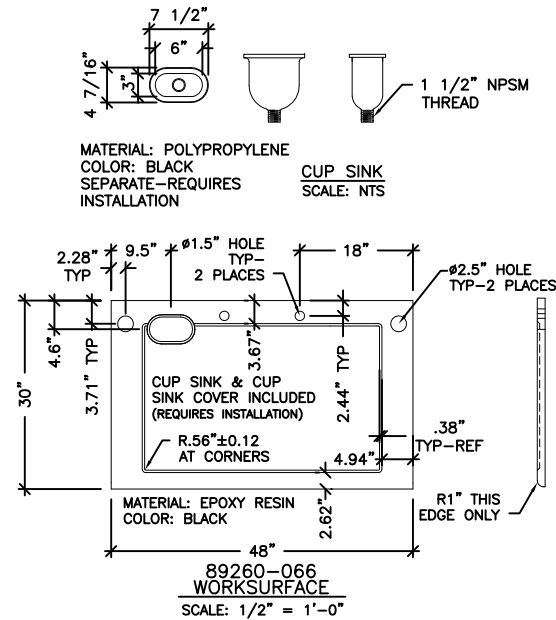

89260-066
WORKSURFACE
SCALE: 1/2" = 1'-0"

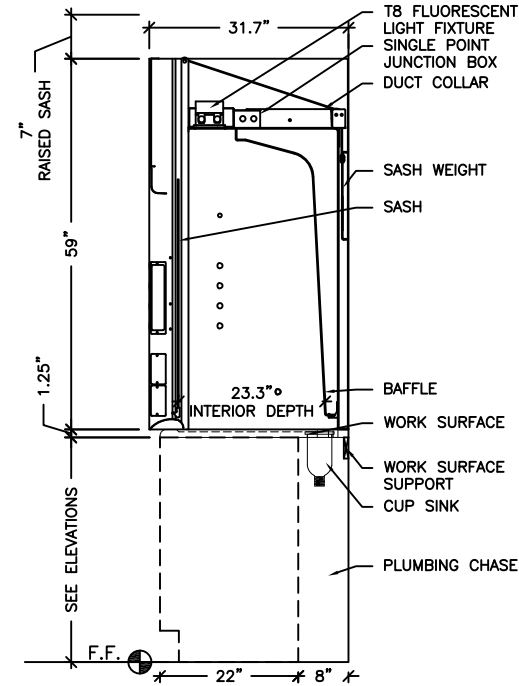

SIDE VIEW
SCALE: 1/2" = 1'-0"

GENERAL DESCRIPTIONS

EXTERIOR SUPERSTRUCTURE

DOUBLE WALL CONSTRUCTION
18 GAUGE COLD ROLLED STEEL
COLOR: GLACIER WHITE

INTERIOR SUPERSTRUCTURE

GALVANIZED STEEL (STANDARD)

LEFT / RIGHT FACIA

POWDER COATED STEEL
COLOR: GLACIER WHITE

LINER MATERIAL

MOLDED FIBERGLASS REINFORCED POLYESTER RESIN

SIDE PANELS

BOTH SIDES - REMOVABLE
COLOR: GLACIER WHITE

ELECTRICAL FIXTURES

FLUORESCENT LIGHT AND TUBES W/ SWITCH
(2) 115V / 60HZ / 20A GFCI DUPLEXES
ADDITIONAL ELECTRICAL FIXTURES ORDERED SEPARATELY
TO BE INSTALLED AND WIRED BY OTHER

WIRING

FUME HOOD WIRED AT FACTORY
ELECTRICAL CONNECTION MADE INSIDE 4X7 JUNCTION BOX
100-115V, 50/60 HZ
OVERLOAD RELAY THERMAL UNIT (P-HEATER) NOT
PROVIDED WITH HOOD

SASH

VERTICAL TRAVEL
TEMPERED SAFETY GLASS
COUNTER WEIGHTED AND BALANCED
PULLEY SYSTEM
SASH STOP ⌀ 18"

BAFFLES

MOLDED FIBERGLASS REINFORCED POLYESTER RESIN

INTERIOR ACCESS PANELS

NONE

CORNER POST WITH ACCESS COVERS

RIGHT AND LEFT SIDES
18 GAUGE COLD ROLLED STEEL

AIR FOIL

COLD ROLLED STEEL
POWDER COAT FINISH

EXHAUST CONNECTION

MOLDED FIBERGLASS 12.81" ID

WORKSURFACE

ORDERED SEPARATELY

CUPSINK

INCLUDED WITH WORKSURFACE

CABINETS

ORDERED SEPARATELY - SEE ELEVATION(S)

REMOTE BLOWER

ORDERED SEPARATELY

ALARM / MONITOR

ORDERED SEPARATELY AS REQUIRED

PLUMBING

SERVICE FIXTURE KITS ORDERED SEPARATELY AS REQUIRED
TO BE INSTALLED AND PLUMBED BY OTHER