

Exterior



Front View

Side View

Top View

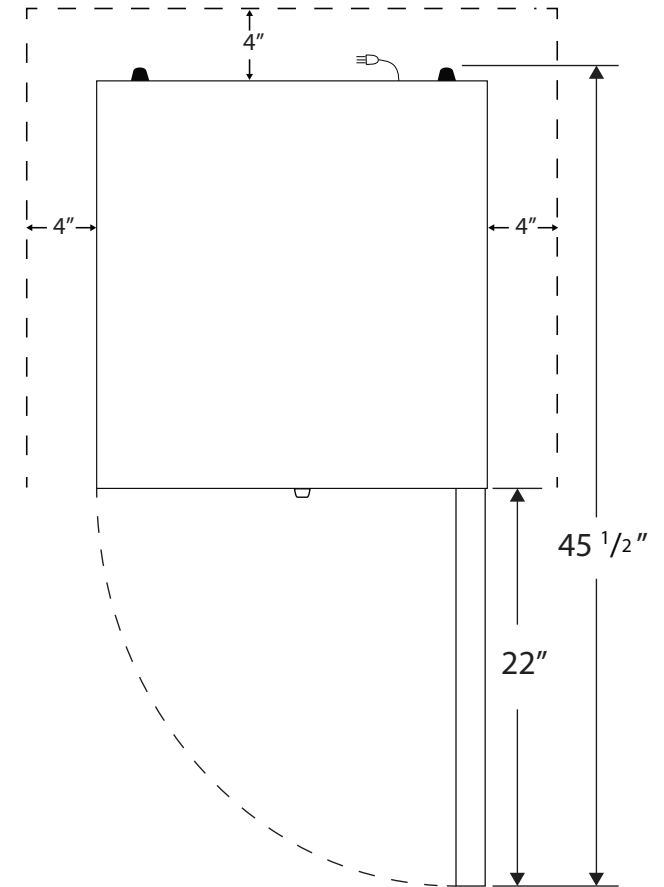
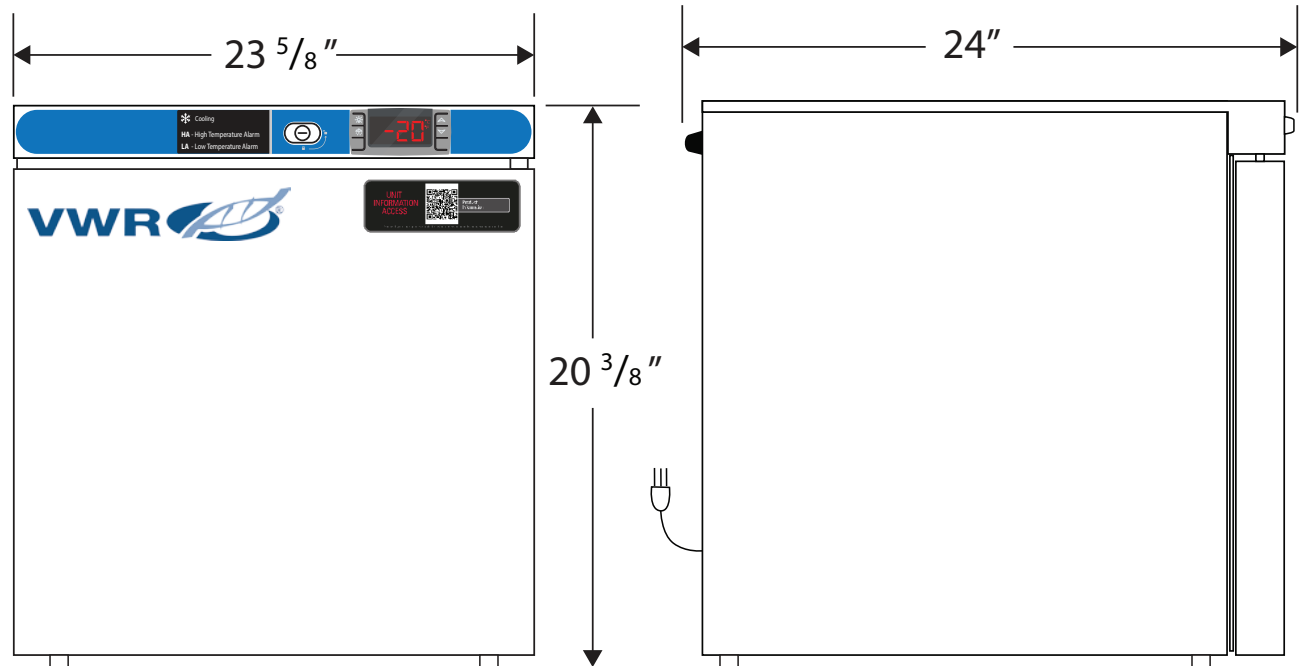

NOTE: Ventilation Requirements – Minimum 4" clearance on sides and back

Cat# 10819-662/HCUCFS0120

115VAC/60Hz/1PH
 NEMA-5-15P

Cu.Ft.	Defrost	Door	Int Door	Shelves	W"	D"	H"	Refrigerant	H.P.	Amps	Weight
1.7	Manual	1 Solid	0	2 Adj +Footed Bottom	23 5/8	24	20 3/8	R600a	1/8	1	80 lbs.