

STERILMATIC STERILIZER AUTOCLAVE

- STM-E** - Domestic Fixed Temperature
- STM-EL** - Domestic Adjustable Temperature
- STM-EX** - Export Fixed Temperature
- STM-ELX** - Export Laboratory Adjustable Temperature



STM-E shown

OPERATION SHALL BE BY:

Sterilizing cycle will be fully automatic, time-controlled and have a built-in temperature control which provides 250°F (121°C). Model STM-EL has the additional feature of an adjustable temperature control that can be set anywhere from 230°-250°F (110°- 121°C) range. All operating controls will be located at the top, front of the Sterilizer. Pressure will be automatically and quickly exhausted and power supply shut off at termination of cycle. Slow exhaust may be selected for sterilizing liquids.

Standard Features

- Automatic temperature control
- Thermometer 180°-300°F (82°-149°C)
- Safety valve
- 0-30 lb. steam gauge
- 0-60 minute timer
- Low water cut-off
- Thermostatic steam trap
- Signal light
- Flat perforated steam baffle
- Removable pan supports
- Adjustable 4" to 6" bullet feet
- Manual fill

Shipping Weight

- All Models - 150 lbs (68 kg)

OPTIONS & ACCESSORIES AT ADDITIONAL COST

- | | | |
|--|--|---|
| <input type="checkbox"/> Sterilmatic trays (stainless steel, one piece, round cornered) Perforated trays available in the following sizes: | <input type="checkbox"/> Sterilmatic wire basket (recommended for dressings) | <input type="checkbox"/> Sterilmatic tubular leg stainless steel stand with shelf |
| <input type="checkbox"/> 12" x 20" x 2-1/2" (holds 3 of this size) | Available in the following sizes: | <input type="checkbox"/> Second shelf for tubular leg stainless steel stand |
| <input type="checkbox"/> 12" x 20" x 4" (holds 2 of this size + one 2-1/2" tray) | <input type="checkbox"/> 12" x 20" x 2-1/2" | <input type="checkbox"/> Exhaust condenser (for condensing exhaust steam when unit cannot be vented to outside) |
| <input type="checkbox"/> 12" x 20" x 6" (holds one of this size + one 2-1/2" tray) | <input type="checkbox"/> 12" x 20" x 4" | |

STANDARD CONSTRUCTION SPECIFICATIONS

Will be a Market Forge Electric model STM-E, STM-EL, STM-EX or STM-ELX Automatic Steam Pressure Sterilmatic Sterilizer (Autoclave). The Sterilmatic is dependable, and ideally suited for laboratories, veterinary clinics, processing plants and more.

CYLINDER

Sterilizing cylinder will be A.S.M.E. constructed and National Board Registered 3/16" (4.8mm) thick welded aluminum.

Sterilizer exterior is made of polished stainless steel. Interior dimensions of 16" (406mm) in diameter and 26" (660mm) long with a cubic content of 5,220 cubic inches (85 liters) and will have a door opening of 13-1/2" (343mm) wide and 11" (279mm) high.

Sterilizing compartment will have a pan capacity of:

- (3) 12" x 20" x 2-1/2" (305mm x 508mm x 64mm) or
- (2) 12" x 20" x 4" (305mm x 508mm x 102mm) or
- (1) 12" x 20" x 6" (305mm x 508mm x 152mm)

DOOR

The sterilizer door will be self-sealing type which cannot be opened until steam pressure is completely exhausted.

Door will be 12 gauge stainless steel, removable for cleaning without tools.

Door gasket will be one-piece molded, replaceable without tools or cement.



Approval Notes: _____

DIMENSIONS ARE IN INCHES [MM]

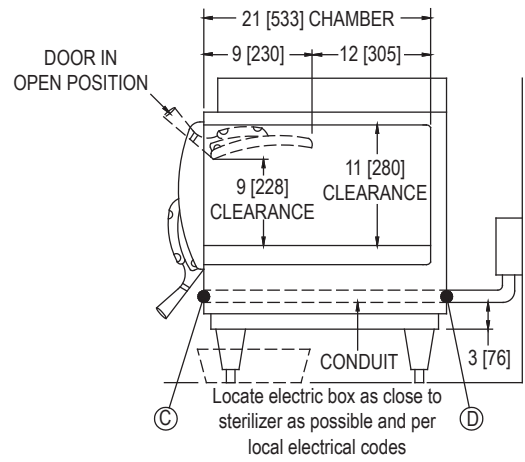
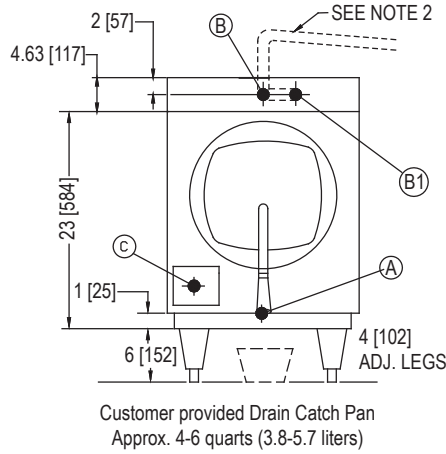
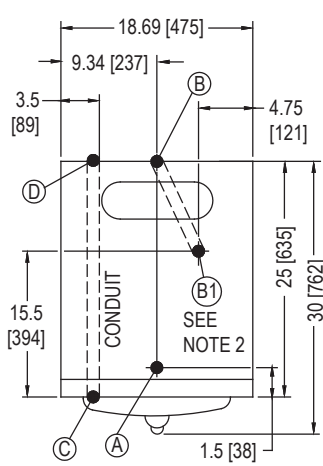

SERVICE CONNECTIONS

| SYMBOL | DESCRIPTION | NOTES |
|--------|--|--|
| A | Drain - 1/2" (13mm) N.P.T. of 3/8" (10mm) OD copper (see note 1) | 1. An air break must be provided if a unit drain line is run. 2. Vent exhaust to atmosphere. B1 is actual connection, but must exit casing at B. 3. Heat of Rejection (Heat Loss Into the Room) 6,000 BTU'S. |
| B | Steam Exhaust Connection - 5/8" (16mm) (see note 2) | |
| C | Electrical Connection - (*see electrical specifications) | |
| D | Power Supply | |

The manufacturer reserves the right to modify materials and specifications without notice.

ELECTRICAL CHARACTERISTICS AND SPECIFICATIONS

| Model | kW | Hz | 1 Phase | | | 3 Phase | | | |
|---------|------|----|---------|------|------|---------|------|----------|----------|
| | | | 208V | 220V | 240V | 208V | 240V | 220/380V | 240/415V |
| STM-E | 9.3 | 60 | 45A | - | - | 26A | - | - | - |
| STM-EL | 12.4 | 60 | - | - | 52A | - | 30A | - | - |
| STM-EX | 10.4 | 50 | - | 48A | - | - | - | 16A | - |
| STM-ELX | 12.4 | 50 | - | - | 52A | - | - | - | 18A |

Unit must be grounded. Main supply voltage fluctuations are not to exceed ± 10% nominal supply voltage.

Clearance from combustible and non-combustible construction should be a minimum of 4" in the back and 2" on the sides.

WATER SUPPLY AND DRAIN SPECIFICATIONS

Good quality water feed is the responsibility of the owner. Water quality must be within the following general guidelines.

TDS: 40-125 ppm Hardness: 35-100 ppm pH: 7.0 - 8.5 Silica: <13 ppm Chlorides: <25 ppm Chlorine: <0.2 ppm Chloramine: <0.2 ppm

The best defense against poor water quality is a water treatment system designed to meet your water quality conditions.

Appliance to be installed with backflow protection according to federal, state or local codes.

IMPORTANT: Exhaust line must be vented to the outside to eliminate the exhaust steam and the accompanying noise from entering the room. Use 1/2" (13mm) copper tubing or suitable alternate. The overall height and length of the line should not rise more than 4' (1.2 meters) above the unit and exceed 15' (4.5 meters) with a minimum of bends. The line should slope downward after leaving the sterilizer in order to ensure condensate drainage.

IMPORTANT: Failure to comply with this outline will affect the sterilization process.

When an exhaust condenser is supplied; the following services must be provided: 1/2" (13mm) cold water: 1" (25mm) waste: 115V electrical line.

**INTENDED FOR COMMERCIAL USE ONLY.
NOT FOR HOUSEHOLD USE.**

