



76580-188

## VWR-HC-RFP-17

### Product Data Sheet

17 Cu. Ft VWR® Standard Series Solid Door Laboratory Refrigerator

#### Images



#### Product Description

Laboratory refrigerators offer professional cold storage for scientific and industrial settings. Units come equipped with temperature alarms, keyed door locks, forced draft circulation, probe access, and precise temperature monitoring through microprocessor control.

Our VWR® Standard Series refrigerators provide multi-functional features in a cost-effective design. All units run on natural, hydrocarbon refrigerant for environmental health and energy efficiency.

#### Certifications



#### General Description and Application

Storage capacity (cu. ft)	17
Door	Right Hinged
Shelves	5 adjustable shelves
Freezer Compartments	Non-applicable
Baskets	Non-applicable
Mounting	Leveling Legs
Interior lighting	Non-applicable
Airflow management	Forced draft air circulation
External probe access	Rear wall port (3/4" dia.)
Insulation	Cabinet is foamed-in-place with EPA compliant high density urethane foam
Exterior materials	White powder coated steel
Access Control	Keyed door lock
General warranty	Two (2) year parts and labor warranty
Warranty Disclaimer	Products require 4" of clearance around back and sides of the unit for proper ventilation - improper installation will void the warranty and will lead to temperature maintenance issues, overheating and possible failure
Product Weight (lbs)	225
Shipping Weight (lbs)	250
Rated Amperage	2.5 Amps
Power Plug/Power Cord	NEMA 5-15 Plug, conforms to UL471 requirements
Facility Electrical Requirement	115V, 60 Hz
Agency Listing and Certification	ETL, C-ETL listed and certified to UL471 standard, hydrocarbon refrigerant safety

#### Refrigeration System

Refrigerant	R600a
Defrost	Cycle

#### Controller, Configuration, Alarms and Monitoring

Controller technology	Microprocessor temperature controller with digital temperature display, °C/°F switchable
Display technology	Standard Digital Temperature Display
Adjustable Temperature Range	1°C to 10°C
External alarm connection	State switching remote alarm contacts
Alarms	Audible and visual high/low temperature alarms
Controller probe	2 Probes; 1 in air and 1 in sample bottle
Digital Communication	Non-applicable
Data Transfer	Non-applicable
Disclaimers	Indoor use only, +18°C to +26°C (+65°F to +78°F), <70% RH
	Specifications are subject to change

**Dimensions**

	Width (in.)	Depth (in.)	Height (in.)	Door Swing (in.)	Total open Depth (in.)
Exterior	30 3/4"	28 5/8"	67 3/4"	28 3/4"	57 3/8"
Interior	26 1/4"	20 7/8"	58 1/2"		

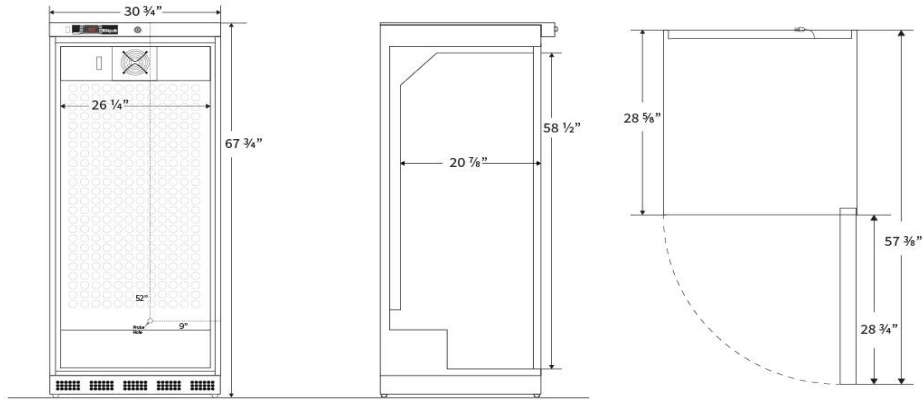

**Contact**

Warranty Service 1-800-268-4355  
 Technical Service 1-888-897-5463

[warranty@vwr.com](mailto:warranty@vwr.com)  
[technicalproductsupportna@vwr.com](mailto:technicalproductsupportna@vwr.com)

Rev\_07102023