



Profit from the Eagle Advantage®

Specification Sheet

Short Form Specifications

Solid or perforated. 14 gauge worksurface. Perforations are 3/4" on 1" centers. #4 brushed finish or electropolished. 1 1/2" tubular base with C- or H-frame. Uni-lok® gusset system. Stainless bullet feet adjustable to 1".

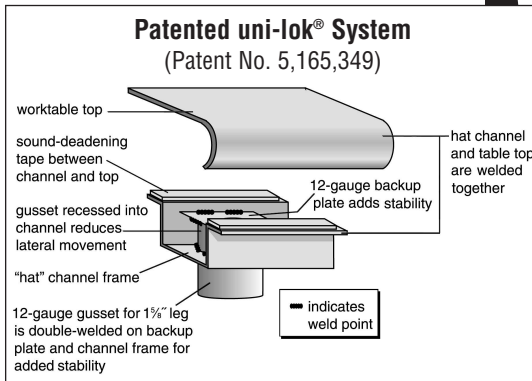
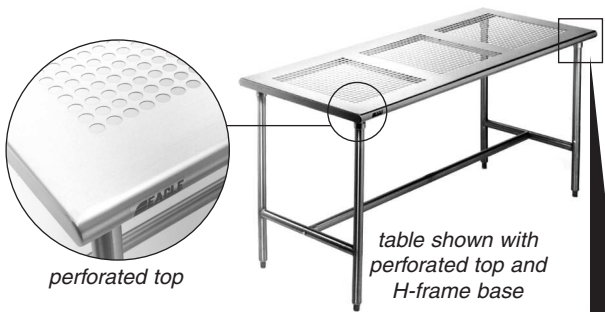
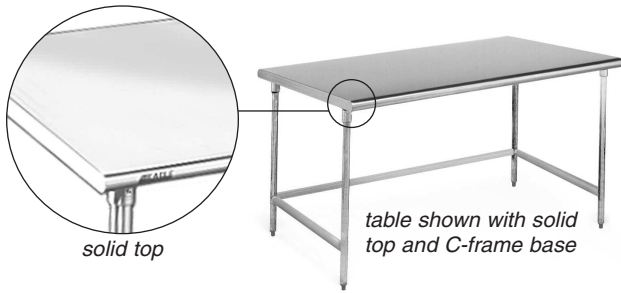

Item No.: _____
 Project No.: _____
 S.I.S. No.: _____

Cleanroom Tables with Solid or Perforated Tabletop

MODELS:

- | | | |
|-----------------------------------|-----------------------------------|-----------------------------------|
| <input type="checkbox"/> SEP24* | <input type="checkbox"/> SEP30* | <input type="checkbox"/> SEP36* |
| <input type="checkbox"/> CRT24* | <input type="checkbox"/> CRT30* | <input type="checkbox"/> CRT36* |
| <input type="checkbox"/> EPCRT24* | <input type="checkbox"/> EPCRT30* | <input type="checkbox"/> EPCRT36* |
| <input type="checkbox"/> CRPT24* | <input type="checkbox"/> CRPT30* | <input type="checkbox"/> CRPT36* |

* See chart on back for complete model numbers.

Design and Construction Features

- Heavy gauge type 304 all stainless steel construction.
- Tops are 14 gauge, electropolished or brushed stainless steel and reinforced with heavy gauge hat channels. Alcohol-wiped and cleanroom bagged.
- 1 1/2" (38mm)-diameter, rolled down edges at front and rear.
- Ends turned down 90° at 1 1/2" (38mm) providing for flush installations when required.
- Base assembly incorporates the "strength by design" patented uni-lok® (patent #5,165,349) stainless steel gusset system which is welded into hat channel, reducing lateral movement.
- Legs and crossbracing are 16 gauge 1 1/2" (41mm)-diameter with welded crossbracing front to back and choice of center or rear knocked-down crossbracing.
- For solid top tables, undershelves are heavy gauge construction with hat channel reinforcement on tables 84" (2134mm) and longer.
- For perforated tables, perforations are 3/4" (19mm) diameter on 1" (25mm) centers to allow a minimum 40% laminar flow.
- Tables supplied with 1" (25mm) adjustable stainless steel bullet feet.
- All tables provided with stainless steel assembly hardware and are shipped knock-down.
- Custom sizes available.

Options / Accessories

- Solid stainless steel undershelf
- Perforated stainless steel undershelf
- Solid electropolished undershelf
- Perforated electropolished undershelf
- Welded construction

EAGLE GROUP

100 Industrial Boulevard, Clayton, DE 19938-8903 USA

Phone: 302-653-3000 • Fax: 302-653-2065

www.eaglegrp.com

Foodservice Division: Phone 800-441-8440

MHC/Retail Display Divisions: Phone 800-637-5100

For custom configuration or fabrication needs, contact our SpecFAB® Division.

Phone: 302-653-3000 • Fax: 302-653-3091 • e-mail: specfab@eaglegrp.com

EG04.02 Rev. 10/08

Spec sheets available for viewing, printing or downloading from our online literature library at www.eaglegrp.com

Eagle Foodservice Equipment, Eagle MHC, SpecFAB®, and Retail Display are divisions of Eagle Group. ©2008 by the Eagle Group



Profit from the Eagle Advantage®

Item No.: _____
 Project No.: _____
 S.I.S. No.: _____

Cleanroom Tables with Solid or Perforated Tabletop

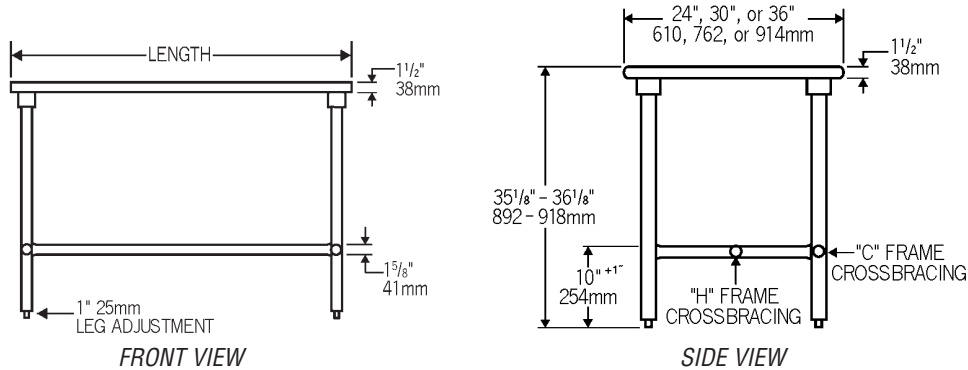

1) Select a tabletop.

Choose from the following:

Solid Tabletops		Perforated Tabletops		width		length		weight *	
electropolished model #	brushed stainless * model #	electropolished model #	brushed stainless * model #	in.	mm	in.	mm	lbs.	kg
SEP2424T	CRT2424T	EPCRT2424T	CRPT2424T	24"	610	24"	610	30	13.6
SEP2436T	CRT2436T	EPCRT2436T	CRPT2436T	24"	610	36"	914	40	18.1
SEP2448T	CRT2448T	EPCRT2448T	CRPT2448T	24"	610	48"	1219	50	22.7
SEP2460T	CRT2460T	EPCRT2460T	CRPT2460T	24"	610	60"	1524	58	26.3
SEP2472T	CRT2472T	EPCRT2472T	CRPT2472T	24"	610	72"	1829	76	34.5
n/a	CRT2484T	n/a	CRPT2484T	24"	610	84"	2134	80	36.3
n/a	CRT2496T	n/a	CRPT2496T	24"	610	96"	2438	101	45.8
n/a	CRT3030T	n/a	CRPT3030T	30"	762	30"	762	32	14.5
SEP3036T	CRT3036T	EPCRT3036T	CRPT3036T	30"	762	36"	914	42	19.1
SEP3048T	CRT3048T	EPCRT3048T	CRPT3048T	30"	762	48"	1219	55	24.9
SEP3060T	CRT3060T	EPCRT3060T	CRPT3060T	30"	762	60"	1524	66	29.9
SEP3072T	CRT3072T	EPCRT3072T	CRPT3072T	30"	762	72"	1829	79	35.8
SEP3084T	CRT3084T	EPCRT3084T	CRPT3084T	30"	762	84"	2134	91	41.3
SEP3096T	CRT3096T	EPCRT3096T	CRPT3096T	30"	762	96"	2438	112	50.8
SEP3636T	CRT3636T	EPCRT3636T	CRPT3636T	36"	914	36"	914	50	22.7
SEP3648T	CRT3648T	EPCRT3648T	CRPT3648T	36"	914	48"	1219	63	28.6
SEP3660T	CRT3660T	EPCRT3660T	CRPT3660T	36"	914	60"	1524	75	34.0
SEP3672T	CRT3672T	EPCRT3672T	CRPT3672T	36"	914	72"	1829	90	40.8
SEP3684T	CRT3684T	EPCRT3684T	CRPT3684T	36"	914	84"	2134	106	48.1
SEP3696T	CRT3696T	EPCRT3696T	CRPT3696T	36"	914	96"	2438	125	56.7

* For brushed stainless steel tabletops, add 10 lbs. to weight.

2) Select a base frame.

Shipped knocked down. Must be specified with your choice of tabletop.

Choose from the following:

- Stainless steel C-frame.
- Stainless steel H-frame.
- Electropolished C-frame.
- Electropolished H-frame.

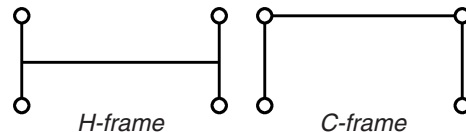

EAGLE GROUP
 100 Industrial Boulevard, Clayton, DE 19938-8903 USA
 Phone: 302-653-3000 • Fax: 302-653-2065
 www.eaglegrp.com

Foodservice Division: Phone 800-441-8440
 MHC/Retail Display Divisions: Phone 800-637-5100

Printed in U.S.A.
 ©2008 by Eagle Group

Rev. 10/08

Spec sheets available for viewing, printing or downloading from our online literature library at www.eaglegrp.com

Although every attempt has been made to ensure the accuracy of the information provided, we cannot be held responsible for typographical or printing errors. Information and specifications are subject to change without notice. Please confirm at time of order.