

Exterior

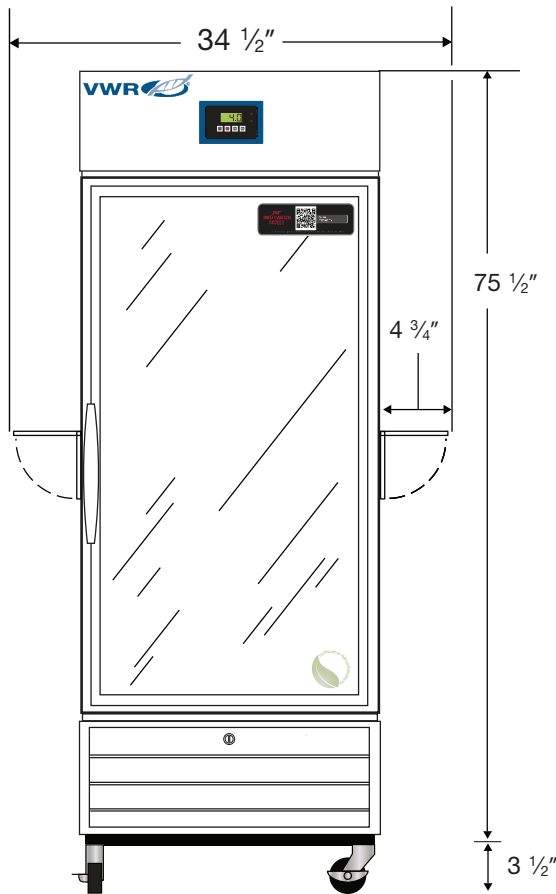

Front View



Side View

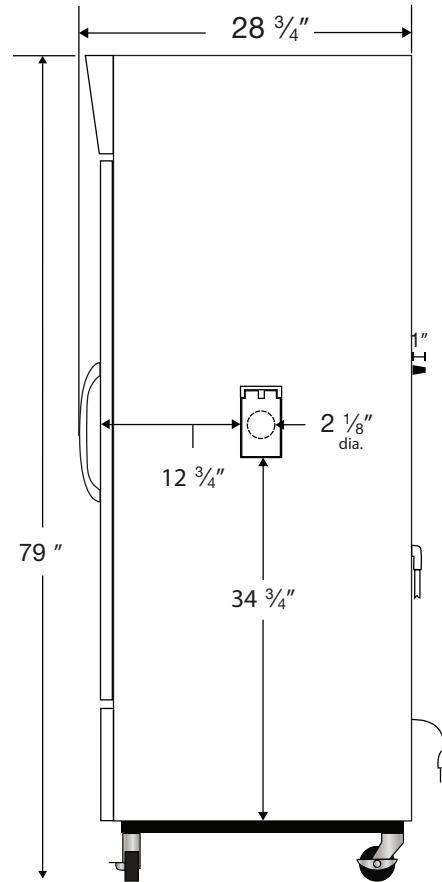

Top View

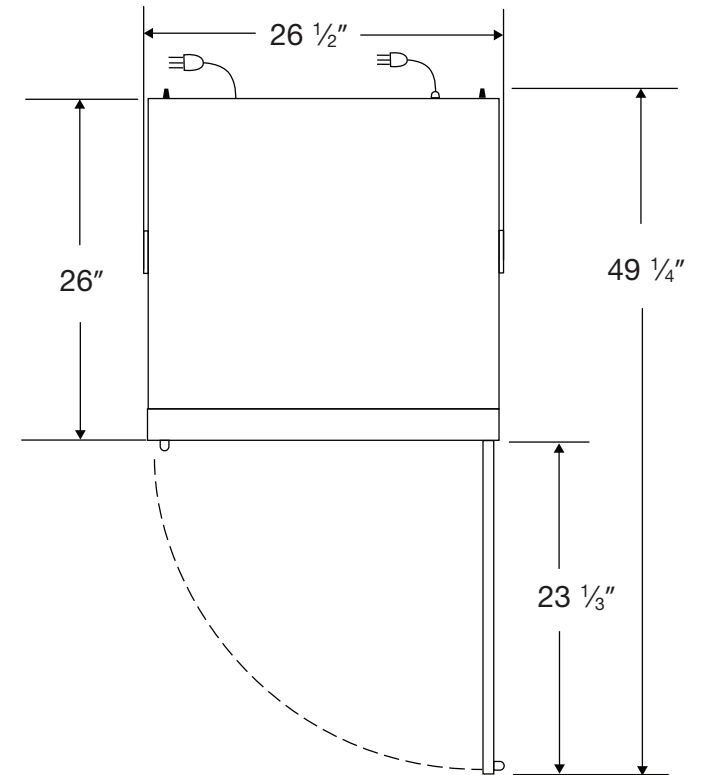
 115VAC/60Hz/1PH
NEMA-5-15P

Cat# 76514-298/VWR-HCCP-16

Cu.Ft.	Defrost	Door	Int Door	Shelves	W"	D"	H"	Refrigerant	H.P.	Amps	Weight
16	Cycle	1 Glass	0	3 Adj.	26 1/2	29 3/4	79	R290	1/5	3	243 lbs.