

WARRANTY

Use only MASTERFLEX precision tubing with MASTERFLEX pumps to ensure optimum performance. Use of other tubing may void applicable warranties.

The Manufacturer warrants this product to be free from significant deviations from published specifications. If repair or adjustment is necessary within the warranty period, the problem will be corrected at no charge if it is not due to misuse or abuse on your part, as determined by the Manufacturer. Repair costs outside the warranty period, or those resulting from product misuse or abuse, may be invoiced to you.

The warranty period for this product is two (2) years from date of purchase.

PRODUCT RETURN

To limit charges and delays, contact the seller or Manufacturer for authorization and shipping instructions before returning the product, either within or outside of the warranty period. When returning the product, please state the reason for the return. For your protection, pack the product carefully and insure it against possible damage or loss. Any damages resulting from improper packaging are your responsibility.

TECHNICAL ASSISTANCE

If you have any questions about the use of this product, contact the Manufacturer or authorized seller.

OPERATING MANUAL

MASTERFLEX® L/S®

EASY-LOAD® II PUMP HEADS

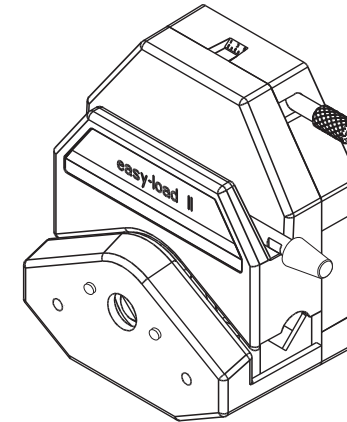

MASTERFLEX®

(US & Canada only) Toll Free 1-800-MASTERFLEX • 1-800-637-3739

(Outside US & Canada) 1-847-381-7050

www.masterflex.com • techinfo@masterflex.com

*EN809 manufactured by:

Masterflex LLC

28W092 Commercial Avenue

Barrington, IL 60010

A-1299-0620B
Edition 17

MASTERFLEX®

(US & Canada only) Toll Free 1-800-MASTERFLEX • 1-800-637-3739

(Outside US & Canada) 1-847-381-7050

www.masterflex.com • techinfo@masterflex.com

SAFETY PRECAUTIONS



WARNING: PRODUCT USE LIMITATION

This product is not designed for, nor intended for use in, patient-connected applications; including, but not limited to medical and dental use and, accordingly, has not been submitted for FDA approval.

NOTE: Use only MASTERFLEX precision tubing with MASTERFLEX pumps to ensure optimum performance. Use of other tubing may void applicable warranties.

WARNINGS: Turn drive off before removing or installing tubing. Fingers or loose clothing could be caught in the rollers.



Stop the drive when changing tubing or its position in the rotor mechanism (the rotor is partially exposed when the **LOADING LEVER** is in the open position).

EXPLANATION OF SYMBOLS



CAUTION: Risk of danger. Consult the Operator's Manual for nature of hazard and corrective actions.



CAUTION: Risk of crushing. Keep fingers away from rotor while pump is in operation. Stop pump before loading or unloading tubing.

PUMP FOR LIQUIDS ORIGINAL INSTRUCTIONS

MAINTENANCE AND CLEANING

No lubrication is required for the L/S EASY-LOAD II Pump Head.

Use a mild detergent solution to clean the pump head.

Do not immerse nor use excessive fluid.

To disassemble pump head for cleaning — See REPLACING ROTOR instructions.

Repair is limited to the replacement of the rotor assembly. Contact dealer for further repair information.

See REPLACEMENT PARTS AND ACCESSORIES for parts ordering information.

REPLACING ROTOR

1. Remove pump head from drive.
2. Remove rear cover of pump head.
3. Remove the two screws shown in **Figure #7**.
4. Remove rotor assembly.
5. Install new rotor assembly and secure with two screws.
6. Reinstall rear cover.

Figure #7. Replacing Rotor

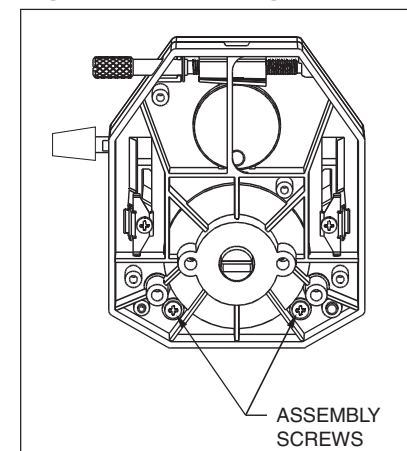

REPLACEMENT PARTS AND ACCESSORIES

Rotor assembly

Pump Head Number	Order No.	Pump Head Number	Order No.
77200-50	77200-58	77200-52	77200-59
77202-50	77200-58	77200-62	77200-69
77200-60	77200-68	77201-62	77200-69
77202-60	77200-68	77200-82	77200-89
77201-60	77200-68		
77200-80	77200-88		

Mounting hardware for L/S Easy-Load II Pump Heads

Set contains #8-32 screws, washers and wing nuts (in two-, three-, and four-head hardware).

Number of heads to be mounted	Stainless steel order number
1	77200-01
2	77200-02
3	77200-03
4	77200-04

Tubing Retainer Kit

Pump Head Number	Order No.
77200-50, 77200-60, 77201-60	77200-90
77200-52, 77200-62, 77201-62	77200-92
77202-50, 77202-60	77200-94

OCCLUSION ADJUSTMENT (on 77201-60, -62 models only)

Adjust occlusion setting near top of pump head. **(Figure #5.)**

“4” for nominal performance;

“5” for increased pressure/vacuum with reduced tubing life;

“2” or “3” for longer life with less pressure and vacuum.

NOTE: For optimum performance, turn knob to “1” after loading. Start drive and adjust knob until pump primes and fluid begins to flow.

NOTE: Occlusion usually does not need to be readjusted when changing tubing.

Figure #5. Adjust Occlusion

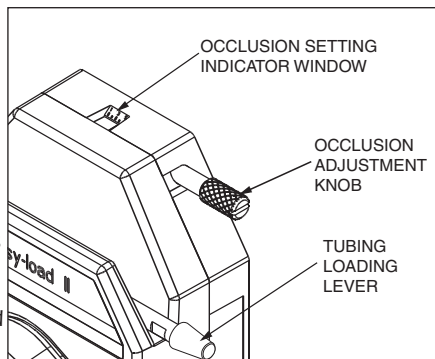

MULTI-CHANNEL MOUNTING

L/S EASY-LOAD II Pump Heads can be mounted in tandem (up to four), depending on the torque capabilities of the drive. **(See Figure #6.)**

Special mounting hardware is required.

See REPLACEMENT PARTS AND ACCESSORIES for mounting hardware.

Figure #6. Multi-channel Mounting

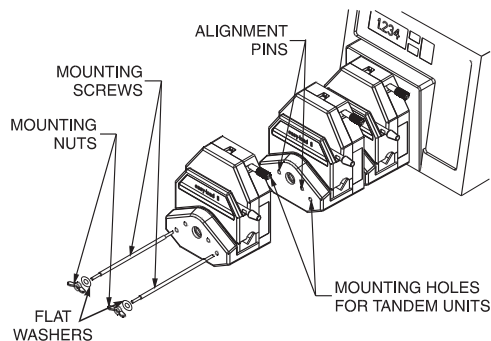

CAUTION: DO NOT OVER-TIGHTEN SCREWS OR WING NUTS.

NOTE: The L/S EASY-LOAD II Pump Head can be used in any combination with other L/S EASY-LOAD Pump Heads. The longer L/S EASY-LOAD II mounting hardware is required (not supplied).

NOTE: The tubing on the inside L/S EASY-LOAD II Pump Head(s) can be changed.

SPECIFICATIONS

Pump Head Number	Pump Material	Occlusion	Shaft Length	L/S [®] Tubing
77200-50	PPS/CRS	Fixed	Short	L/S [®] 13,14,16,25,17,18
77202-50	PPS/CRS	Fixed	Short	L/S [®] 13,14,16,25
77200-52	PPS/CRS	Fixed	Short	L/S [®] 15,24,35,36
77200-60	PPS/SS	Fixed	Short	L/S [®] 13,14,16,25,17,18
77202-60	PPS/SS	Fixed	Short	L/S [®] 13,14,16,25
77200-62	PPS/SS	Fixed	Short	L/S [®] 15,24,35,36
77200-70	PPS/CRS	Fixed	Long	L/S [®] 13,14,16,25,17,18
77200-72	PPS/CRS	Fixed	Long	L/S [®] 15,24,35,36
77200-80	PPS/SS	Fixed	Long	L/S [®] 13,14,16,25,17,18
77200-82	PPS/SS	Fixed	Long	L/S [®] 15,24,35,36
77201-60	PPS/SS	Adjustable	Short	L/S [®] 13,14,16,25,17,18
77201-62	PPS/SS	Adjustable	Short	L/S [®] 15,24,35,36

Typical Flow, Pressure and Vacuum Data

L/S [®] Tubing	Flow rate		Max. Discharge Pressure* psig (bar)	Vacuum* @ 600 rpm in (mm) Hg	Suction Lift* @ 600 rpm ft (m) H ₂ O
	@1 rpm mL/Rev	@ 600 rpm mL/min			
L/S [®] 13	0.06	36	40 (2.7)	26 (660)	29 (8.8)
L/S [®] 14	0.22	130	40 (2.7)	26 (660)	29 (8.8)
L/S [®] 16	0.80	480	40 (2.7)	26 (660)	29 (8.8)
L/S [®] 25	1.7	1000	35 (2.4)	26 (660)	29 (8.8)
L/S [®] 17	2.8	1700	20 (1.4)	20 (510)	22 (6.7)
L/S [®] 18	3.8	2300	5 (1.0)	20 (510)	22 (6.7)
L/S [®] 15	1.7	1000	40 (2.7)	26 (660)	29 (8.8)
L/S [®] 24	2.8	1700	40 (2.7)	26 (660)	29 (8.8)
L/S [®] 35	3.8	2300	35 (2.4)	26 (660)	29 (8.8)
L/S [®] 36	4.8	2900	20 (1.4)	24 (610)	27 (8.3)

Number of rollers:	4
Maximum pump speed (rpm):	600
Nominal torque load—Running:	up to 90 oz-in (6.5 kg·cm)
Housing materials:	Polyphenylene sulfide (PPS), acetal, nylon
Roller materials:	Cold-Rolled Steel (CRS) / Stainless Steel (SS)
Bearing materials:	Cold-Rolled Steel (CRS) / Sealed Stainless Steel
Rotor materials:	Stainless Steel (SS)
Operating Temperature[‡]:	32°F to 104°F (0°C to 40°C)
Storage Temperature:	−49°F to 149°F (−45°C to 65°C)
Humidity:	0% to 90% (non-condensing)
Dimensions (W x H x D):	
Operating:	4 in x 4-3/4 in x 2-3/4 in (102 mm x 121 mm x 70 mm)
Open:	4 in x 5-1/2 in x 2-3/4 in (102 mm x 140 mm x 70 mm)
Weight:	1.4 lb (0.6 kg)
Noise level:	<70 dBA @ 1 meter
Compliance (for CE mark):	EN809 (EU Machinery Directive)

*As tested with NORPRENE[®], PHARMED[®] BPT, and TYGON[®] tubing.
Values will be less with silicone and C-FLEX[®].

[‡] Use in this temperature range for continuous duty operation with no decrease in performance or product life. Pump heads will work outside this range with some possible reductions in performance or product life.

INTRODUCTION AND GENERAL DESCRIPTION

This L/S EASY-LOAD II Pump Head, when combined with a MASTERFLEX® L/S® drive or compatible system, is designed to provide a simple, easy-to-use peristaltic pump system. The pump head accepts several different tubing sizes for a wide range of flow rates. The unique over-center cam design and automatic tubing retention allow quick tubing changes and greatly reduced maintenance time.

Each pump is supplied complete with a 15 in (38-cm) length of tubing, one mounting hardware package and this manual. A flat-bladed screwdriver or Phillips is required to complete installation.

DRIVE COMPATIBILITY AND SETUP

The L/S EASY-LOAD II Pump Head is compatible with most MASTERFLEX® L/S® drives with a standard tang interface. Mount the pump head using the 2 screws provided.

(See Figure #1.)

Figure #1. Setup

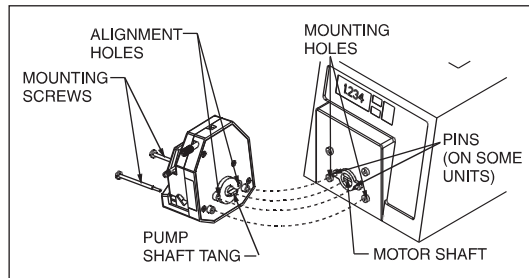

TUBE LOADING

1. Be sure the pump drive is turned off.
2. Rotate the lever to the left to open the pump.
3. Load the correct size tubing. Center the tubing between the retainers.

(Figure #2)

4. Rotate the lever to the right to close.

(Figure #3)



WARNING: Stop the drive when changing the tubing or its position in the rotor mechanism (the rotor is partially exposed when the LOADING LEVER is in the open position).

NOTE: For optimum tubing life, keep tubing straight where it enters and exits

Figure #2. Open and Load

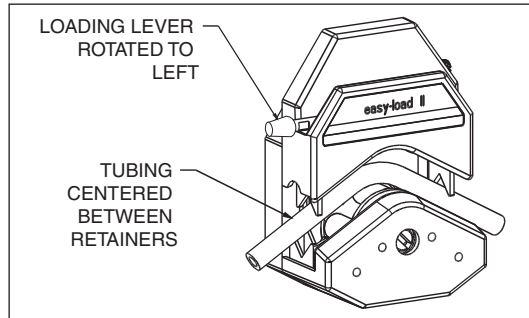
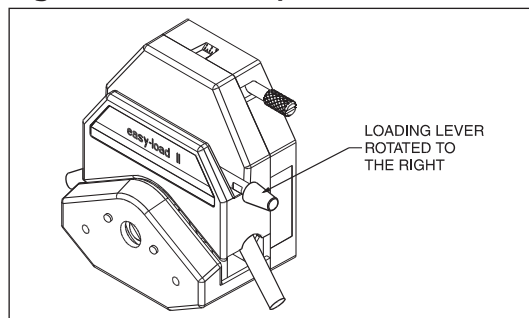

Figure #3. Close Pump



2 CHANNEL L/S® EASY-LOAD® II

TUBE LOADING MODELS 77202-50, -60

Use two tubes—sizes L/S® 13, L/S® 14, L/S® 16 OR L/S® 25.

For proper tube retention, both tubes must be the same size and material.

Figure #4. 2 Channel Tube Loading

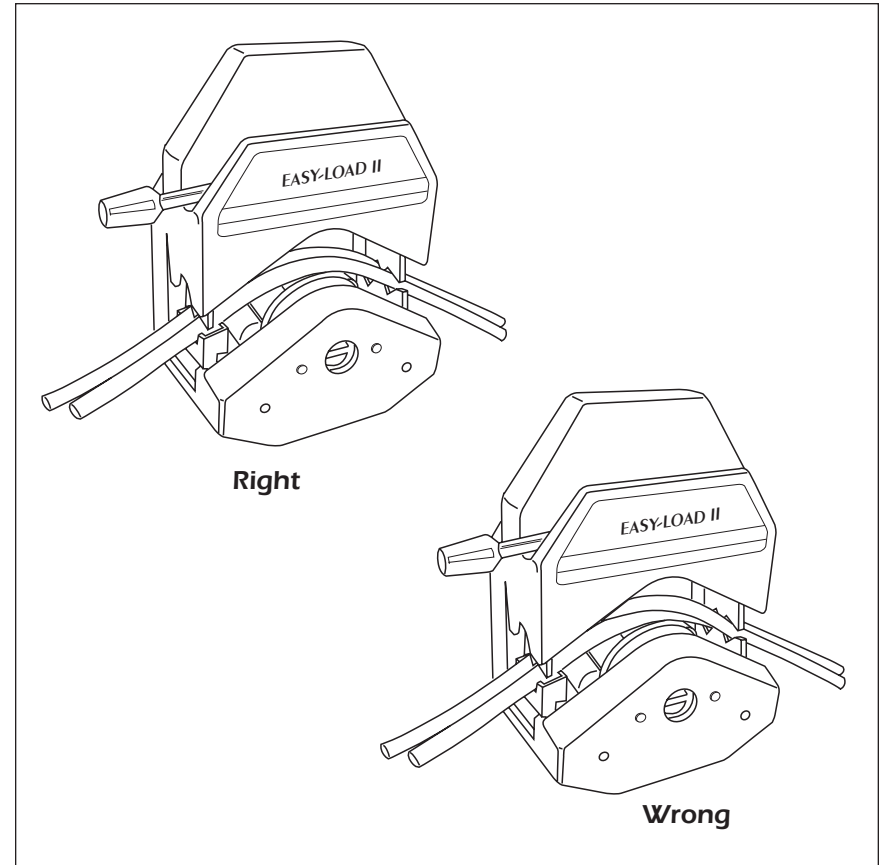

CAUTION: Tubes must not cross inside pump head!