

Product datasheet

CaptairBio 321

PCR Workstation

Complete protection for RNA/DNA amplification

Featuring a high efficiency filtration system that provides a particulate free atmosphere around the manipulation. A high energy UV light is used to decontaminate the worktop from biological cross-contamination between operations.

Particulate free workstation

- Protect against external contamination
- Internal air quality achieved by high efficiency particulate filter(s) (HEPA H 14 / ULPA U16)
- Carbon filter (optional) to protect handlings from VOCs present in the laboratory atmosphere

UV decontamination

- Protect your samples from cross-contamination
- Powerful UV decontamination (254 nm lamp power)
- Adjustable timer
- Automatic UV lamp off switch in case the sash is opened when the UV light is on

Easy to clean

- Work surface is easy to clean
- Seamless worktop with smooth corners, available in TRESPA®TopLab^{PLUS} or Stainless steel (304 L)
- Low porosity material

Ergonomic design

- Slanted sash provides an ergonomic position for comfort and productivity
- Compact tubular fluorescent lighting
- Side panel utility ports allow electrical cables and/or fluid lines to enter the enclosure with ease.



Download our
eGuard application



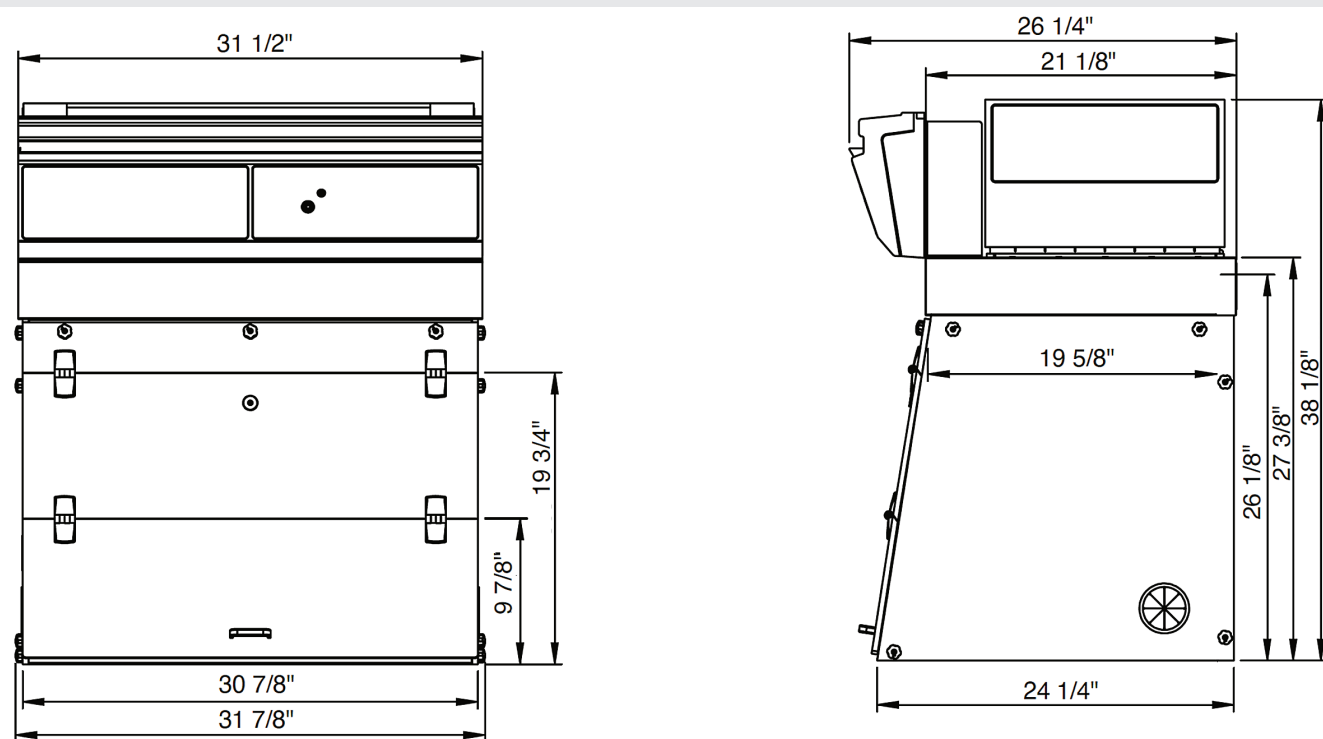

Please add 6" between the last filter and the ceiling to allow for good air recirculation and to replace filters easily.

Work surfaces with built in spill tray

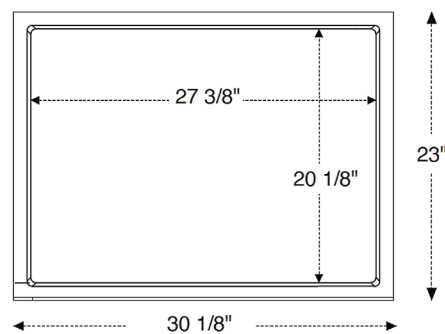

TRESPA® TopLab^{PLUS}

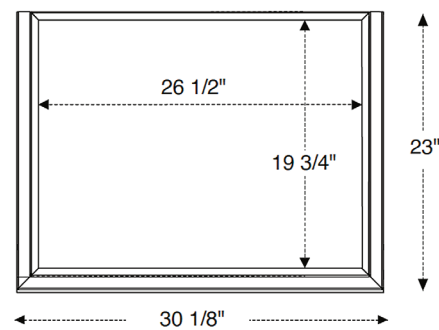

Stainless steel 304 L

Benchcap: fixed work bench

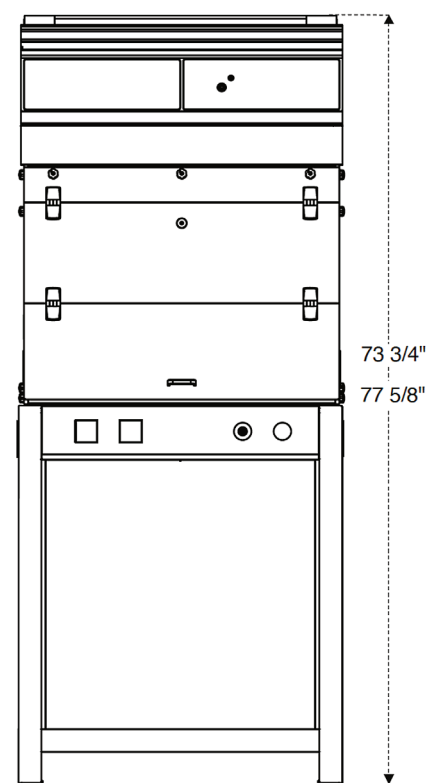

* For Mobicap: rolling cart deduct 1"

Model	1P	1C1P
SAFETY STANDARDS	NF EN61010 - CE MARKING - EN 1822-1998 (HEPA H14 & ULPA U17 Filters)	
External Width	31 7/8"	
External Depth	24 1/4"	
External Height (min./max.)	38 1/8" - 42"	
Internal Width	30 7/8"	
Internal Depth (min./max.)	19 5/8" - 20 1/8"	
Internal Height	23 3/8"	
Voltage/Frequency (V-Hz)	100-240 / 50-60	
Air face velocity (m/s)	68 fpm	
Air flow (m ³ /h)	117 cfm	144 cfm
Power Consumption (W)	40	45
Decibel Level (dBA)	54	57
Side and front panels	10 mm thick synthetic glass is designed to protect users from harmful UV rays and β (Bêta) emitted from radioactive isotopes such as: T(3H), 14C, 32P	
Structure	Corrosion resistant electro-galvanized steel coated with anti-acid polymer	
Filtration Module	Polypropylene	

Filtration

Particulate filter (1P)	HEPA H14 : This filtration technology traps particles larger than 0.1 µm with 99.995% efficiency according to the MPPS method set forth in the EN 1822-1 standard. ULPA U17 : This filtration technology traps particles larger than 0.1 µm with 99.99995% efficiency according to the MPPS method set forth in the EN 1822-1 standard.
Carbon filter (optional) (1C)	Adding a carbon filter to your enclosure allows protection of your samples from VOCs. AS filter: For organic vapors.
Particulate pre-filter	Protect particulate filters from dust contained in the laboratory environment (only for 1P version)

Features

Bactericidal UV Lights	15W - Wavelength: 254 nm 0.08 mJ/ s/cm ²
Internal lighting	LED - IP 44 - 6000k 900 lux
eGuard app (Android or IOS)	Mobile app for real time remote control of Smart devices
Connectivity	RJ45 cable connection to view and change workstation settings (cable included)
Anemometer	Monitors a drop in pressure that indicates pre-filter or filter replacement is required
Side panel utility ports	2 per unit

Accessories

Benches	Rolling cart (Mobicap) or fixed bench (Benchcap)
Shelves	Internal metal sliding shelf (only for Benchcap)
Worktop	TRESPA® TopLab ^{PLUS} , Glass or 304L Stainless Steel
Molecode S	Automatic detection of VOC filter breakthrough



Erlab's state of the art Research & Development Laboratory relies exclusively on filtration

About Erlab

We provide safety, we protect your health

Erlab invented the ductless fume hood in 1968. With more than 50 years of experience in the field of chemical filtration and protection of laboratory personnel; we know the formula for safety. With Erlab, you will never have to wonder or worry if our products are safe. We build each one of the following 7 ingredients into our products, and without all of them, your health and safety will be compromised.

1 Erlab R&D Laboratory

The engineers and chemists in our state-of-the-art R&D laboratory understand molecular filtration. We are committed to designing products that are safe and of the highest quality, strive to improve our products, and continuously develop new products that provide greater protection in the laboratory.

2 Strict Safety Standards

We hold ourselves to the highest standard and adhere to the strict AFNOR NF X 15-211: 2009 filtration safety standard as cited by ANSI Z9.5-2012.

3 A Published Chemical Listing

It all begins here. Without this listing, we are not compliant with AFNOR NF X 15-211. Our in-house laboratory tests, as well as independent testing, to verify the retention capacity of over 700 chemicals for our filters.

4 Independent Testing

Erlab filters have been independently tested multiple times at various concentrations guaranteeing that our safety solutions all adhere to the strict performance criteria of the AFNOR NF X 15-211:2009 standard assuring that the emission concentration at the filter exhaust will always be lower than 1% of the TLV.

5 Application Questionnaire (Valiquest)

Our laboratory specialists will recommend the appropriate filtration fume hood, type of filter, and personalized advice.

6 Certificate of Validation for the chemicals used in the hood

A certified PhD chemist issues a Certificate of Validation with a list of the chemicals approved for use in the hood.

7 Our Safety Program

We back up our products 100%. This program includes your specialized chemical evaluation, validation of your hood upon installation, and a filtration safety specialist at your service to ensure that your hood is operating to its full potential.



VWR.COM

Prices, product, and/or services details are current when published and subject to change without notice. | Certain products or services may be limited by federal, state, provincial, or local regulations. | VWR, part of Avantor, makes no claims or warranties concerning sustainable/green products. Any claims concerning sustainable/green products are the sole claims of the manufacturer and not those of VWR International, LLC and/or Avantor, Inc. or affiliates. All prices are in US dollars unless otherwise noted. Offers valid in US and Canada unless otherwise noted, void where prohibited by law or company policy, while supplies last. | Trademarks are owned by Avantor, Inc. or its affiliates, unless otherwise noted. | Visit vwr.com to view our privacy policy, trademark owners, and additional disclaimers. © 2021 Avantor, Inc. All rights reserved.