



STIRLING[™]
ULTRACOLD



SU105UE -86°C Ultra-Low Storage

Operating Manual

02.06.19



THIS PAGE INTENTIONALLY LEFT BLANK



SU105UE Quick Guide

Initial Setup

1. Unpack freezer unit and included components, ensure all packaging material has been removed from around the fan inlet and outlet holes.
2. Plug AC power cord into the main power socket at the back of the unit and then into an electrical outlet.
3. Turn the AC power switch to the "On" position.
4. **Notice:** Ensure the access port stopper or sealant is in place. Remove factory tape at the port stopper prior to initial use.
5. Turn on battery power. Battery switch is located in main power housing on the rear of the freezer.
6. Ensure setpoint is within desired range (default is -86°C) or change setpoint to user-preferred temperature according to the control functions outlined below.

Guide to Basic GUI Functions

ON / OFF	Switch the main power on, located at the back of the unit above the AC cord.
Battery Power	Switch on the battery power located on the left of the Recessed Electrical Panel. This is essential if monitoring is required in the event of a power failure.
Change Setpoint	Tap Home > Setup > Setup > Enter PIN > Enter > Change > Setpoint > +/- > Save
Silence Alarm	Tap Home > Setup > Silence
Event Log	Tap Home > Setup > Event Log > Prev. Page, Next Page
Chart History	Tap Home > Setup > Chart History

Guide to Advanced GUI Functions

Alarm Setup	Tap Home > Setup > Setup > Enter PIN > Enter > Alarms > xxx Delay > +/- > Save
Date and Time	Tap Home > Setup > PIN > Date & Time > +/- > Save
Change PIN	Tap Home > Setup > Setup > Enter PIN > Enter > PIN > Enter New PIN > Enter > Re-enter New PIN > Enter
Calibrate RTDs	Tap Home > Setup > About > Service > RTD Calibr. > RTD Select > +/- > Calib.

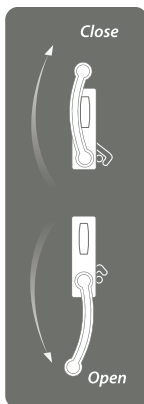

Notice:

Before engaging door latch, ensure handle is fully rotated down to the stop point in order to reset latching mechanism. To engage door latch when closing, push outer door IN before rotating door handle to UP position.

THIS PAGE INTENTIONALLY LEFT BLANK



SU105UE

-86°C Ultra-Low Storage

The model SU105UE incorporates next generation free-piston Stirling engine technology. Free-piston Stirling engine technology differs from conventional compressor-based refrigeration by providing high efficiency, deep-temperature cooling in a lightweight package.

Table of Contents:

1. INTRODUCTION	6-7
1.1 Description	6
1.2 Intended Uses	6
1.3 Documentation	6
1.3.1 Operating Manual	6
1.4 Organization of this Operating Manual	7
2. FEATURES OF THE SU105UE FREEZER	8-11
2.1 Free-Piston Stirling Engine	8
2.2 Cabinet Design Features	8
2.3 Temperature Monitoring Features	8
2.4 Graphical User Interface (GUI)	9
2.5 Pictorial Tour	10
2.6 Included Items	10
2.7 Options	11
2.7.1 Adapter Installation Procedure	11
2.7.2 Power Cord Change	11
3. SAFETY PRECAUTIONS	12-13
4. UNPACKING AND INSTALLATION	14-15
4.1 Freezer Site Qualification	14
4.2 Setup	15
5. OPERATION	16-31
5.1 Operation of the SU105UE Freezer	16-29
5.1.1 Graphical User Interface (GUI) & PIN	17
5.1.2 GUI Menu	18
5.1.3 Basic GUI Controls	19
5.1.4 GUI Instructions	20-29
5.2 Managing Freezer Contents	30
5.3 Cleaning	30
5.4 Calibration of the RTDs	31
6. TRANSPORTING, MOVING AND STORAGE	31
7. SPECIFICATIONS	32-34
7.1 Freezer Specifications	32-33
7.2 Materials Specifications	34
8. TROUBLESHOOTING	35
9. WARRANTY	36-37
10. CE DOCUMENTATION	38

EU Authorized Representative:

Global Cooling, BV
Lage Dijk 22,
Helmond, 5705 BZ
The Netherlands

1. Introduction

1.1 – Description

The Stirling Ultracold SU105UE free-piston Stirling engine Ultra-Low Temperature (-86°C) Freezer uses proven M150A free-piston Stirling engine technology to provide high efficiency, deep-temperature cooling.

1.2 – Intended Uses

The SU105UE freezer provides ultra-low temperature storage for general (non-flammable) research laboratory materials requiring a stable, computer-controlled, deeply-frozen environment. The storage of blood or blood products intended for medical purposes is prohibited.

1.3 – Documentation

1.3.1 – Operating Manual

- This operating manual describes all aspects of receiving, installing, use, moving and storage of the Stirling Ultracold SU105UE Freezer. More detail on specific aspects of operation of the freezer is available via online supplementary documentation.
- Performance of the freezer is controlled by electronic logic that is programmed through a touch screen Graphical User Interface (GUI). This operating manual describes use of the GUI in section 5.

User Advisory:

Deep temperatures are dangerous, use proper precautions when operating ultra-low temperature freezers. This ultra-low temperature freezer is intended for storage of frozen sample product or vials at deep temperatures. Stirling Ultracold, Division of Global Cooling, Inc. cannot be held responsible for damages or loss of stored product attributed to unintended use. In no case will Stirling Ultracold, Division of Global Cooling, Inc. be held liable for loss of stored product resulting from electrical, mechanical or structural failure. As with any ultra-low temperature freezer, appropriate back-up and redundancy considerations are the responsibility of the user.



1.4 – Organization of this Operating Manual

This manual is organized as follows:

- Unpacking and installation
- Set-up
- Operation
- Transporting and moving

Please note that precautions and safety instructions are part of each section of the manual, and must be observed to avoid damage to the freezer or harm to its users.

Flammable Refrigerant Use:

SU105UE uses 30-33 grams of R-170 (Ethane) in hermetically sealed thermosiphon tubing. It requires caution in use/repair.

A. Danger – Risk of Fire or Explosion. Flammable Refrigerant Used. **Do Not Drill or Puncture Inner Liner.**

B. Danger – Risk of Fire or Explosion. Flammable Refrigerant Used. **To be Repaired Only by Trained Service Personnel.** Component Parts Shall Be Replaced With Like Components. Do Not Puncture Refrigerant Tubing.

C. Caution – Risk of Fire or Explosion.
Flammable Refrigerant Used. **Consult Repair Manual/Owner's Guide Before Attempting to Service this Product.**
All Safety Precautions Must be Followed.

D. Caution – Risk of Fire or Explosion.
Dispose of Properly in Accordance with Federal or Local Regulations.
Flammable Refrigerant Used.

E. Caution – Risk of Fire or Explosion
Due to Puncture of Refrigerant Tubing;
Follow Handling Instructions Carefully. Flammable Refrigerant Used.



*Two Model SU105UE cabinets stacked.
Shown with optional stacking adapter.*

2. Features of the SU105UE freezer

2.1 – Free-Piston Stirling Engine

The SU105UE Ultra-Low Temperature Freezer uses the state of the art Stirling Ultracold Model M150A free-piston Stirling engine to provide high efficiency, deep-temperature cooling. No HCFC or CFC refrigerants are used in the M150A and SU105UE. The M150A Stirling cycle engine uses approximately 2 grams of helium gas as a working fluid. 30-33 grams of R-170 are used in the thermosiphon which removes energy from the freezer.

2.2 – Cabinet Design Features

The cabinet is VIP insulated with polyurethane foam support providing an internal volume of cabinet approximately 105 liters. The environmentally friendly, SNAP-compliant blowing agent is Ecomate®. A locking cam door latch ensures door gasket compression when closed. Door sealing consists of three gaskets and is factory replaceable. A door defrost minimizes water or ice deposition on the gasket interface.

2.3 – Temperature Monitoring Features

Two resistance temperature detectors (RTDs) measure the internal cabinet temperature of the SU105UE. One provides input to the free-piston Stirling engine controller and the other provides input for the Graphical User Interface (GUI) display and for reporting and logging. The display RTD may be user calibrated through the GUI. The GUI provides a door open timeout alarm and monitors the temperature reporting RTD for excursions beyond high and low limits that are set automatically or manually. Alarms are reported through an audible alarm in the freezer enclosure and through a contact closure that may be connected to an external alarm. The GUI provides options to temporarily suppress alarms and set a delay time before the alarm is reported via the contact closure. A one-time temperature alarm suppression provided by the software allows for the initial cooling of the freezer after start-up.



2.4 – Graphical User Interface (GUI)

The GUI is implemented on a touch screen control panel on the front of the cabinet. Its capabilities are described in detail later. General features of the control panel are:

- Set freezer control, alarm and communications parameters
- Provide password protected access to parameter changes
- Display freezer status
- Display temperature graph and event log
- Display diagnostic and service information
- Display freezer identification information

Values for the following SU105UE parameters are viewed and modified through the touch screen.

Modifiable Values	Accessible Values
Temperature setpoint	Current freezer interior temperature
Under temperature limit	Temperature history chart
Over temperature limit	Interior vs. free-piston Stirling engine temperatures
Over temperature delay after door opening	Alarm status
Audible alarm silence interval	GUI firmware event log
External contact delay upon alarm	"About" screen (general information)
Door open alarm delay	Service contact information
Door defroster status	Diagnostics screen
Door auto-defrost status	
Manual defrost time	
Password Identification Number (PIN) status	
Current date	
Current time	
RTD calibration adjustments	

2.5 – Pictorial Tour

1. Control Panel
2. Locking Latch
3. Door Gasket
4. Fixed Stainless Steel Shelf
5. Air Inlet
6. Access Port
 - For thermocouple wires, purge gas, etc.
 - 0.5" (12.7 mm) with plug
7. Air Outlet
8. Recessed Electrical Panel
 - A. AC Power Connector
 - B. AC Power Switch
 - C. External Alarm Terminal Strip, Dry Contacts (NC, NO, C)
 - D. Battery Power Switch



Model SU105UE. Shown with optional stainless steel inventory racks.

2.6 – Included Items

- Packing List
- Operating Manual - (this document, including Warranty Card). 1 pc
- Port Sealant
- 1 Port Plug
- 2 Keys
- 1 Wrench



2.7 – Options

• Stacking Adapter

When stacking two Stirling Ultracold SU105UE free-piston Stirling engine Ultra-Low Temperature (-86°C) Freezers, a stacking adapter is required. The Stacking Adapter consists of two (2) plates and twelve (12) screws.

2.7.1 – Adapter Installation Procedure

1. Remove rear casters from both freezers. Install adjustable leveling feet.
2. Move 2nd unit over the top of 1st unit sitting on floor.
Note the net weight is about 220 lbs. Three person job.
3. Adjust height if necessary.
4. Level top freezer.
5. Attach stacking plate and tighten six screws (torque 8 to 10 lb-in) at both sides.
Note that the stacking plate should not hold the weight of upper unit. The upper unit should sit on the leveling feet.

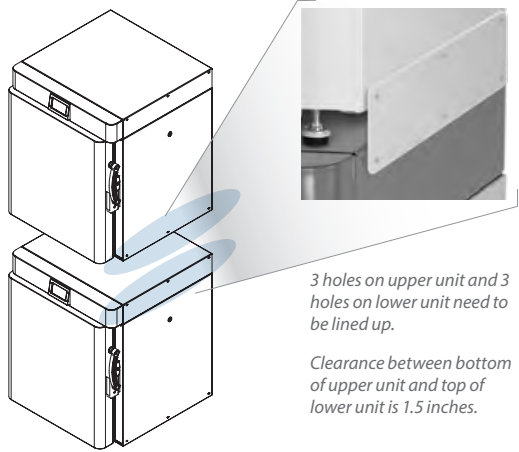

• Power Cords

A simple line cord change can allow for multiple power and receptacle types.

2.7.2 – Power Cord Change

To change the line cord, unplug the old line cord from the AC Power Connector found on the rear of the unit and plug the new line cord in its place. Make sure to use the cord and plug appropriate for your location.

The options below are available:

1. Line Cords for North America. 120V, AC, 60Hz. NEMA 5-15P plug. Requires standard NEMA 5-15R receptacle.
2. Line Cords for Europe/International. 240V, AC, 50Hz. Standard two-pin plug requires two-pin receptacle.

3. Safety Precautions

Potential hazards associated with use of the SU105UE freezer may impact the safety of persons in the workplace in which the freezer is installed. This includes persons who operate the freezer, and other personnel in its vicinity. The freezer itself may also be damaged or its warranty voided by improper operation or usage. It is very important that all personnel that install, operate, transport or place the freezer into storage read this entire manual to understand those hazards. Likewise, it is imperative to place this manual for ready reference adjacent to the freezer at all times.

Specific appropriate precautions are included in each section of this operating manual. However, several important general precautions must be observed and are described below.

- **Do not** disassemble, modify or repair. There are no user serviceable parts inside the freezer unit.*
- **Do not** operate freezer with the top cover removed as this will affect freezer performance. To avoid risk of electrical shock and injury disconnect power before removing top cover.
- **Do not** immerse in water, pour water on the unit, or operate where water may drip or fall on the unit. Operation under extreme environmental conditions, e.g., in very high humidity environments (RH 85% or more) also may lead to condensation or water intrusion.*
- **Warning:** Unauthorized modification to the cabinet, controls or free-piston Stirling engine will void all warranty provisions.
- **Do not** cut, change or modify the power cable.*
- **Do not** store flammable items such as gasoline, thinner or solvents in the freezer.
- The freezer is NOT rated as an explosion-proof freezer.
- **Do not** use hard and/or sharp objects, such as knives, screwdrivers, etc. to remove any frost or ice that has accumulated on the inside of the freezer. The inside panels are heat exchangers and can be damaged. Defrosting the cabinet is described later in this operating manual.

**Doing so will void the warranty.*

- **Do not** use solvents to clean the panel or the outside or inside of the freezer.
- When removing the power cable, hold onto the plug and not the cable.
- **Do not** block the air intake or air discharge vents used by the free-piston Stirling engine (See pictorial on Page 10 for locations.)
- Ultra-low temperature freezers are different from home freezers in that at -86°C frostbite can occur instantly.
- For the personal safety of freezer users, safe operating procedures are essential.
 - **Never** handle samples or freezer accessories with bare hands. Be especially careful not to spill ultra-low temperature materials onto skin or clothing.
 - **Do not** use gloves that become brittle at ultra-low temperatures.
 - Nitrile and latex gloves are inadequate.
- Permeable gloves are dangerous because frozen materials can contact skin and cause damage.
 - Be especially careful that materials at low temperatures are not spilled onto skin or clothing.
- Ultra-low temperatures may adversely impact freezer contents:
 - Do not put ice or liquid water directly in the freezer box; always use suitable containers.
 - Use only sample containers that have been approved or tested for ultra-low temperature use.
 - Do not use glass containers when the contents might freeze and expand.
 - Some plastics shatter at ultra-low temperatures. Avoid splinter hazards.
 - Biological and chemical hazards are still hazardous at ultra-low temperatures. Always wear proper protective equipment and follow appropriate isolation protocols.
 - Many types of labels will fall off and/or break at ultra-low temperatures. Some types of ink which stick to glass and/or plastic at room temperature lose adhesion at ultra-low temperature.
- In addition to the ULT hazards above, there are also physical hazards to consider:
 - Be cautious when closing the door to avoid a pinching hazard.
 - Be careful when loading the cabinet with heavy items.

4. Unpacking and Installation

Verify the SU105UE freezer shipment by uncrating the freezer and included items, inspecting them for damage during shipping, and compare the items to the packing list for completeness.

4.1 – Qualify the installation site for the freezer before placing it into service.

1. Note the shipping packaging dimensions (H x D x W) of 1041.4 x 787.4 x 787.4 mm | (41 x 31 x 31 in) and shipping weight of 121 kg | (266 lbs.), crated ocean weight of 180 kg | (396 lbs.).
2. When moving the shipment from the point of receipt to the place where it will be uncrated. The installation site must accommodate the freezer exterior dimensions of (H x D x W) 864 x 711 x 686 mm | (34 x 28 x 27 in) and weight of 100 kg | (220 lbs.).
3. There are no specific required clearances for the top, back and sides of the freezer; however allowances must be made for electrical connections to the panel on the back of the freezer.
4. Ingress to the access port (see Page 10) is required during normal operation.
5. The freezer must be installed on a nominally level surface and leveling feet will accommodate small variations from level. SU105UE freezers are stackable up to two high. Requires optional stacking adapter.
6. The aisle way into which the freezer door opens must be wide enough to allow access to the contents of the freezer and not present a hazard to those using the aisle way.
7. The facility/room lighting must not obscure the readability of the touch screen display and must provide good visibility for working with the contents of the freezer.
8. After the freezer is placed into its installation location, any blockages to the air inlet and outlet must be removed. (See Page 10 for locations.)
9. Care must be taken while unpacking and installing the freezer not to injure personnel or damage the freezer by loss of control of its motion during the processes. Be mindful of its size and weight. Dropping the freezer is likely to damage it.

4.2 – Set-up

1. Before switching on electrical power to the freezer, make all desired external connections:
 - A. AC power connection
 - B. External alarm
2. Turn on the AC switch. If the DC power option has been provided please see the supplemental instructions.
3. **Notice:** Ensure the access port stopper or sealant is in place. Remove factory tape at the port stopper prior to initial use.
4. After the freezer reaches its operating temperature and its door is opened and closed, the partial vacuum created when warm air is admitted, then cooled, will prevent reopening of the door until the pressure is equalized. A vacuum relief port is provided to accelerate this process.
5. Be mindful of any electrical shock hazards associated with making electrical connections to the freezer, especially the external alarm connection.
6. **Notice:** To activate the battery for the alarm system, please place the battery switch to the "on" position. Battery switch is located in the main power housing on the rear of the freezer.

5. Operation

5.1 – Operation of the SU105UE freezer comprises four stages:

1. Monitoring temperature performance using the Graphical User Interface (GUI) touch screen control panel.
2. Managing the freezer contents.
3. Cleaning and defrosting the freezer.
4. Calibrating the freezer's display RTD.

Specification of responsibilities for each of the above components of freezer operation should be part of the procedures and policy documents and guidelines for the clinical, laboratory, or other activity for which the freezer is used. Safety requirements are integral to these responsibilities.

5.1.1 – Graphical User Interface (GUI) & PIN

A Password Identification Number (PIN) may be set, but is not displayed. The default PIN is 1234 and may be changed by the user to any four-digit numeric. Use the PIN to control access to parameter change screens.

The GUI is preprogrammed with generic default values for most parameters listed on page nine, so entering the date, time and temperature setpoint are the most essential actions. Unless temperature limits are set manually, the software calculates default values appropriate for the temperature setpoint.

The GUI uses a menu system to display and modify system values. Generally, each screen displays certain values and contains “soft” buttons that are pressed to access other screens (according to the menu structure), and each screen has a soft button to return to the Home screen and a “Back” soft button to return to the next higher level of the menu (from which it was called).



5.1.2 – GUI Menu

The GUI menu tree below starts with the Home screen. (How to get there is described later.) Soft buttons provide navigation to the screens on the next level of the menu tree.

Home – display current freezer temperature.

- **Setup** – display Password Identification Number (PIN) status, door defrost status, temperature setpoint, system date and time and alarm status.
- **Setup** – display temperature setpoint.

Change Setpoint – display and change the temperature setpoint and high and low temperature limits.

Alarm Setup – display and change the Temp. Delay (to delay an over temperature alarm after a door opening), Audible Delay (time interval to silence the audible alarm upon request), Ext. Delay (to delay remote alarm contact closure after alarm condition is detected) and Door Delay (period that the door may remain open without alarm).

Date & Time Setup – display and change system date and time.

Door Defrost – enable/disable automatic door defrosting and/or set a manual defrost time and initiate manual defrost.

PIN Setup – disable/enable the system PIN and change the PIN.

- **Silence Alarm** – temporarily silence audible alarm.
- **Event Log** – tracks the last approximately 200 alarm conditions such as door openings, temperature setpoint changes, over temperature condition, and power outages.
- **Chart History** – display the cabinet interior air temperature over the last 24 or 48 hours, or 7 days.
- **About** – display freezer model number, serial number, firmware version, engine number, run hours, temperature setpoint, and install date.
 - **Service** – display cabinet, control and cold-head RTD temperatures, warm-head thermistor temperature and engine voltage, current and power.

Diagnostics – display temperature setpoint, engine running power as a percentage of maximum running power, and freezer condition status.

Service Contact – provides phone, email, and web address for manufacturer.

RTD Calibration – display RTD readings and calibration offsets to apply to reading (used to compensate for discrepancies between Display RTD and user-supplied temperature standards).

- **Firmware Upgrade** – display screen for firmware check and upgrade options.
- **Alarm Test** – Tests alarm.

5.1.3 – Basic GUI Controls

- Generally, to change a value on a screen, Tap the appropriate soft button to highlight the parameter.
- Use the +/- buttons to enter the desired value and then use the “Save” soft button to complete the change.
- PINs are entered through a numeric keypad screen with an “Enter” soft button to complete the entry and an “Exit” soft button to terminate it.
- PINs may be disabled on the **PIN Setup** screen by leaving the new PIN value blank.
When the PIN is disabled, any person can perform all actions available via the GUI, including silencing alarms and calibrating the RTDs.
- The following examples of GUI usage describe sequential button taps, e.g., 1 > 2 means: tap button labeled “1” then tap button labeled “2”. GUI display screens are named and those names are shown in bold. Access to certain screens requires entry of the system PIN via a numeric keypad screen; this entry is shown as the PIN button tap.

Guide to Basic GUI Functions

ON / OFF	Switch the main power on, located at the back of the unit above the AC cord.
Battery Power	Switch on the battery power located on the left of the Recessed Electrical Panel. This is essential if monitoring is required in the event of a power failure.
Change Setpoint	Tap Home > Setup > Setup > Enter PIN > Enter > Change > Setpoint > +/- > Save
Silence Alarm	Tap Home > Setup > Silence
Event Log	Tap Home > Setup > Event Log > Prev. Page, Next Page
Chart History	Tap Home > Setup > Chart History

Guide to Advanced GUI Functions

Alarm Setup	Tap Home > Setup > Setup > Enter PIN > Enter > Alarms > xxx Delay > +/- > Save
Date and Time	Tap Home > Setup > PIN > Date & Time > +/- > Save
Change PIN	Tap Home > Setup > Setup > Enter PIN > Enter > PIN > Enter New PIN > Enter > Re-enter New PIN > Enter
Calibrate RTDs	Tap Home > Setup > About > Service > RTD Calibr. > RTD Select > +/- > Calib.

5.1.4 – GUI Instructions



1. Start Screen:

Turn On Freezer and Battery Power

- Stirling Ultracold splash screen will appear for 3 seconds



2. Home Screen:

The Home screen will be displayed next

- Tap the **Setup** button to proceed to system settings



3. Data Setup: From the Setup Screen

- Tap the **Set-up** button to change alarm settings, date & time, door defrost heater, and PIN
- Tap the **Silence** button to temporarily silence the audible alarm
- Tap the **Event Log** button to track the last approximately 200 events
- Tap the **Chart History** button to track the box air temperature over the last 12 hours, 24 hours or 7 days
- Tap the **About** button for freezer information including build and service and calibration
- Tap the **Back** button to return to the Setup Screen
- Tap the **Home** button to take you back to the Home Screen

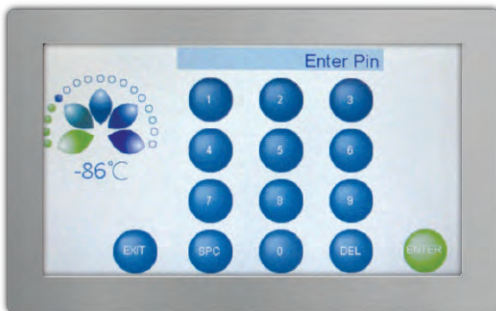

4. PIN Number: By default, Silence and Calibration require PIN

- Tap **1 2 3 4**
- Tap **Enter**



5. Secure Temperature Setpoint: To observe the current temperature setpoint

- Tap **Change** to change the temperature setpoint and over / under temperature thresholds
- Tap the **Alarms** button to change the alarm delays
- Tap the **Date & Time** button to change system date and time
- Tap the **Door Defrost** button to setup auto defrost or to start a manual defrost
- Tap **PIN** to change or disable PIN
- Tap the **Back** button to return to the Setup Screen
- Tap the **Home** button to take you back to the Home Screen



6. Alarm Setpoint: To change the setpoint or over/under temperature thresholds

- Select the appropriate parameter then use the + and – buttons to adjust then tap **Save**
(Note: If Save is not tapped new values will not be used)
- Tap the **Back** button to return to the Setup Screen
- Tap the **Home** button to take you back to the Home Screen



7. Alarm Delay: From the Setup Alarms Screen

- Select the appropriate parameter then use the + and – buttons to adjust then tap **Save** (Note: If Save is not tapped new values will not be used)
- **Temp. Delay** delays an over temp alarm after a door opening
- **Audible Delay** delays beeper for a period of time when silence is tapped
- **Ext. Delay** delay between audible alarm and remote alarm
- **Door Delay** period of time that the door can be open before sounding an alarm
- Tap the **Save** button to save configurations
- Tap the **Back** button to return to the Setup Screen
- Tap the **Home** button to take you back to the Home Screen



8. Date and Time: To setup the date and time select

- **Change Time** – use the <, >, +, - buttons to set the time then tap **Save**
- **Change Date** – use the <, >, +, - buttons to set the date then tap **Save**
- Tap the **Back** button to return to the Setup Screen
- Tap the **Home** button to take you back to the Home Screen



9. Door Defrost Heater:

When set to Auto Defrost, the door defrost heater will cycle 15 minutes ON and 20 minutes OFF unless otherwise programmed

- Auto Defrost parameters are not adjustable
- To enable Manual Defrost tap the **Auto Manual** button to activate Manual mode
- Set Manual Defrost for any value up to 30 minutes
- Tap **Enter**
- When the desired cycle is completed the system will revert to the Auto Defrost Mode



10. Change PIN:

By default the PIN is enabled. Use the PIN setup to change or disable the PIN

- To change the PIN use the keypad to enter a new 4 digit PIN then tap **Enter**. You will then be prompted to reenter the new PIN then tap **Enter**
- To disable PIN leave the Enter New PIN field blank and tap **Enter**



11. Event Log:

The Event Log will display the last approximately 200* events in about 30 pages, listing 7 events per page. The last 7 events are shown by default. Events beyond 30 pages will not be saved

- Tap **Prev Page** and **Next Page** to scroll through the pages
- Tap the **Back** button to return to the Setup Screen
- Tap the **Home** button to take you back to the Home Screen

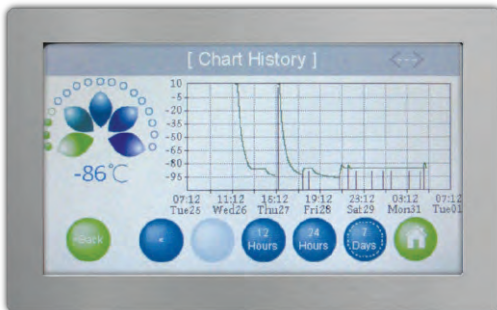

12. Chart History:

Chart History will display the internal box air temperature for the last 12 or 24 hours, or 7 days

- Tap the **Back** button to return to the Setup Screen
- Tap the **Home** button to take you back to the Home Screen

* Approximate because the length of the stored parameter changes depending on the event. Once the registers are full, the oldest data is rejected to make place for the newest data.

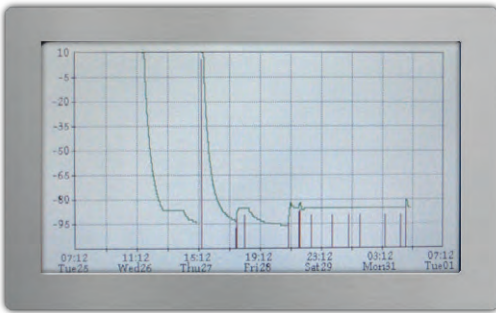

13. Chart History, Zoom: The Chart History can be enlarged to use the entire display

- Tap the screen to enlarge or reduce the Chart History Screen



14. About Freezer: To observe specific freezer information including Model and Serial Number, Firmware Version, Engine Number, Run Hours, Setpoint, and Date

- Tap the **Service** button to look at freezer parameters such as temperatures and engine voltage, current, and power
- Tap the **Back** button to return to the Setup Screen
- Tap the **Home** button to take you back to the Home Screen



15. Performance Snapshot:

The Service Screen gives you access to system information and calibration, as well as Firmware Upgrade options, Alarm Tests, Diagnostics, Service Contact, and RTD Calibration

- Tap the **Firmw. Upgrade** button to for system firmware upgrades
- Tap the **Alarm Test** button to test temperature alarms
- Tap the **Diag.** button to get to the system diagnostics screen
- Tap the **SVC Contact** button find dealer information
- Tap the **RTD Calibr.** button to calibrate the RTD (Note: PIN required to calibrate the RTD)
- Tap the **Back** button to return to the Setup Screen
- Tap the **Home** button to take you back to the Home Screen



16. Alarm Test:

Alarm Test Screen provides alarm testing

- Tap the **Firmw. Upgrade** button to for system firmware upgrades
- Tap the **Alarm Test** button to test temperature alarms
- Tap the **Alarm Test** button again to stop beeping



17. Diagnostics:

Diagnostic Screen provides system health information

- Tap the **Back** button to return to the Setup Screen
- Tap the **Home** button to take you back to the Home Screen



18. Service Contact:

Service Contact Screen provides phone, email, and web address for manufacturer

- Tap the **Back** button to return to the Setup Screen
- Tap the **Home** button to take you back to the Home Screen





19. Calibration:

RTD Calibration Screen is used to compensate for discrepancies between the Display RTD and a user provided standard

- Tap **RTD Select** until the desired RTD is selected then use the + and – buttons to adjust the offset. Tap the **Calib.** button to save changes
- Tap the **Back** button to return to the Setup Screen
- Tap the **Home** button to take you back to the Home Screen

5.2 – Managing Freezer Contents

The SU105UE freezer is designed for long-term storage of sample materials with ultra-low, well-regulated temperature storage requirements. Many times these materials are collected in cassettes or other carriers for ease of inventory and transportation. Such carriers have respective safety requirements and best practices for usage that become part of the requirements for managing freezer contents.

- The temperature setpoint for the freezer should be changed as appropriate for the materials being stored using the GUI as described above, as may the high and low temperature limits, as necessary.
- The current freezer temperature is displayed on the Home control panel screen, and a temperature history chart is available on the control panel screen.
- Materials may be placed in the freezer in any convenient arrangement that does not block the access port, interfere with the door gasket, or prevent the door from closing completely.
- The Safety Precautions section of this Operating Manual is especially pertinent to this component of SU105UE freezer operation, as ultra-low temperatures are encountered directly. The user is directed to review those Safety Precautions.

5.3 – Cleaning

Cleaning the Freezer Surfaces

- Clean the exterior surfaces of the SU105UE cabinet as needed by using a soft cloth and mild detergent. Do not use solvent (such as bleach) or harsh abrasive cleansers or pads.
- When appropriate, remove ice that accumulates inside the freezer by defrosting it.
 - Transfer the contents of the freezer to alternate storage, switch off the power to the freezer and wait for the ice to melt.
 - Wipe up moisture with a clean cloth. If the freezer door can be left ajar safely, defrosting will be more rapid.
 - After defrosting the freezer, switch the power back on. When the temperature reaches the setpoint, return the contents to the freezer.
- Note the Safety Precautions section of this Operating Manual while defrosting the freezer.

5.4 – Calibration of the RTDs

The SU105UE Display RTD and Control RTD may be calibrated by inserting a temperature sensor through the access port of the cabinet wall and securing it next to the RTDs located in the right rear corner of the interior just above the shelf.

- To provide access to the RTDs, it may be necessary to transfer the contents of the freezer to alternate storage. Note the Safety Precautions section of this Operating Manual while making such transfers.
- Navigate to the RTD Calibration screen using the GUI.
- To calibrate:
 - Use the “RTD Select” soft button to highlight the RTD reading on the screen.
 - Use the “+” and “-” soft buttons to adjust the offset to the desired value.
 - Tap the “Calib” soft button to save changes.

6. Transporting, Moving and Storage

To move the freezer to another location or temporarily place it into storage, perform the following steps:

- Transfer the contents of the freezer to alternate storage. Note the Safety Precautions section of this Operating Manual while making such transfers.
- Shut down the freezer by turning off the power and allowing it to come to room temperature.
- Dry the inside of the freezer compartment and clean any spills.
- Disconnect wires and cable connected to the freezer. See Section 4.2 for precautions associated with this task.
- Disinfect with suitable sterilizing agent if the freezer has been used for biohazards. Do not use bleach.
- Close and secure the door to the freezer.
- Move the freezer. See Section 4.1 for precautions associated with this task.

7. Specifications

7.1 – Freezer Specifications

Electric Power	100V - 240V (±10%) at 50 to 60Hz
Maximum Power (Current)	300 watts (3 amps @120V, 1.5 amps @240V)
Electric Supply Rating	15 amp or greater grounded circuit
Cooling System / Device	Direct cooling by a free-piston Stirling engine and thermosiphon heat transfer
Refrigerant, Engine	Helium
Refrigerant, Thermosiphon	R-170 (Ethane) 30-33 grams <i>To be repaired only by trained service personnel. Component parts shall be replaced with like components.</i> <i>Risk of fire or explosion. Flammable refrigerant used. Do not drill or puncture inner liner.</i> <i>Consult Repair Manual/Owner's Guide before attempting to service this product. All safety precautions must be followed.</i> <i>Dispose of properly in accordance with federal or local regulations. Follow handling instructions carefully.</i>
Temperature Range	-86°C to -20°C @ 32°C (90°F) ambient, adjustable in 1°C increments
Ambient Operating Temperature	5°C to 35°C (41°F to 95°F)
Warehouse Storage Temperature	-5°C to +60°C (at RH 65%)
Operational Environment	This ultra-low temperature freezer is designed for use in a normal laboratory environment. Avoid unusual dust or particles circulated through the rejection heat exchanger.
Useful Life	12 years
Volume	105 liters (3.7 cu.ft.)
Interior Dimensions (H x D x W)	533 x 432 x 457 mm (21 x 17 x 18 in)
Exterior Dimensions (H x D x W)	864 x 711 x 686 mm (34 x 28 x 27 in)
Net Weight, Empty	100 kg (220 lbs.)
Insulation	High performance vacuum insulated panels and polyurethane foam using the Ecomate® environmentally friendly, SNAP-compliant blowing agent
Noise	Advanced noise abatement, <48 dB(A) at 1 meter
Current Fuse	No fuse is used. Maximum current is below 3 Amps at 120 Volts. No surge current occurs at start and stop.



Control Sensor	Two RTDs (PT100 Class A)
Dry Contacts	Normally closed, normally open, common; activated by power outage or any alarm condition
Battery Back-up	12 hour control battery back-up for touchscreen (6V Lead Acid Battery)
Pull-Down from 25°C Ambient	9 hours to -80°C (empty cabinet)
Recovery from Door Opening (ENERGY STAR® Final Test Method)	40 minutes to -80°C
Warm-Up Profile	2 hours to -60°C at -80°C (empty cabinet) 5.2 hours to -40°C at -80°C (empty cabinet)
Steady State Energy Use	<4 kWh/day at -80°C
Heat Dissipation	563 BTU/h (load to HVAC) at -80°C (empty cabinet)

7.2 – Materials Specifications

Part	Material	Color	Treatment
Body: Main Body, Door, Front Cover and Top Cover	Mild steel	White	Powder coated
Interior	Steel	White	Powder coated
Shelf	Stainless Steel (non-adjustable)	-	-
Handle	Aluminum	Gray	Powder coated
Hinges	Steel	White	Powder coated
LCD Bezel	Polycarbonate	Gray	Natural

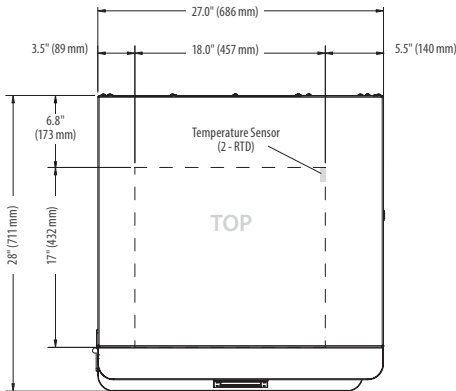
**NOTICE:**

When stacking freezers remove rear casters and replace with adjustable leveling feet.

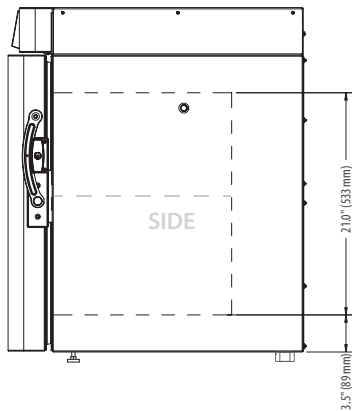
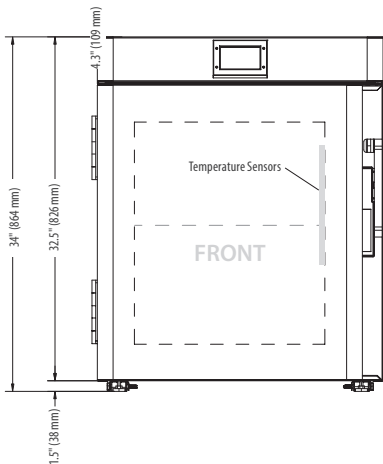

8. Troubleshooting

Problem	Possible Cause	Solution
Freezer does not power on	Power is not getting to the freezer from the Power Supply	Check the connections to the power supply Assure that the wall plug is firmly seated
	Inadequate air circulation	Remove airflow obstructions
Freezer does not achieve desired temperature	Inadequate power	Assure that the wall plug is firmly seated
	Improper environment	Remove freezer from direct sunlight, hot room, etc. Check that freezer is level. Tilts of more than 12 degrees in some directions will degrade performance.
Freezer cools slowly	Door is not completely closed	Check for ice buildup, remove if necessary, and properly close door
	Door is open and closed too often	Minimize opening and closing of door
	Inadequate air circulation	Unblock air vents

Note

This freezer is designed for storage of frozen product.
For best results:

- Always operate your freezer at full capacity with real or simulated product to increase the thermal mass, displace air and maintain optimal stability.
- Always minimize the frequency and duration of door openings.

9. Warranty



The following Warranty applies to the SU105UE manufactured by Global Cooling, Inc. In order to maintain maximum uptime and to optimize customer service, Global Cooling, Inc. reserves the right to exchange the SU105UE with a serviceable new or previously used replacement at its discretion.

Limited Warranty, USA

- The warranty period starts **TWO WEEKS** after the original date of shipment from Global Cooling, Inc.
- The Stirling Ultracold freezer is warranted for a period of **TWO YEARS** for materials and labor.
- The Stirling Ultracold free-piston Stirling engine and thermosiphon is warranted for a full **SEVEN YEARS**, parts only.
- If a service issue arises, contact Global Cooling, Inc. Service Department to register Warranty Service and initiate a resolution.
- Advanced authorization for a service company to diagnose the problem must be approved by Global Cooling, Inc.
- Global Cooling, Inc. will not be responsible for charges incurred for service calls made by a third party prior to authorization by Global Cooling, Inc.
- Global Cooling, Inc. retains the right to replace any product in lieu of servicing it in the field.
- Liability in all events is limited to the purchase value only.
- Under no circumstances will Global Cooling, Inc. be responsible or held liable for consequential or incidental damages associated with loss of stored product in the event of an equipment failure.
- Extended warranty programs are available. Contact Global Cooling, Inc. for a custom warranty solution.

Limited Warranty, CANADA

- The warranty period starts **ONE MONTH** after the original date of shipment from Global Cooling, Inc.
- The Stirling Ultracold freezer is warranted for a period of **TWO YEARS** for materials and labor.
- The Stirling Ultracold free-piston Stirling engine and thermosiphon is warranted for a full **SEVEN YEARS**, parts only.
- If a service issue arises, contact Global Cooling, Inc. Service Department to register Warranty Service and initiate a resolution.



- Advanced authorization for a service company to diagnose the problem must be approved by Global Cooling, Inc.
- Global Cooling, Inc. will not be responsible for charges incurred for service calls made by a third party prior to authorization by Global Cooling, Inc.
- Global Cooling, Inc. retains the right to replace any product in lieu of servicing it in the field.
- Under no circumstances will Global Cooling, Inc. be responsible or held liable for consequential or incidental damages associated with loss of stored product in the event of an equipment failure.
- Extended warranty programs are available. Contact Global Cooling, Inc. for a custom warranty solution.

International Distributor Limited Warranty

- Global Cooling warrants that Distributor shall acquire products purchased hereunder free and clear of all liens and encumbrances.
- Global Cooling further warrants all products to be free from defects in materials under normal use and service for a period of **TWO YEARS**.
- The Stirling Ultracold free-piston Stirling engine and thermosiphon is warranted for a full **SEVEN YEARS**, parts only.
- Warranty will start **ONE MONTH** after the ship date from Global Cooling.
- Global Cooling shall provide to Distributor, without charge, replacement parts to substitute for parts that must be replaced by reason of valid warranty claims.
- This warranty obligation is limited solely to the replacement of replaceable defective parts.
- All service charges with respect to the repair or replacement of defective parts of products shall be the responsibility of the Distributor and/or Distributor's customer.
- Distributor, on behalf of Global Cooling, shall perform such ordinary and customary servicing, repair and/or parts replacement within the Territory at Distributor's expense; which may be passed on to Distributor's customer, at Distributor's discretion.

10. CE Documentation

EC DECLARATION OF CONFORMITY

MANUFACTURER

Business name: Global Cooling Inc.
 Full address: 6000, Poston Road
 Postal code: 45701
 Place: Ohio, Athens
 Country: United States of America

EUROPEAN OFFICE

Which is established in the European Community and has access to the full or part of the Technical File
 Business name: Global Cooling B.V (GCBV)
 Full address: Lage Dijk 22
 Postal code: 5705 BZ
 Place: Helmond
 Country: The Netherlands

DESCRIPTION AND IDENTIFICATION OF THE MACHINERY

Generic denomination: Ultra low temperature freezer
 Function: Long term storage of ultra-low temperature of pharmaceuticals, biologicals, cell cultures, serum and other materials which require stable temperatures in the range of -86 to -20 degrees Celsius.
 Model: SU-105U
 Type: Ultra low temperature freezer
 Serial number: -
 Commercial name: Stirling Ultracold

COMPLIANCE

The manufacturer declares that the above mentioned machinery fulfills all relevant provisions of

Machine Directive (2006/42/EC)	EMC Directive (2004/108/EC)
Low Voltage Directive (2006/95/EC)	Pressure Equipment Directive (97/23/EC)

In conjunction with the following harmonised standards and where appropriate other technical standards and specifications

for the risk assessment

NEN-EN-ISO 14121-1:2007/C1:2007; NPR/ISO-TR 14121-2:2008;

for the design and manufacture

NEN-EN-ISO 12100:2008;
 NEN-EN-IEC 60204-1:2006/A1:2009; NEN-EN 349:1994+A1:2008;
 NEN-EN-IEC 61310-1:2008; NEN-EN-ISO 3744:2009; NEN-EN 55022:2006/A1:2007;
 NEN-EN-IEC 61326-3-1:2008/C1:2008; NEN-EN-IEC 61010-1:2001/C11:2002;
 NEN-EN 378-1:2008+A1:2010

The technical and legal experts of Consultants Europe BV in Weesp, has determined the conformity of the above unit, with applicable Directives and standards

Place: Helmond

Identity: Mr. David M. Berchowitz

Date: 24 August 2011

Signature: 

THIS PAGE INTENTIONALLY LEFT BLANK



6000 Poston Road, Athens, Ohio 45701, USA
t: 740.274.7900 / 855.274.7900 f: 740.274.7901 www.stirlingultracold.com

©2019 Stirling Ultracold, Global Cooling, Inc. All Rights Reserved.
Global Cooling technology is manufactured under U.S. and International patents. Stirling Ultracold is a trademark of Global Cooling, Inc.
Specifications subject to change without notice. Refer to www.stirlingultracold.com for the latest specifications.

