

VWR® 401L CO2 Stackable Incubator Shaker

Instruction Manual



Version: 1

Issued: 2023-2-16

CE



Note

Please read this manual carefully before installing the equipment. Please follow all the instructions contained in this manual during operation. Otherwise, the user shall be responsible for any consequences arising therefrom, including potential bodily harm and/or property damage.

Copyright:

1. No part of this manual may be reproduced, distributed, or transmitted in any form or by any means, including photocopying, recording, or other electronic or mechanical methods, without the prior written permission of the publisher, VWR International.
2. Contents contained in this manual, including all technical data, specification, and performance figures, are subject to change without notice.

Preface

Thank you for choosing the VWR 401L CO₂ Stackable Incubator Shaker. Your trust and support are greatly appreciated.

Our Incubator Shaker Series is designed for shaking and heating samples with optional CO₂ and humidity control to meet the research and experiment needs in modern biotechnology. Our state-of-the-art embedded microprocessor system utilized in this machine has powerful data processing ability, outstanding stability, excellent interference resistance, and high precision control of the temperature and shaking performance of the instrument. Sophisticated manufacturing processes, aesthetic product design, and a user-friendly interface are elegantly incorporated into the production of the instrument.

The VWR 401L Incubator Shaker is widely used in biology, microbiology, medicine, pharmaceuticals, food science, and environmental science, which include various biological and chemical reactions that require high precision control of temperature and shaking. Applicable processes include bacteria culture, fermentation, and hybridization, and enzyme and cell tissue research. It is also applicable to both static and dynamic culture of microbial cells and strains.

Table of Contents

1. Unpacking Guide	P1
2. Overview	P3
3. Preparation	P9
4. Safety Instructions	P13
5. Installation	P14
6. Structure	P18
7. Control Panel	P19
8. Settings	P20
9. Operational Instructions	P31
10. Maintenance	P32
11. Troubleshooting	P33
12. Optional Accessories	P35
13. Warranty	P38

Unpacking Procedures

1. Lift the instrument with a lift or forklift and place the instrument on a level surface with caution.
2. Remove the protective packing material and inspect if the instrument is damaged.
3. Locate the packing list inside the user manual on page 2.
4. Check the packing list in the manual to make sure there are no missing accessories; if there are please contact VWR immediately.

Warning

- Due to its weight, please use a lift or a forklift or other lifting apparatus to transport or move the instrument. **DO NOT TRANSPORT OR MOVE THE INSTRUMENT WITHOUT HELPERS.**
- Inspect contents upon receiving the instrument, if the instrument is upside down, contact the manufacturer immediately.
- Make sure the power is disconnected and the instrument is not loaded when moving the instrument. Please move instrument individually before stacking them.

Packing List

Name		Qty	Remark
401L CO2 Stackable Incubator Shaker		1	
Accessories	Power Cord	1	
	Liquid Collection Tray	1	
	Fuse	1	AC250V/15A
	#2 Philips Screwdriver	1	
	24mm Open-End Wrench	1	Platform handle backup
	S10 Wrench	1	
	User Manual	1	
	CO2 Inlet Filter	1	Equipped in type of CO2 Model only
	Filter Protection Package	1	Equipped in type of CO2 Model only
	CO2 Inlet Tube Clip	4	Equipped in type of CO2 Model only
	PU Pipe (5 m)	1	Equipped in type of CO2 Model only
	Silicone Tube Φ 12x2	1m	
	T-Connectors Φ 14mm	1	
	Two-way Connectors Φ 14mm	1	

2.1 Description

The VWR 401L CO₂ Incubator Shaker with controlled temperature, shaking, humidity, and CO₂ concentration can be stacked three units high, while occupying the floor space of only one unit. The combination and innovation of Proportional-Integral-Derivative (PID) and Fuzzy control technology have allowed for high precision control of the instrument's chamber temperature. The three axis eccentric balance mechanism is stable, reliable, and durable. The speed control system has a speed terminal feedback system, which ensures high precision oscillation within the instrument. An inverter compressor is used for refrigeration, thus making cooling a highly efficient process with low energy consumption. The instrument's noise reduction design keeps the noise level to below 55dB. The independent modular operation design makes it easy to selectively choose which functions to run, so it can be used as a CO₂ incubator for culturing cells statically, or as an ordinary open air shaker, or as a biochemical incubator.

This machine can run continuously, but also includes a timer which can be set up to 999 hours. 12 segment functions can be programmed to achieve diverse environment conditions, and specific running times for each segment can be set to create the necessary environments. The rail platform makes it convenient to place and retrieve samples in the instrument. The 401L Incubator Shaker features a large capacity chamber, with the capability of holding fifteen 3L Erlenmeyer flasks. The 10-inch color touch screen provides easy and streamlined operation. Additionally, the WiFi monitoring system can be set up with multiple phones, allowing multiple users to remotely monitor the same instrument. Remote monitoring also sends timely alarm information to deal with emergency situations quickly and safely, without air intake to protect cultured cells.

2.2 Features

- Good thermal insulation, air tightness and waterproof properties: The main chamber, door, and insulation materials of the instrument all use foamed polyurethane materials, which have the advantages of lightness, sound insulation, shockproof, electrical insulation, heat resistance, cold resistance, solvent resistance, and aging resistance.
- Automatic adjustment of PID control: Instrument adjusts itself to the appropriate parameters according to the different user set conditions and ensures high precision and stability of temperature.
- Strong cooling capacity: Chamber can be cooled to 18°C below the ambient temperature (Lowest temp is 4 °C).
- Excellent temperature control performance: When stable at 37°C, the uniformity in the cavity reaches $\leq \pm 0.3^\circ\text{C}$.
- Pull out rail platform: Operator can easily pull the platform out to load or unload fixtures and then push it back and lock. Only one locking handle in the middle of the platform provides fast and convenient operation.
- Intuitive visual 10 inch color touch screen: Modular display shows the different functions. 10 inch screen provides large display to see and control parameters.
- Capacitive touch screen: The capacitive screen is durable and has no reaction delay when the screen is pressed.
- Simple screen interface: A variety of functions, set values, and actual values are displayed. At a glance, the user will know all the running parameters as they are easy to find and operate.
- The display screen has an automatic lock screen, automatic sleep function, and password protection functions: Prevents mis-operation or allowing non-authorized personnel to perform non-permissible operations.
- Three units can be stacked: Instrument can be purchased as a single unit, double stack, or triple stack with the option to stack units (up to triple stack) in the future.
- Bi-directional ultraviolet sterilization: The chamber is equipped with two sets of UV sterilization light components to enhance the germicidal effect and reach every part of the chamber.
- Inverter compressor: Noiseless, durable, highly efficient, and energy saving.
- Ultra quiet design: The whole instrument runs very quietly; the noise level is less than 55dB, giving the operator a quiet environment.
- Slow acceleration and deceleration: Shaking function starts and stops slowly to prevent large shear forces on the bacteria or cells.
- High pressure water rinse for the platform and bottom of the chamber: Simple cleaning that is fast and efficient.

2. Overview

- Automatic defrosting function: The machine automatically defrosts according to its own needs, no need to enter the prescribed time or any other sets.
- Energy saving control: The advanced Polyurethane material foaming process improves the insulation performance, reduces energy consumption, and saves more electrical energy.
- DC brushless motor drive: Low noise, high efficiency, no maintenance, long life, minimal heat, no effect on the chamber temperature.
- Double cross flow fan driving air circulation: High wind pressure, large air volume, low noise, low heating capacity and long life.
- 12 automatic programmable sections control function: User can set 12 different speeds, temperatures, and times at which to automatically run the instrument.
- Acousto-optic alarm and protection functions: Over temperature alarm, over speed alarm, sensor fault alarm, timing alarm, open door alarm, over CO2 concentration alarm, over humidity alarm, electric leakage protection, no intake alarm (Instrument with CO2 function)
- Open door protection: When the door opens, the machine stops running to protect the safety of the operator.
- Automatic recovery run: When the operation stops as a result of power failure, after the power is supplied again, the instrument automatically resumes operation according to the original parameters of operation.
- Long timing: User can set 0-999 hours and 59 minutes of operation time, the touch screen displays the remaining time, and when time runs up the instrument prompts "Program Finish".
- Powerful data storage function: Data can be stored for more than 2 years. Data is recorded in 1 minute intervals.
- Real-time data query function: On the display, operator can query the running data from the latest 7 days. Data is recorded in 1 minute intervals.
- USB data export function: With a USB port, it is easy to export more than 2 years of running data records to the USB.
- Alarm information recording and query function: Alarm information memory is stored and can be queried.
- Display has a real-time temperature curve display function: Historical data and real-time data is displayed on the same diagram display and is easy to check.
- Display can be switched from English interface to Chinese interface: If user prefers the Chinese interface, it is easy to switch at any time.
- A remote WiFi monitor accessory: Instrument can be remotely controlled through wireless LAN monitoring or internet mobile phone. Many mobile phones can monitor the same instrument.
- Computer monitoring software accessory: Instrument can be monitored by a LAN wired computer monitoring, and can remotely send alarm messages to connected mobile phones.

More on the instrument version with CO2 functions:

- CO2 infrared sensor: Accurate control, sensitive response, stable performance and long life. It is not affected by any changes in temperature or humidity. Matches the full set of CO2 control accessories.
- Multi High-Efficiency-Particulate-Air (HEPA) filters: Prevent gas impurities in the cylinder or pollution source from contaminating the gas in the chamber.
- Easy cleaning inner chamber: It is easy to wipe and disinfect the inner chamber without dismantling the platform to minimize the growth of bacteria.
- Double hollow glass window: Heating and antifogging design allow the cell culture in the chamber to be clearly seen.
- High humidity anti rust and anti condensation design: Prevents the door from rusting due to high humidity. Prevents rust in the internal chamber. Prevents the micro flow of water on the door to the ground when the door is open.
- Active humidification device: The humidity in the chamber can be controlled.

The CO2 control function unit with RH Controller:

In order to ensure the stability of the humidity in the cavity, recommended that flasks be arranged evenly and that circulation, ventilation be ensured in the cavity.

The specific layout method and the number of flasks are as follows:

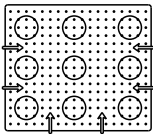
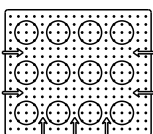
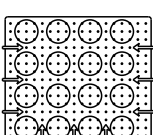
Set RH Value	Max. QTY of the Flask	Place	Test conditions
70%	9		Take 250ml flask as an example: 1. Fill 250ml flask with 100ml pure water 2. Set the temperature of the instrument: 37 3. Set the speed of the instrument: 125rpm 4. Ambient temperature: 20 ~25
80%	12		
90%	16		

2.3 Specifications

Model	76628-472/ 76628-470/ 76628-474/ 76628-498	76628-492/ 76628-490/ 76628-494/ 76628-496	76628-478/ 76628-476/ 76628-480/ 76628-482	76628-486/ 76628-484/ 76628-488/ 76628-468
Temp. Range	Room Temp. Minus 18°C~60°C (Lowest Temp. is 4°C)			
Temp. Accuracy	±0.1°C			
Temp. Uniformity	±0.4°C (@37°C)			
Speed	0 (Stop), 30~300rpm			
Speed Accuracy	±1rpm			
Orbit Diameter	φ 25 mm		φ 50mm	
CO ₂ Sensor	NA	IR	NA	IR
CO ₂ Control Range	NA	0~20%	NA	0~20%
CO ₂ Control Accuracy	NA	±0.1%	NA	±0.1%
Recover Time on the Temp. Close Door	NA	5min.	NA	5min.
Recover Time on the CO ₂ Close Door	NA	5min.	NA	5min.
Max. Humidity	95%			
Illumination	Both of Side Lamps			
Disinfection	Both of Side UV Lamps			
Display	10" Color Capacitance Touch Screen			
Max. Capacity	Clamp Capacity: 50ml×135/ 100ml×60/ 150ml×60/ 200ml×60/ 250ml×60/ 500ml×34/ 1000ml×22/ 2000ml×15/ 3000ml×12/ 5000ml (Thomson)×6 Sticky Mat: 50ml×187/ 100ml×112/ 150ml×104/ 200ml×84/ 250ml× 77/ 500ml×40/ 1000ml×28/ 2000ml×15/ 3000ml×15/ 5000ml (Thomson)×8			
Max. Load	20Kg			
Platform Dimensions	900×560mm			
Timer	0-999Hours59min.			
Internal Dimensions	1005×690×350mm			
Automatical Defrost	Yes			
Internal Working Height	340mm			

2.3 Specifications

Model	76628-472/ 76628-470/ 76628-474/ 76628-498	76628-492/ 76628-490/ 76628-494/ 76628-496	76628-478/ 76628-476/ 76628-480/ 76628-482	76628-486/ 76628-484/ 76628-488/ 76628-468
Door Open Direction	Downward*			
Outside Dimensions	1400×972×680mm**			
Net Weight	290Kg***			
Heat Power	<800W			
Cool Power	70~180W			

*Models 76628-498 / 76628-496 / 76628-482 / 76628-468 have Upswing Door on top unit

**Dimensions of Upswing Door unit are 1400×972×730mm

***Weight of Upswing Door unit is 295kg

Model	Power Supply	Power
76628-472/ 76628-470/ 76628-474/ 76628-498	AC110V±11V, 60Hz	180~950W
76628-478/ 76628-476/ 76628-480/ 76628-482		
76628-492/ 76628-490/ 76628-494/ 76628-496		180~1000W
76628-486/ 76628-484/ 76628-488/ 76628-468		

3.1 Placement Conditions

The instrument must be placed on a firm and level surface. The total weight of the instrument when fully loaded must be taken into consideration. There must be at least 20cm between the instrument and any wall or adjacent instrument.

Warning

- Pay attention to avoid any risk of bodily injuries from disassembling, lifting or moving the instrument.
- The CO₂ concentration may increase and can be harmful to your health if operating the instrument in a small and airtight room.
- Please keep the room ventilated when the CO₂ function is on. Additionally, please avoid direct inhalation of the gas when opening the door.
- Keep the vent of the instrument away from heat source or other vents, otherwise the compressor cannot be started or started frequently during refrigeration.
- When the instruments are stacked, make sure the floor loading capacity is at least 1.5 times the instruments weight. Stack them up against the wall or on the floor with a reinforced beam to ensure stable floor loading.

3.2 Ambient Conditions

- a. For indoor use only
- b. Ambient Temperature: 10°C-35°C
- c. Ambient Relative Humidity: 20%-80% RH
- d. Atmospheric Pressure: 10.88psi-15.37psi (75kPa-106kPa)
- e. Use a dedicated AC 110V power outlet with a capacity no less than 1.3 kW
- f. Power supply voltage fluctuation is less than 10% of rated voltage ($\pm 11V$ fluctuation for 110V outlet)

3.3 Dimensions

- Triple Stacked Unit with Downswing Top Door:

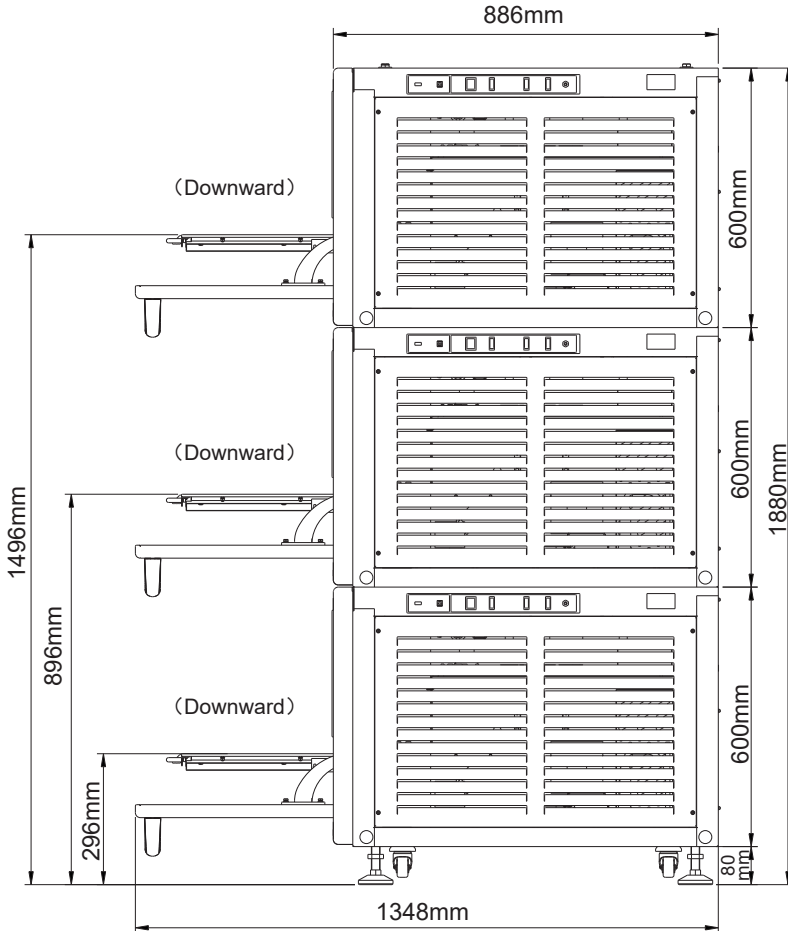

3. Preparation

- Triple Stacked Unit with Upswing Top Door:

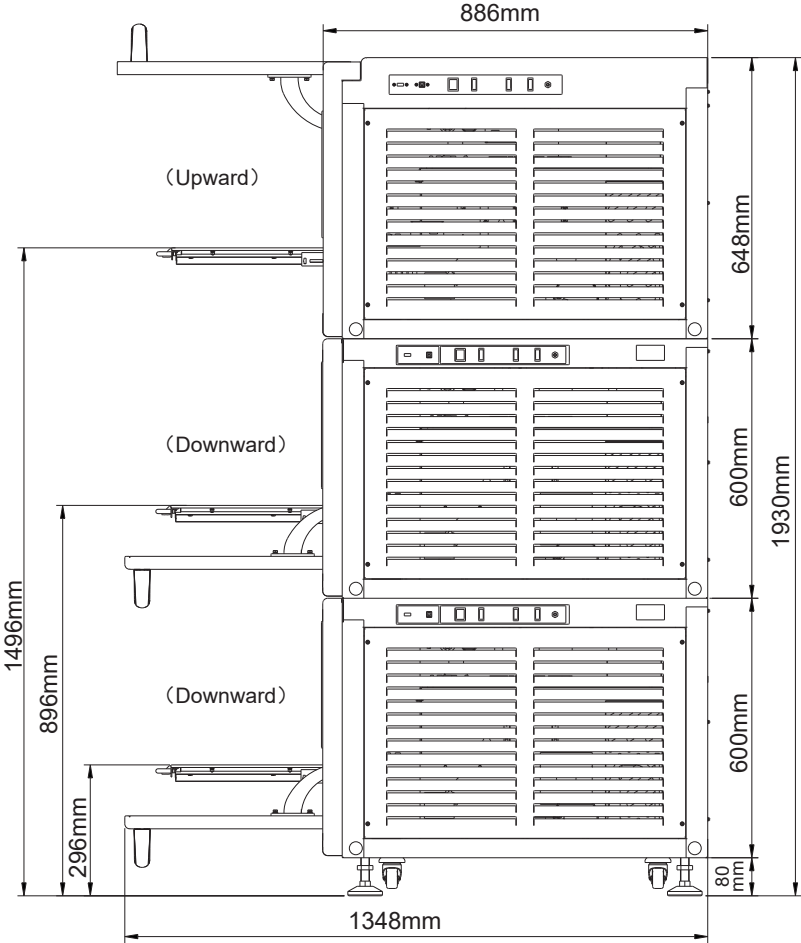

• Double Stacked Unit + 76628-568 Stand:

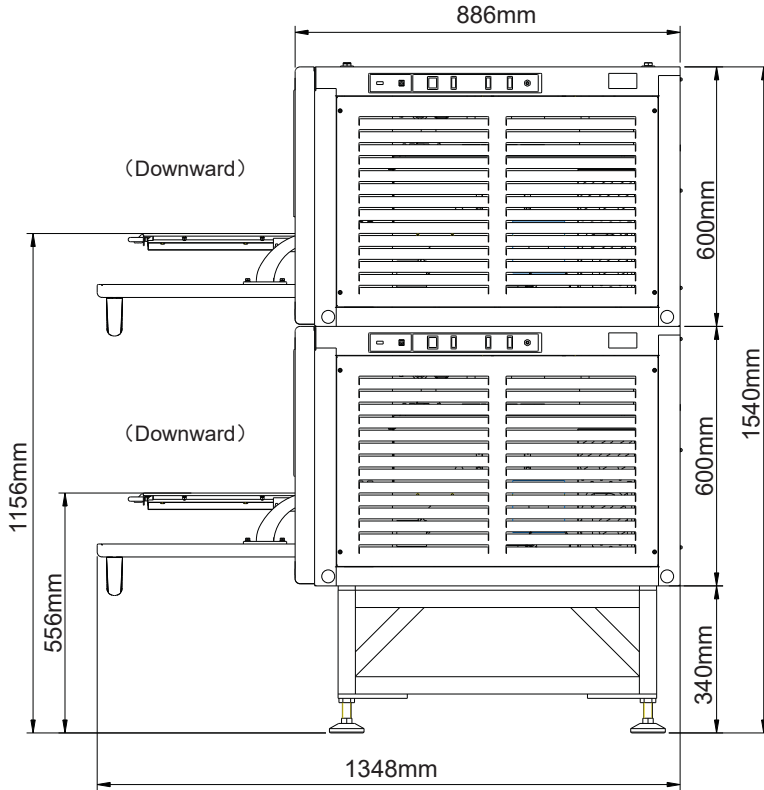

4. Safety Instructions



Please make sure to follow the safety instructions

- Please use a lift or a forklift or other lifting apparatus to raise or move the instrument.
- Make sure the power supply voltage matches the voltage of the instrument before it is connected.
- The instrument must be properly placed.
- Use a grounded power socket.
- Do not drag the power cord when unplugging.
- Do not use a damaged or non-designated power cord.
- Only qualified personnel are allowed to open the control box.
- Keep the handle on the platform screwed when the instrument is running.
- Keep the room ventilated.

Disconnect the power supply in any of the situations below:

- Moving or transporting the instrument
- Opening the power box
- Changing the fuse
- The malfunctions of instrument
- Equipment out of use for long term



: This instrument contains flammable refrigerant. Be careful when installing and operating to prevent the risks of combustion or explosion.



: Risk of burns may be created when operating or maintaining.



: Risk of hand injuries due to improper operation or accidents when opening the door.

Note

Lifting the instrument by hand should be prohibited. Please use a lift or a forklift or other lifting apparatus to raise or move the instrument.

5.1 Tools Requirement

- S10 Hex wrench, #2 Philips screwdriver, 24 Single open-end wrench
- A lift or forklift or other lifting apparatus with the minimum loading capacity of 772lb (350 kg)

5.2 Installation

- Ensure the installation site meet the requirement as instructed in Chapter 3.1.
- First floor instrument installation: Raise adjustable feet away from the ground,
- Slowly and smoothly move the instrument on its wheels to its designated location
- Loosen the four adjustable feet with a wrench to touch the ground, keep it level, then tighten the four adjustable feet with a wrench. The instrument should be stable and unable to be moved.

Adjust the height of feet to allow the instrument to move or be set:

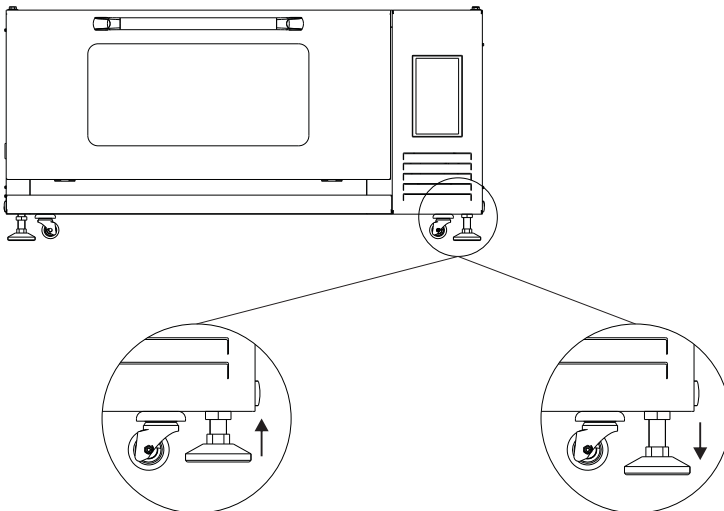

Adjust all feet up to off the ground, the instrument can move on the wheels.

Adjust the feet down to the ground so the instrument will be securely placed.

5. Installation

d. To stack a 2nd or 3rd unit, fix it with the four screws on both sides.

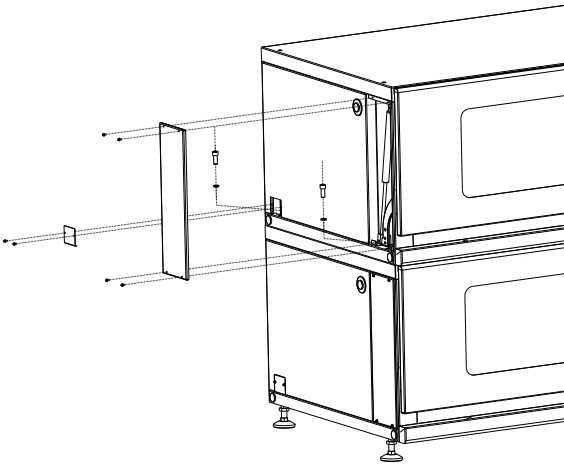
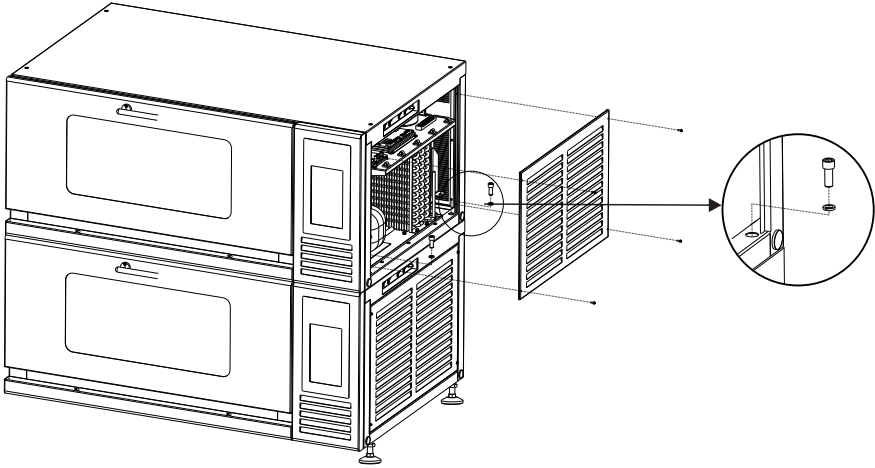

Note

Please make sure each instrument is placed level, stable, and still. Do not exceed the maximum load of 20 kg. The recommended maximum stacked shaker speed is 250 RPM for the second and third units.

5.3 Drain connection

- a. When stacked up to 3 units, units will need a Two-way Connector and 2 T-connectors.
- b. When stacked up to 2 units, units will need a Two-way Connector and a T-connector.

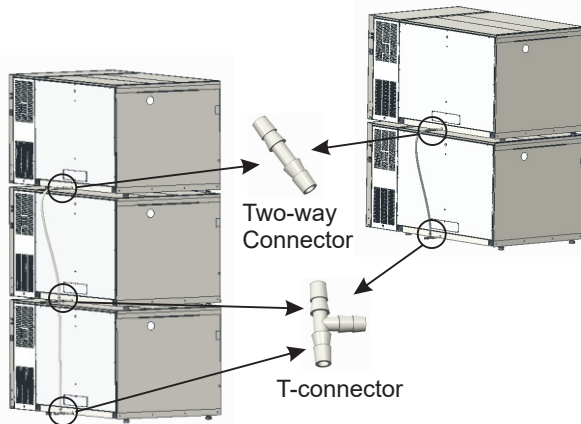

5.4 CO₂ Connection

1. Install a regulator with flow control valve onto the CO₂ Cylinder. Please use a regulator with a primary preset pressure of 25MPa (250kg/cm², 3500l b/in²), and a secondary preset pressure of 0.6MPa (2.0kg/cm, 30psiG).
2. Using the polyurethane tube provide connect the regulator to a CO₂ inlet HEPA filter first, and then to the CO₂ inlet located on the right side of the shaker. (See Figure 1)

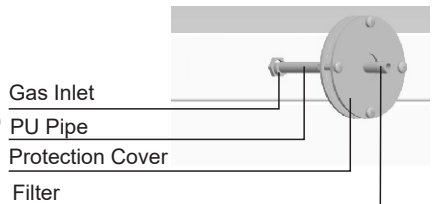

3. Set the CO₂ secondary flow control valve to 0.08~ 0.1M (11.6~14.5psi).

(WARNING: Excessive pressure may cause disconnection of internal pipes inside the CO₂ incubator which will result in leakage of CO₂ gas into the surrounding environment. High CO₂ concentration can cause harm to your health and may cause asphyxia or death. Maintenance is required if the inline tube falls off.)

Figure 1



Figure 2

5. Installation

A. Schematic diagram

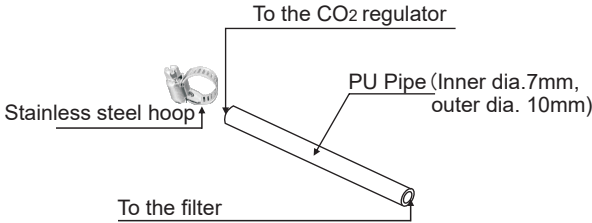

B. Actual picture

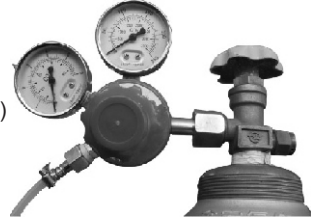

Note:

1. Do not move the pressure adjustment rod on the regulator when changing the CO₂ cylinder. It will affect the secondary pressure and will result in needing to reset the valve. The inline tube might fall off if the pressure is too high and maintenance will be required.
2. Check tube regularly to ensure it is safely connected. Change the tube if it is damaged or aged.
3. Use the stainless steel hoop to tighten the connection point of the Polyurethane tube and the filter to prevent the pipe from falling off and leaking gas.
4. Use more than 99.99% pure CO₂. Low purity may cause blocking of the filter or damage of the solenoid valve.



Warnings

- Make sure the gas supply meets the specified requirements.
- Make sure all the pipes are properly connected.
- Make sure the gas pressure settings are correct.
- Wrong pipe connection or pressure settings may cause CO₂ leakage.
- High CO₂ concentration will do harm to your health and may cause suffocation or death.
- Alternative methods should be taken if there is no sufficient ventilation in the room to guarantee safety. These methods include gas monitoring and alarming system.
- Maintaining correct gas pressures can prevent gas leakage.

• Downswing Door

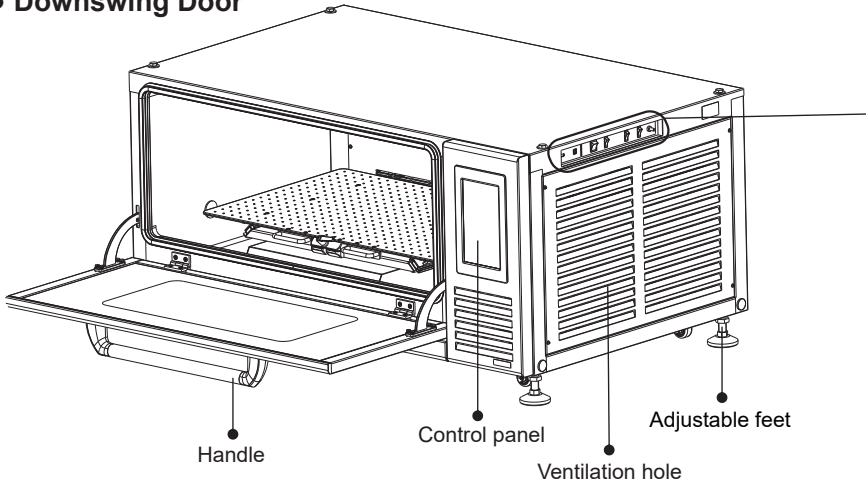

• Upswing Door

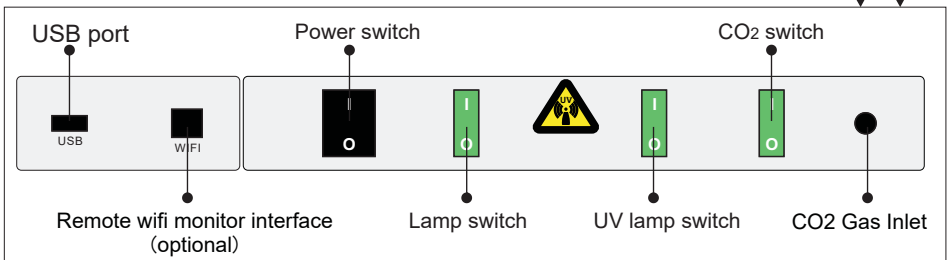
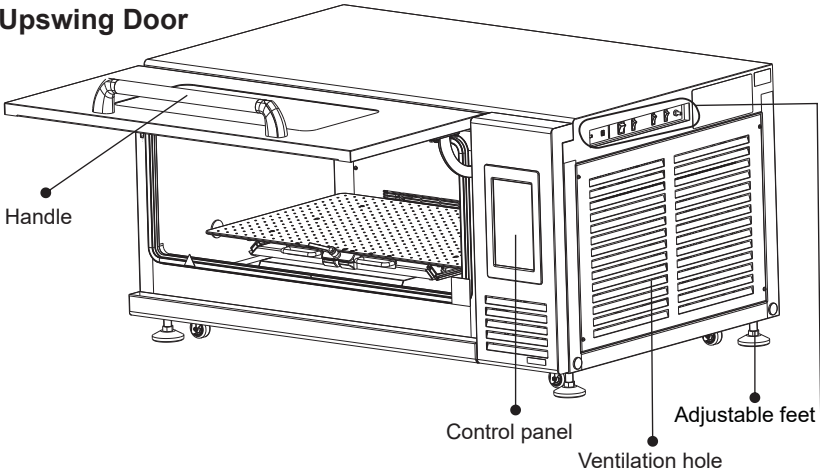

Main interface, e.g.:

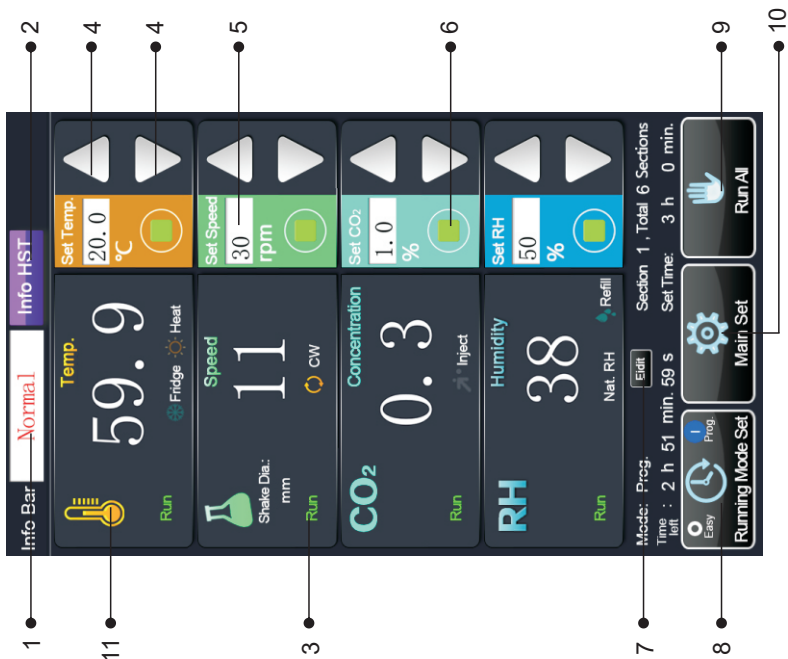

1. Displays the current operating status of the instrument.
2. Leads to the alarm information and history.
3. Displays the current function running status: either running, stop, or alarm.
4. Plus and Minus buttons: used to adjust the corresponding parameter.
5. Displays the set value: user can manually input a set value here.
6. Run / Stop button: runs the corresponding function when clicked.
7. Edit button for programmable mode: Sets up to 12 running segments.
8. Running mode button: Switches between "easy" and "program control" mode.
9. Run/stop all button: Runs and stops all functions.
10. Main settings button: Enters settings page (shown on page 20) then to corresponding settings page where user can edit settings.
11. Function icon buttons: Tap to display the real-time function performance, moving the blue line sets the function's parameter, the red line activates after one hour of operation to show the real-time temperature changes, the green line shows the current parameter performance.

This section will show all the main settings and how to use them. After confirming that the instrument is installed correctly, turn on the power switch of the instrument. The display shows the function parameter that was last set and saved.

Note: During the operation of the instrument, the password needs to be input before some functions are modified. The default password is “88888888”.

8.1 Easy Operation

1. Select “Easy” in “Running Mode Set” and enter “Easy Mode” interface.

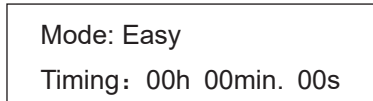

2. Click "Main Set" to enter the following interface, shown in Figure 3.
3. Select the relevant functions one by one, click to input the password to access the setting interface, click save, and then back.
4. All functions should show “stop” and “▶”
5. Click “Run All”, or click each “▶” to run individually; the function display changes to “Run” and “■”.
6. To stop the running all functions, click “Stop All”, or to stop running individual functions, button, press “■”.

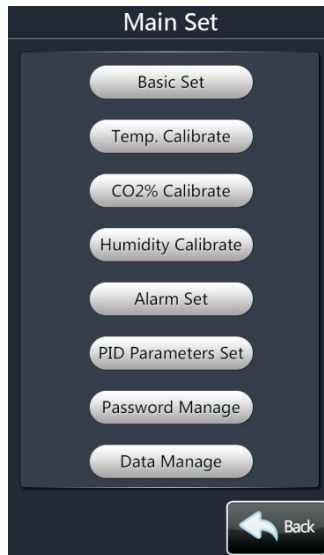

Figure 3: Main Set Interface

8.2 Program Mode Operation

1. Select "Program Control" in "Running Mode Setting" and press "Edit" to enter the "Program Control Mode" interface.

Mode: Prog.	<input type="button" value="Edit"/>	Section 1, Total 12 Sections
Time left: 00h 00min. 00s		Set Time: 3h 10min.

2. 1 to 12 segments can be set in program control mode. To set the parameter values (temperature, speed, and time) click the value display window, input the parameter value, confirm, save, and return.

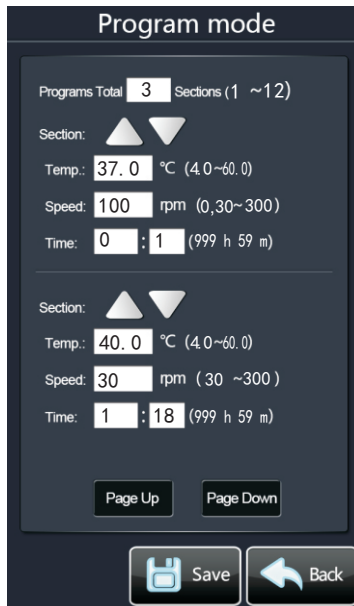

Figure 4: Program Control Mode

8. Settings

8.3 Instrument Settings

1. Click "Main set" to enter the interface shown in Figure 3 (page 20).
2. The following functions (a-h on the following pages) can be set by choosing the corresponding button, inputting the password, and entering the corresponding interface to input the relevant settings.
3. Click the corresponding button to input the desired parameter value, or click the corresponding "ON / OFF" to control the instrument-related function switch.
4. After setting, press "Save" and "back" or press "back" button to return to the instrument setting interface (Figure 3).
5. After setting the needed parameters and controls, click the "back" button under the "Main Set" page (Figure 3) to return the main interface to observe the running status of each function.

Note

1. After function parameters are set, press "Save" and then "Back", or just press "Back", and the instrument will run under the new parameters.

"Save" then "Back": If you press the "Save" button before returning to the Main Set page, the saved parameters will still exist and continue running if the instrument is powered off and back on.

"Back" only: If you do not press "Save" and only press "Back" to return to the Main Set page, the modified parameters will run while the instrument's power remains on. If the unit is turned off and back on, changes not saved will be discarded and reverted to the last parameters saved.

a: Basic Set





- 1. Lock LCD Time:** Sets the time in minutes of inactivity after which the LCD screen locks and the operator needs to input the password to unlock the instrument. Set the Lock LCD Time to "0" to keep the LCD screen unlocked.
Close LCD Time: Sets the time in minutes of inactivity after which the LCD screen closes into its energy saver state (screen off). Set the Close LCD Time to "0" to keep the LCD screen on.
- 2. Time Calibrate:** Sets the display time, the new time will show in the upper right corner of the main interface. Time is in 24-hour time.
- 3. Communication Address:** Input a value from 1 to 32 (the communication address is valid when multi-instrument networking).
- 4. Pause when door is open:** Set the status to "ON" to keep the instrument running when the door is opened; set the status to "OFF", to pause the instrument when the door is opened and the alarm "Open door and paused the unit" is displayed.

5. **Light turns on when door is open:** Set the status to "ON" to turn the light on when the door is open; set the status to "OFF" and the light will not turn on when the door is open.
6. **WIFI:** Turn on when connected to 76628-570 Remote Monitoring accessory
7. **Language choose:** Choose between English and Chinese for the display language

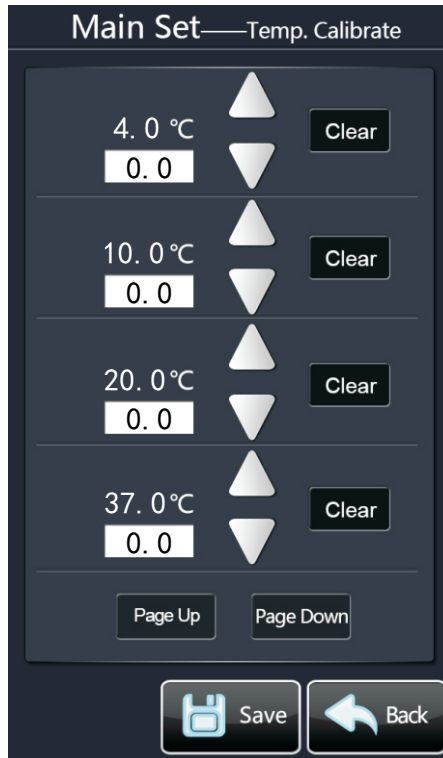
b: Temperature Calibration



Temperature can be calibrated by following the procedure below:

1. Set the instrument to the target temperature (start with 4°C)
2. Let instrument run and wait for the temperature to stabilize
3. Measure temperature inside chamber with thermometer
4. Input the difference between set temperature and actual temperature with  or 
5. Repeat steps 1-4 for 10°C, 20°C, and 37°C

c: CO2% Calibration



CO2 % Concentration can be calibrated by following the procedure below:

1. Set the instrument to the target Co2% (start with 1%)
2. Let instrument run and wait for the CO2% to stabilize
3. Measure CO2% inside chamber
4. Input the difference between set CO2% and actual CO2% with “▲” or “▼”
5. Repeat steps 1-4 for 3%, 5%, and 10%

d: Humidity Calibrate

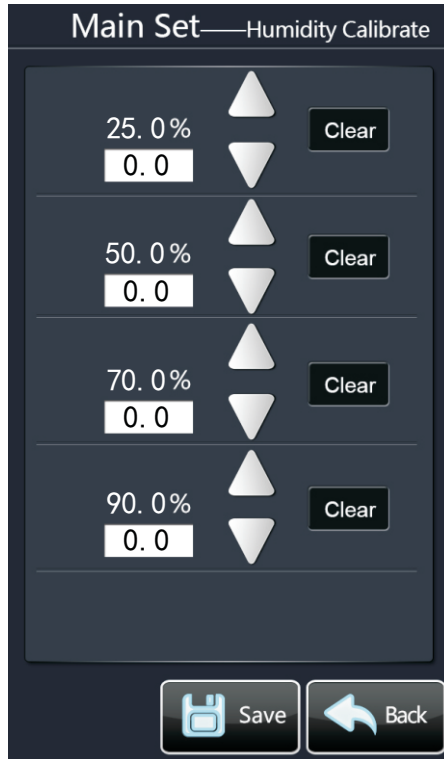

Humidity can be calibrated by following the procedure below:

1. Set the instrument to the target humidity % (start with 25%)
2. Let instrument run and wait for the humidity % to stabilize
3. Measure humidity % inside the chamber
4. Input the difference between the set humidity % and the actual humidity % using the "▲" or "▼" keys
5. Repeat steps 1-4 for 50%, 70% and 90% humidity

e: Alarm Set



For settings 1,2,4, and 6 the alarm is armed when the value is set and the status is “ON”. When the difference between the set parameter and actual parameter is larger than the absolute value of the alarm value, then the instrument will stop running and the function bar on the main interface will show the alarm information, and the info bar will show “Alarm”

The CO₂ % alarm is activated after 15 minutes of abnormal values

The “No Gas Alarm” activates when the instrument does not receive a CO₂ gas inject for over 5 minutes. The main interface will show alarm information.

When an abnormality occurs in the instrument, please refer to page 32 and page 33 for details.

f: PID Parameters Set

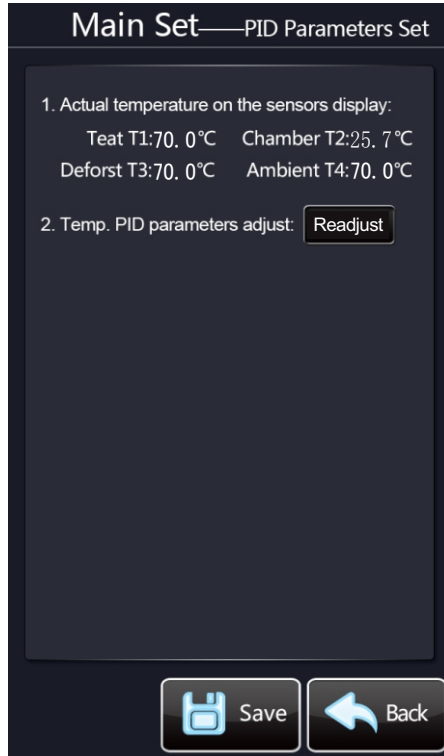

1. **Sensor** temperature for the instrument's display temperature does not need to be set, it displays the actual value.
2. **Readjust** the temperature control parameters: When the temperature control parameters appear abnormal through upper and lower irregular fluctuations, click the "Readjust" button. The following prompt interface appears, if a sensor readjustment is confirmed necessary then press "Yes". The instrument will automatically adjust its temperature control parameters.

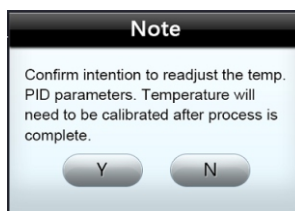

g. Password Manage (Main Set Password / Clear Data Password)

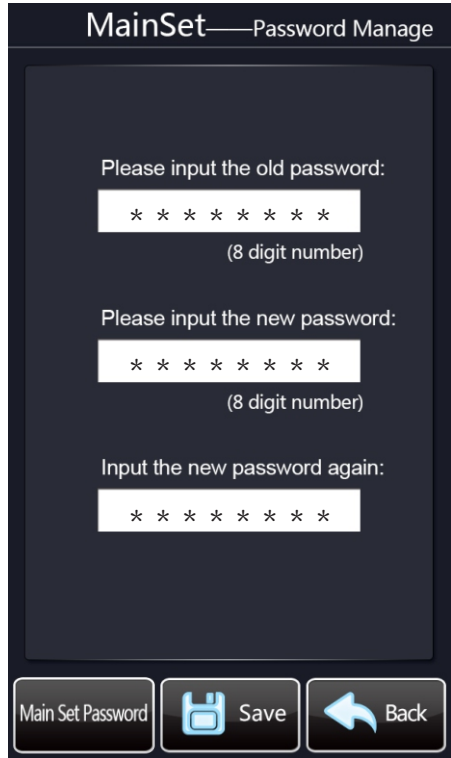

1. Input the old password - the initial password for the instrument is "88888888".
2. Input a new password and confirm the new password. The new password will be an 8 digit number.
3. Press save and back.
4. The new password is modified successfully.

h: Data Manage

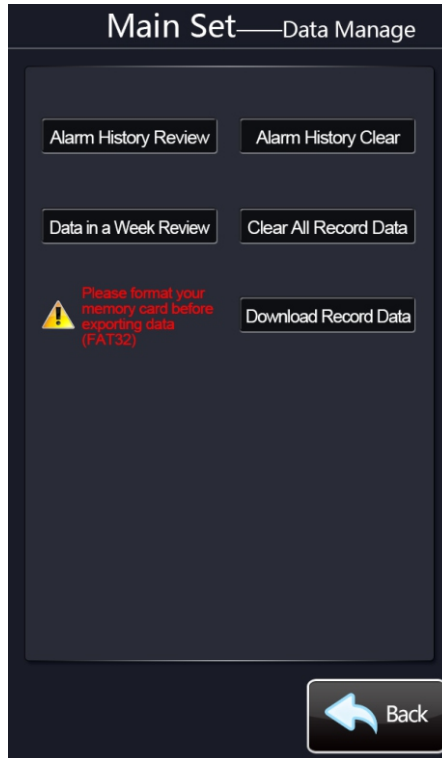

1. **Review Alarm History:** View all the historical alarm records automatically saved by the instrument.
2. **Clear Alarm History:** Clear all the historical alarm records saved by the instrument automatically.
3. **View Past Week's Data:** View the operation data of the instrument within the past week on the touchscreen. Running information includes time, temperature, speed, CO₂%, humidity and status (close: close door, open: open the door, stop: the instrument is not running).
4. **Clear All Record Data:** Clear all saved running data.
5. **Download Record Data:** Through the USB port on the instrument, all operation data recorded can be imported onto the USB, (the memory card should not exceed 4GB and the USB should be formatted to FAT32 in advance to delete the last saved files).

Instructions for Operation:

1. Only trained and professional personnel are allowed to operate the instrument
2. It is forbidden to put flammable and explosive reagents into the instrument, and the instrument can not be immersed in water.
3. Fully understand the nature of the chemical and the nature of the product created from any chemical reactions to avoid any accidents or damage on the instrument. When shaking volatile items, please do not close the door of instrument to prevent explosions, high pressure, liquid spray, or other dangerous actions.
4. Place the load symmetrical. Uneven or unbalanced sample loading can cause rocking of the instrument, creating a hazard.
5. When the heating or cooling is in use, make sure the sample does not affect the normal ventilation cycle inside the instrument.
6. Ensure the sample has been completely fixed before shaking, when restarting the instrument check whether the sample needs to be re-fixed. When abnormal noise is produced during shaking, reduce the speed or stop running, then re-fix the sample until the abnormality is eliminated.
7. Before running or stopping the instrument, confirm that the speed is set to minimum.
8. If the mechanical movement is unexpectedly interrupted then it may restart with no warning.
9. Wear suitable protective equipment when operating the instrument to prevent damage from liquid splashes, toxic or flammable gases exhausts.
10. After an unexpected interruption, set the operating temperature to ambient temperature to the maximum extent possible, avoid unnecessary burns, frostbite, or damage to the sample.
11. Do not block the vents to ensure smooth ventilation around the instrument.
12. When CO₂ is connected, ensure the instruments CO₂ connection port is tight and the seal has no leakage.
13. Do not switch on/off too frequently.
14. Reference this user manual for safety warning symbol explanations.
15. Please comply with the user manual when using the instrument, otherwise it may cause the instrument to malfunction or damage the instrument.
16. Please unplug before connecting water to the water inlet, do not flood the instrument.
17. High humidity can easily lead to decreased electrical insulation and the electrical current leakage risk increases; pay attention to electrical safety when operating under high humidity.
18. Please make sure the air circulation is sufficient when using CO₂. The CO₂% will increase in a small confined room and can harm the operator's health. Also, please avoid direct inhalation of the CO₂ gas when opening the incubator door.
19. No experiment samples are allowed in the electrical and mechanical inner workings; keep samples in the chamber.
20. Do not use excessive force when opening and closing the incubator door to prevent the instrument from being damaged.

21. Please reduce the frequency of opening the incubator door to help maintain constant temperature and save CO₂.
22. After the instrument's cooling function is used for 10 days continuously, a heating dehumidification process is recommended. Recommendation: heat the instrument to 45°C for half an hour.

Maintenance Instructions:

1. Do not let gasoline, oil, or any other volatile chemicals come into contact with the outside coating of the instrument.
2. No experiment samples are allowed in the instrument's inner workings.
3. Inspect the fastening screws on the flask clamp regularly to prevent them from dislodging.
4. Please clean the instrument regularly.
5. Do not clean the instrument with corrosive or flammable liquid and make sure these types of liquids are kept away from the instrument.
6. Please take off the side plates at the right and back side of the instrument to clean out dust on the condenser and fan to ensure good heat dissipation and high cooling efficiency.
7. Only use refrigerant that is consistent with what is noted on the nameplate (on left side wall) of the instrument, and do not fill excessively.
8. The power supply must be unplugged when machine is under maintenance.
9. Use the specified fuse and make sure to disconnect power when replacing the fuse.
10. Regularly check the screws of rotation parts and connected parts to ensure they are fastened and tight.
11. Regularly check the light source of the instrument
12. Regularly check the CO₂ gas inlet.
13. Please check if the v-belt at the bottom of the instrument is not loosened after using the instrument for 6-12 months. Press the middle part of the v-belt inward about 10mm. Please check the abrasion condition of the v-belt after using the instrument for 2 years and change the same type of v-belt (Z1092) if necessary.





Notice

- The refrigerant used in the instrument is flammable.
- Ensure good ventilation of the room.
- Do not use any mechanical means or other ways to accelerate the defrosting process.
- Do not use electrical appliances in the instrument except our company recommends.
- It is forbidden to smoke around the instrument, have an open flame or use electrical appliances that directly generate electrical sparks around the instrument
- When repairing the compressor or refrigeration related pipeline, please move the instrument to an open space, do not use laboratory site to maintain.



11. Troubleshooting



Troubleshooting			
Error		Cause	Solution
LCD Display	LCD		
Overspeed alarm	Display "alarm"	Speed difference more than 5 rpm	Contact local sales/service
		Electrical malfunction	Contact local sales/service
		Electric motor failure	Contact local sales/service
Over-temperature alarm	Display "alarm"	Temperature difference more than 3 degrees	Contact local sales/service
		Temperature sensor damaged	Change sensor
		Cooling system failure	Contact local sales/service
		Heating system malfunction	Contact local sales/service
Communication failure		Communication cable not connected	Connect communication cable
		Communication cable interrupted	Restart instrument
	Display "Open door pause"	Door open	Close incubator door
		Sensor damaged	Change sensor
No gas intake	Display "No Gas In"	Empty CO ₂ gas tank	Change CO ₂ gas tank

Note: When "No Gas In" alarm is activated the instrument will continue to attempt to inject CO₂ gas, when the gas supply is resumed, the alarm will be automatically cancelled.

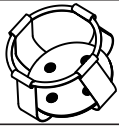
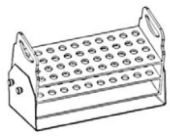
Instructions		
Display window off Platform not shaking	No power	Plug not connected
		Power outlet out of power
		Power switch off
Display window on but Platform not shaking	Burned fuse	Change to a new fuse with the same specification
		<div style="display: flex; justify-content: space-around;"> <div style="text-align: center;">  <p>Position: at the power outlet</p> </div> <div style="text-align: center;">  <p>Position: inside the electrical cabinet</p> </div> </div>
Platform shaking but the display window malfunctioning	High frequency interference source exists in the same power line	Press the confirm button to recover display
		Remove interference source of the same power line or use a dedicated power line
Display window on but platform not shaking	Poor contact of door switch	Contact local sales/service
High temperature fluctuation	Frequent door opening	Reduce times of door opening and decrease the time consumed when opening the door
Loud noise	Unleveled instrument	Adjust footings to level the instrument
	Loose platform	Fasten the fixing screws of the platform
	Loose flask clamp	Fasten the fixing screws of the flask clamp

12. Optional Accessories **VWR** | vwr.com

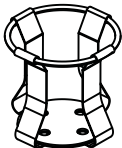
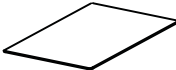
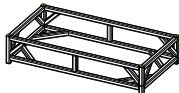
Model	Name	Specifications	Max Qty	Figure
76628-552	Flask Clamp	25mL	135	
76629-514		50mL	135	
76628-528		100mL	60	
76628-544		150mL	60	
76628-550		200mL	60	
76628-566		250mL	60	
76628-572		500mL	34	
76628-574		1000ml	22	
76628-578		2000mL	15	
76628-588		3000mL	15	
76628-502		Tube Rack	40 x Φ 14mm	
76628-506	40 x Φ 16mm		9	
76628-522	40 x Φ 18mm		9	
76628-524	27 x Φ 22mm		9	
76628-546	21 x Φ 30mm		9	
76628-516	Adjustable Tube Rack	40 x Φ 14mm	9	
76628-518		40 x Φ 16mm	9	
76628-530		40 x Φ 18mm	9	
76628-532		27 x Φ 22mm	9	
76628-534		21 x Φ 30mm	9	
76628-542		24 x Φ 30mm	6	
76628-508	96-well Microplate Holder		30	
76628-540	Fixture Separating Funnel		4	

Model	Name	Specifications	Max Qty	Figure
76628-580	Infusion Bottle Clamp	500ml	40	
76628-536	Infusion Bottle Clamp	1000ml	28	
76628-538	Self-Adhesive Silica Mat	140×140mm	24	
76628-528	Stand for 401L Stacking Incubator Shakers	1400×737×30mm	1	
76628-526	Multifunction Spring Platform	350×240×80mm	4	
76628-520		450×400×80mm	1	
76628-510		428×295×80mm	2	
76628-576	Visor to Block Ambient Light		1	

12. Optional Accessories **VWR** | vwr.com

12.1 How to use the Remote WiFi Monitor

1. Connect the 76628-570 monitor to the incubator shaker as shown below:

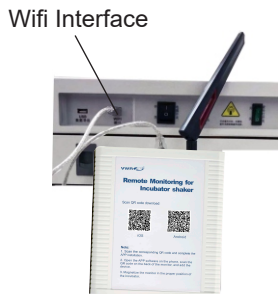

2. Connect the incubator shaker to WiFi by tapping the WiFi symbol at the top left of the main screen and entering the WiFi info.
3. Scan the iOS or Android QR code and complete the APP installation.
4. Open the APP software on the phone, scan the QR code on the back of the monitor, and add the device.
5. Place the monitor in the proper position by using the magnets on the back of the monitor.

Scan QR code download:



iOS



Android

WARRANTY CARD

Save this card carefully please. When you need service, contact the service company with card & invoice.

Warranty Card

User Name		Telephone	
Address			
Zip Code		E-mail	
Product Name		Model	
Serial number		Purchase Date	

- **Warranty Scope:**
 1. Warranty period is 24 Months from purchase date.

- **Warranty is not valid under the following circumstances:**
 1. Warranty term is expired.
 2. Damage due to improper use, maintenance or handling.
 3. Unmatched serial numbers, or modification of serial numbers.

Customer service hotline: please contact VWR's customer service department at 1-800-932-5000.
 User: the above information should be completed by the seller.

Service Record

To be completed by maintenance personnel during any service visits.

1	Maintenance company's name		Maintenance Date	
	Address		Tel	
	Maintenance documents No.		Maintenance personnel to sign	
2	Maintenance company's name		Maintenance Date	
	Address		Tel	
	Maintenance documents No.		Maintenance personnel to sign	
3	Maintenance company's name		Maintenance Date	
	Address		Tel	
	Maintenance documents No.		Maintenance personnel to sign	

