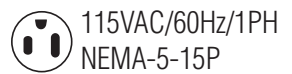
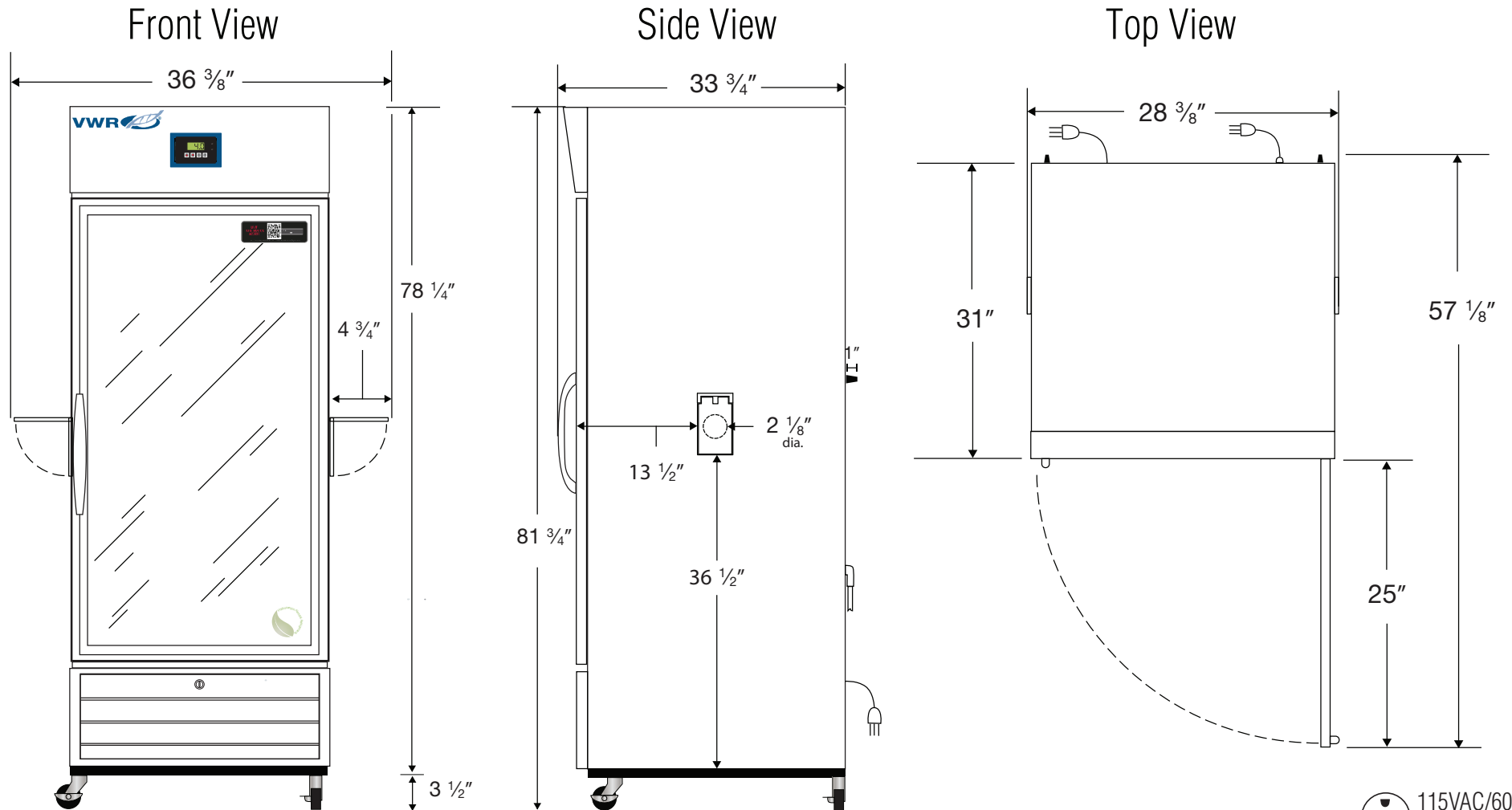

Exterior

Cat# 76514-300/VWR-HCCP-23

Cu.Ft.	Defrost	Door	Int Door	Shelves	W"	D"	H"	Refrigerant	H.P.	Amps	Weight
23	Cycle	1 Glass	0	4 Adj.	$28 \frac{3}{8}$	$34 \frac{3}{4}$	$81 \frac{3}{4}$	R290	$\frac{1}{5}$	3	296 lbs.