

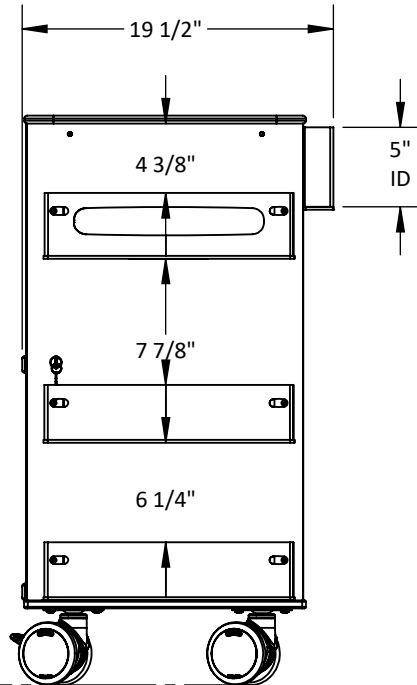

Drawer inside dimensions:
 W - 3.375"
 D - 15.45"
 H - 3.25"



<p>PROPRIETARY AND CONFIDENTIAL</p> <p>THE INFORMATION CONTAINED IN THIS DRAWING IS THE SOLE PROPERTY OF TRIPPNT. ANY REPRODUCTION IN PART OR AS A WHOLE WITHOUT THE WRITTEN PERMISSION OF TRIPPNT IS PROHIBITED.</p>			<p>DIMENSIONS ARE IN INCHES TOLERANCES: FRACTIONAL ± 1/8" ANGULAR: MACH ± BEND ± TWO PLACE DECIMAL ± THREE PLACE DECIMAL ±</p> <p>Outside dimensions rounded up to nearest 1/8"; inside dimensions rounded down to nearest 1/8"</p>	NAME	DATE	 <p>This document and the information contained therein are the property of TRIPPNT, Kansas City, Missouri. Recipient agrees NOT TO: (1) Use such information for purposes other than those expressly authorized by TRIPPNT. (2) Furnish such information to any other person in whole or in part for any purpose whatsoever without express written permission of TRIPPNT. (3) Reproduce or copy this document either in whole or in part without the express written permission of TRIPPNT.</p>	
				DRAWN	JH		11/23/20
				CHECKED			
				ENG APPR.			
				MFG APPR.			
				Q.A.			
				COMMENTS:			
	NEXT ASSY	USED ON	MATERIAL			SIZE	
			HDPE, ABS, PETG			DWG. NO.	
			FINISH			20 - 53370.1	
			Smooth, no rough edges			REV.	
	APPLICATION		DO NOT SCALE DRAWING			0	
						Weight: 65 lbs.	
						SHEET 1 OF 1	