

SPEAKMAN®

SE-1150

Optimus™ Pedestal Mounted Eye And Face Wash System

SPECIFICATION

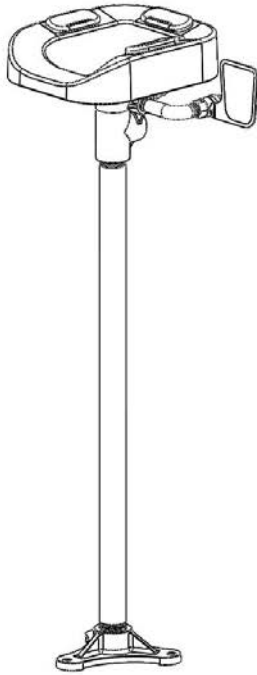

FEATURES:

- Independent eye wash & face wash integrated into one, multi-functioning safety unit
- Aerated sprays for eyewash comfort & innovative face pads for full face cleansing
- Flip top caps with integral flow controls
- Stainless Steel bowl
- ½ in. NPT female brass, chrome-plated, full flow stay-open ball valve
- Stainless steel push handle activator
- ½ in. NPT female inlet
- 1 ¼ in. NPT female waste
- 4.9 gpm @ 30 psi
- 1 ¼ in. IPS galvanized steel piping pedestal
- DuraJade™ powder coated finish on pedestal for durability & enhanced corrosion resistance
- Patent Pending
- Universal Emergency Sign Included

COMPLIANCE:

- Certified to ANSI Z358.1

OPTIONS:

ADD SUFFIX TO MODEL #

- | | |
|--------------------------------|-------------------------------|
| • Anti-freeze protection valve | <input type="checkbox"/> -FPV |
| • Hand & foot operation | <input type="checkbox"/> -HFO |
| • Hand-held spray | <input type="checkbox"/> -HS |
| • In-line strainer | <input type="checkbox"/> -ILS |
| • P-trap | <input type="checkbox"/> -PT |
| • Scald protection valve | <input type="checkbox"/> -SPV |

WARRANTY:

- 3 year limited

SEE REVERSE FOR ROUGH-IN DIMENSIONS

THIS SPACE FOR ARCHITECT/ENGINEER APPROVAL.

SPEAKMAN®

400 ANCHOR MILL ROAD | NEW CASTLE, DE 19720
P: 800-537-2107 | F: 800-977-2747
WWW.SPEAKMANCOMPANY.COM

REVISION DATE: JANUARY 2014



Management Systems
Registered to ISO 9001

587

SPEAKMAN®

Optimus™ Pedestal Mounted Eye And Face Wash System SE-1150

SPECIFICATION

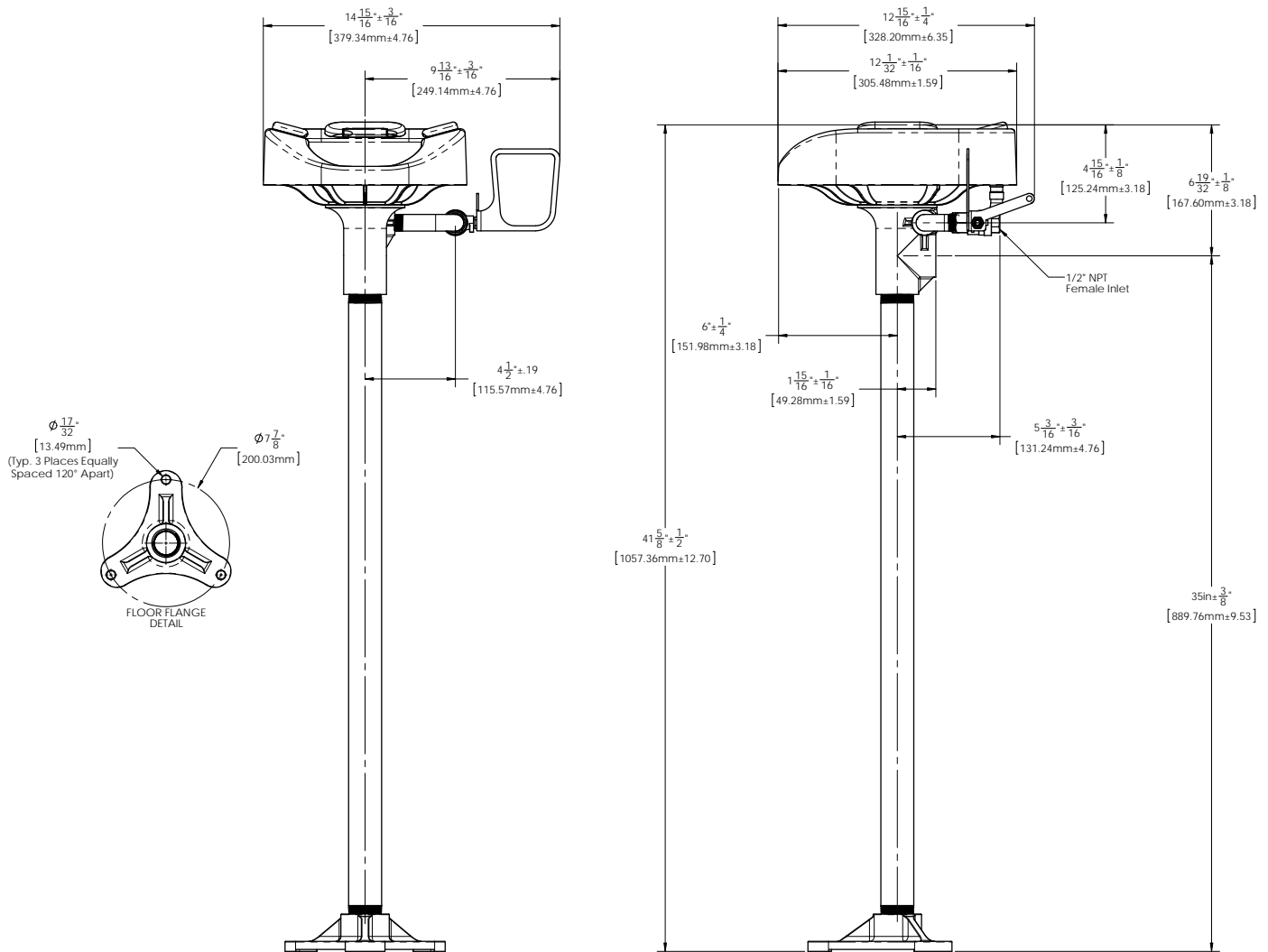

NOTE: 1. All dimensions are in inches (millimeters) unless otherwise specified and are subject to change without notice.

THIS SPACE FOR ARCHITECT/ENGINEER APPROVAL.

SPEAKMAN®

400 ANCHOR MILL ROAD | NEW CASTLE, DE 19720
 P: 800-537-2107 | F: 800-977-2747
 WWW.SPEAKMANCOMPANY.COM

REVISION DATE: JANUARY 2014



Management Systems
 Registered to ISO 9001