

SPECIFICATIONS (continued)

	I/P® 73	I/P® 82
Maximum intermittent discharge pressure—psi (bar):	40 (2.7)*	20 (1.4)*
Maximum vacuum:	610 mm (24) in Hg*	508 mm (20) in Hg*
Maximum suction lift:	7.3 m (24 ft) H ₂ O*	7.0 m (23 ft) H ₂ O*
Number of rollers:	3	
Occlusion:	Standard fixed	
Maximum pump speed (rpm):	650	
Nominal torque load:	13 kg-cm (180 oz-in)	
Housing materials:	Polycarbonate (PC) or Polyphenylene sulfide (PPS)	
Roller/rotor materials:	Plated cold-rolled steel (CRS) or Stainless steel (SS)	
Operating temperature† (ambient):	0 to 40°C (32 to 104°F)	
Noise level:	<70dBa @ 1 meter	
Compliance (for CE mark):	EN809 (EU Machinery Directive)	

* Testing with NORPRENE®, PHARMED® BPT and TYGON® tubing. Values will be less with silicone and C-FLEX®.

† Use in this temperature range for continuous duty operation with no decrease in performance or product life.
Pump Heads will work outside this range with some possible reductions in performance or product life.

WARRANTY

Use only MASTERFLEX precision tubing with MASTERFLEX pumps to ensure optimum performance. Use of other tubing may void applicable warranties.

The Manufacturer warrants this product to be free from significant deviations from published specifications. If repair or adjustment is necessary within the warranty period, the problem will be corrected at no charge if it is not due to misuse or abuse on your part, as determined by the Manufacturer. Repair costs outside the warranty period, or those resulting from product misuse or abuse, may be invoiced to you.

The warranty period for this product is 2 years from the date of purchase.

PRODUCT RETURN

To limit charges and delays, contact the seller or Manufacturer for authorization and shipping instructions before returning the product, either within or outside of the warranty period. When returning the product, please state the reason for the return. For your protection, pack the product carefully and insure it against possible damage or loss. Any damages resulting from improper packaging are your responsibility.

TECHNICAL ASSISTANCE

If you have any questions about the use of this product, contact the Manufacturer or authorized seller.

MASTERFLEX®

(US & Canada only) Toll Free 1-800-MASTERFLEX • 1-800-637-3739
(Outside US & Canada) 1-847-381-7050

masterflex.tech@avantorsciences.com • www.avantorsciences.com/masterflex

*EN809 manufactured by:

Masterflex LLC.

28092 W Commercial Avenue
Barrington, IL 60010

OPERATING MANUAL

MASTERFLEX® **I/P**®

**FOR ALL I/P STANDARD
PUMP HEAD MODELS**

A-1299-0019
Edition 16

MASTERFLEX®

(US & Canada only) Toll Free 1-800-MASTERFLEX • 1-800-637-3739
(Outside US & Canada) 1-847-381-7050

masterflex.tech@avantorsciences.com • www.avantorsciences.com/masterflex

C-FLEX, NORPRENE, PHARMED, TYGON — Reg TM Saint-Gobain Performance Plastics Corp.
Trademarks bearing the ® symbol in this publication
are registered in the U.S. and in other countries.

Printed in U.S.A.



WARNING: PRODUCT USE LIMITATION

These products are not designed for, nor intended for, use in patient-connected applications; including, but not limited to, medical and dental use, and, accordingly have not been submitted for FDA approval.

Note: Use only MASTERFLEX precision tubing with MASTERFLEX pumps to ensure optimum performance. Use of other tubing may void applicable warranties.

Contents: One MASTERFLEX® I/P® Pump Head, one 20 in (50-cm) length of silicone tubing, one mounting hardware package, manual and tubing loading key.

Flat-bladed screwdriver required for mounting.

1. Single Pump Head Loading

a) Separate the end bells (the Pump Head halves). Hold the end bell containing the rotor as shown with the tubing retainer grooves pointing down.

Place tubing in the right groove and against the first two rollers. Hold tubing with thumb. Near groove, insert bottom tab of loading key between the top of the rotor and tubing. Push key in as far as possible, locking into the slot of the rotor.

b) Push down and turn key counterclockwise (CCW) completely around the rotor. The key will push the tubing uniformly into the end bell assembly.

Hold the second end of tubing. Remove the key. Position the other end bell on top and press the end bells together. Be careful not to pinch the tubing. If end bells do not snap tightly together, reload tubing. If necessary, twist key in slot on rotor shaft to adjust tubing.

c) With key in slot on rotor shaft, twist key to align tang on rotor shaft with slot in motor drive shaft. Point tubing retainer grooves up. Shift the Pump Head slightly until it snaps on the alignment pins (if present). Secure with five screws provided. Tighten with screwdriver.

1a.

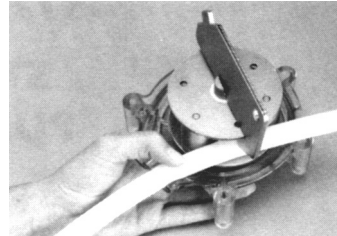

1b.

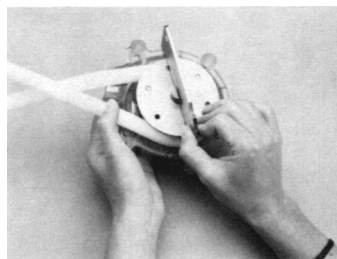

1c.

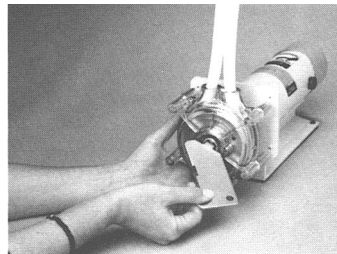

2. Multi-channel Mounting

Tubing loading key required for mounting.

Note: Order special mounting hardware for multi-channel pumping, see "4. Replacement Parts and Accessories".

a) Load the Pump Heads with tubing.

b) Install the five correct length mounting screws into the drive.

c) Slide the first Pump Head onto the mounting screws.

d) Place key in slot on rotor shaft. Twist to align tang on rotor shaft with slot in motor drive shaft.

e) Repeat for each additional Pump Head, aligning Pump Head tang with slot on previously mounted Pump Head.

f) Slide the five flat washers onto screws and secure with the five wing nuts. Tighten with fingers only.

2

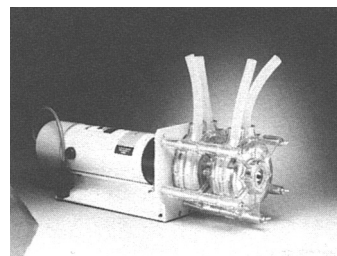

PUMP FOR LIQUIDS ORIGINAL INSTRUCTIONS

3. Maintenance and Cleaning

No lubrication is required for the I/P Standard Pump Head. Use a mild detergent solution to clean the Pump Head. Inspect the tang boot after 1,000 hours of operation and replace if necessary.

4. Replacement Parts and Accessories

A. End Bells (order two end bells for a complete head assembly).

Pump Head number	PC Order number	Pump Head number	PPS Order number
07019-00, -20	07019-78	—	—
07019-01, -21	07019-79	07019-41, -43	07019-73
07019-25, -32	07019-74	—	—
07019-26, -31	07019-75	07019-51, -53	07019-77

B. Rotor assemblies

Pump Head number	Long Shaft Order No.	Pump Head number	Short Shaft Order No.
07019-00, -25	07019-80	07019-20, -32	07019-82
07019-01, -41	07019-83	07019-21, -43	07019-85
07019-26, -51	07019-83	07019-31, -53	07019-85

C. Mounting hardware for standard pump heads

Set contains five #10-24 screws, five washers and five wing nuts.

Number of heads to be mounted	Stainless steel order number
1	07019-95
2	07019-96

D. 07019-92 Thrust washers. Pack of 10

E. 07019-90 Tubing loading key.

F. Tang Boot. 77600-02 (pkg. of 2) & 77600-03 (pkg. of 10)

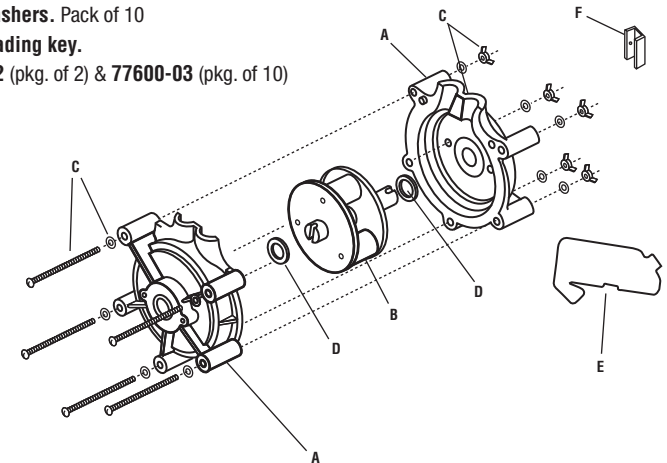

SPECIFICATIONS

Pump Head number	Housing Material	Tubing Size
07019-00, -20	PC/CRS	I/P® 73
07019-01, -21	PC/SS	I/P® 73
07019-25, -32	PC/CRS	I/P® 82
07019-26, -31	PC/SS	I/P® 82
07019-41, -43	PPS/SS	I/P® 73
07019-51, -53	PPS/SS	I/P® 82