

### EYEWASH FEATURES

- Independent eye wash & face wash integrated into one, multi-functioning safety unit.
- Aerated sprays for eyewash comfort & innovative face pads for full face cleansing
- Flip top dust caps
- Stainless Steel bowl
- ½ in. NPT female brass, chrome-plated, full flow stay-open ball valve
- Stainless steel push handle activator
- ½ in. NPT female inlet
- 4.9 gpm @ 30 psi

### SHOWER FEATURES

- 8 in. yellow plastic showerhead
- Internal 20 gpm restrictor flow control
- 1 in. NPT female brass, chrome-plated, full flow stay-open ball valve
- Powder coated yellow, aluminum triangular pull rod activator & optimal ADA extension
- 1 ¼ in. IPS galvanized steel piping stanchion & fittings
- 1 ¼ in. NPTF top or side supply
- 1 ¼ in. NPT female waste
- High visibility pull rod activates stay-open shower valve & provides hands-free operation
- DuraJade™ powder coated finish on stanchion for durability & enhanced corrosion resistance
- Elevated drain to support easier testing and to eliminate trip hazards
- Includes all components necessary to be installed in either standard height or ADA configuration
- 20 gpm @ 30 psi
- Patent Pending
- Universal Emergency Sign Included

### COMPLIANCE:

- ANSI Z358.1
- Wheelchair accessible when installed accordingly



### OPTIONS:

ADD SUFFIX TO MODEL #

- |                                |                               |
|--------------------------------|-------------------------------|
| • Anti-freeze protection valve | <input type="checkbox"/> -FPV |
| • Hand & foot operation        | <input type="checkbox"/> -HFO |
| • Hand-held spray              | <input type="checkbox"/> -HS  |
| • In-line strainer             | <input type="checkbox"/> -ILS |
| • P-trap                       | <input type="checkbox"/> -PT  |
| • Scald protection valve       | <input type="checkbox"/> -SPV |

### WARRANTY:

- 3 year limited

SEE REVERSE FOR ROUGH-IN DIMENSIONS

THIS SPACE FOR ARCHITECT/ENGINEER APPROVAL.

# SPEAKMAN®

400 ANCHOR MILL ROAD | NEW CASTLE, DE 19720  
P: 800-537-2107 | F: 800-977-2747  
WWW.SPEAKMANCOMPANY.COM

REVISION DATE: JANUARY 2014



Management Systems  
Registered to ISO 9001

# SPEAKMAN®

## Optimus™ Combination Shower and Eye And Face Wash System SE-1250

### SPECIFICATION

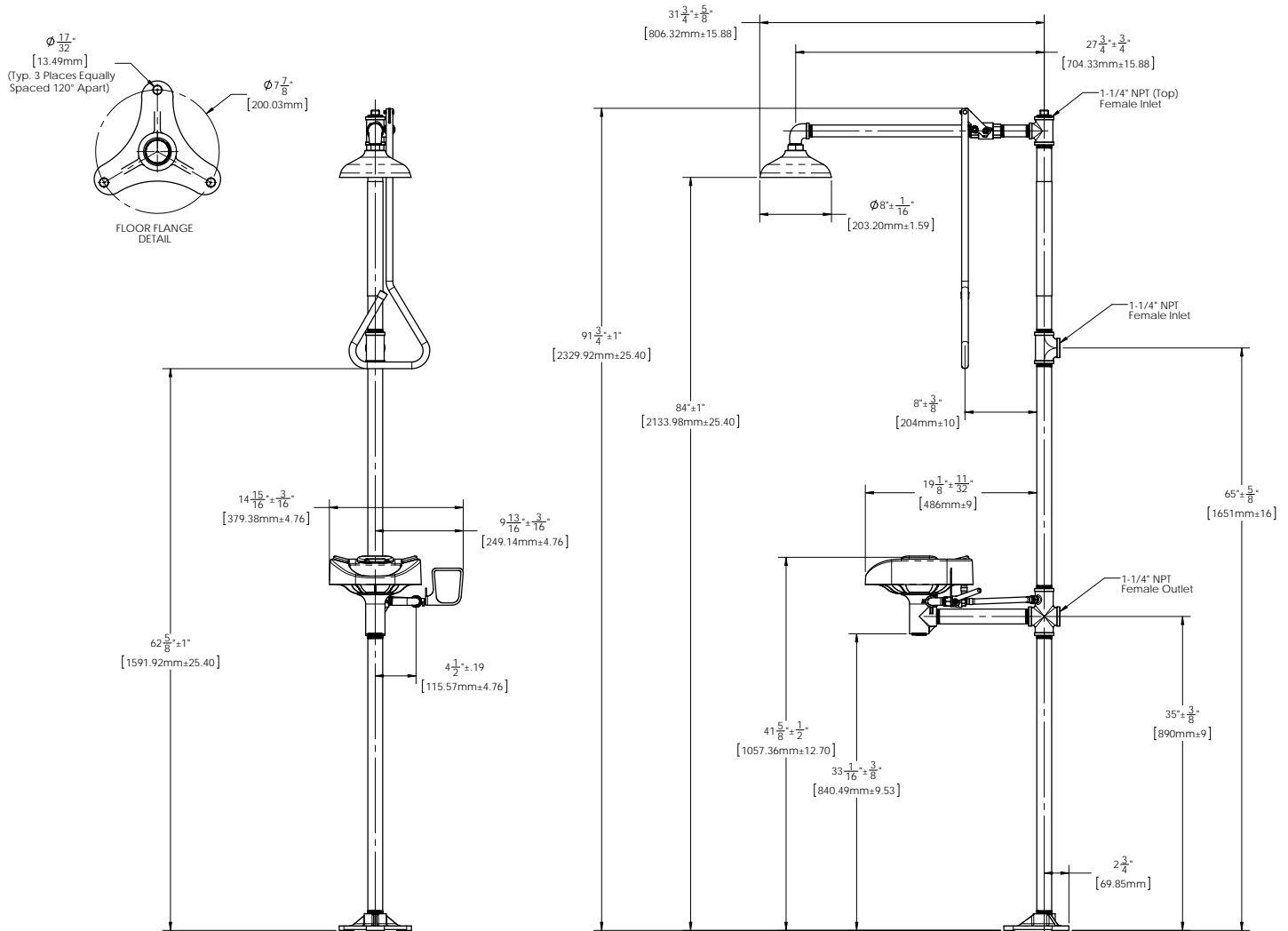

NOTE: 1. All dimensions are in inches (millimeters) unless otherwise specified and are subject to change without notice.

THIS SPACE FOR ARCHITECT/ENGINEER APPROVAL.

# SPEAKMAN®

400 ANCHOR MILL ROAD | NEW CASTLE, DE 19720  
 P: 800-537-2107 | F: 800-977-2747  
 WWW.SPEAKMANCOMPANY.COM



Management Systems  
 Registered to ISO 9001

REVISION DATE: JANUARY 2014